

ROBE

ROBIN[®] 800

LedWash Wireless DMX
CRMX[™]

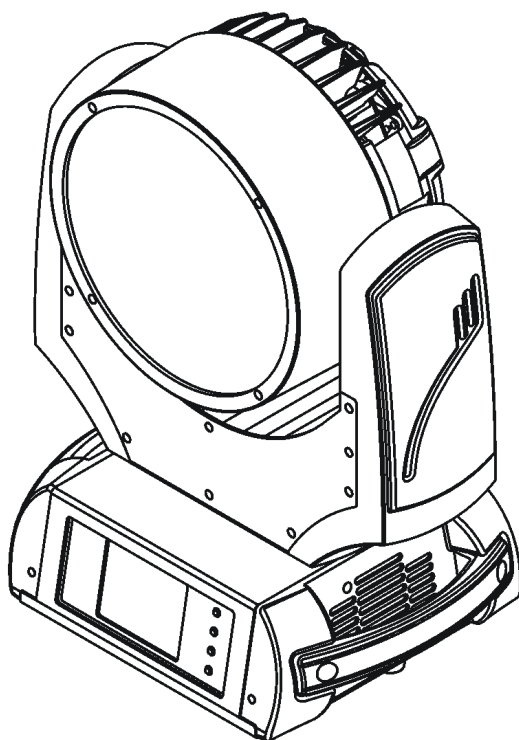

ROBE
Innovative
Technology

USER MANUAL

Version 1.4

ROBE[®] lighting s.r.o. • Czech Republic • www.robe.cz

Robin 800 LEDWash Wireless DMX

Table of contents

1. Safety instructions	3
2. Fixture exterior view	5
3. Installation	6
3.1 Connection to the mains	6
3.2 Installing the top hat	7
3.3 Installing the front clear transparent cover	7
3.4 Rigging the fixture	9
3.5 DMX-512 connection.....	11
3.6 Ethernet connection	12
4. Wireless DMX operation	14
5. Control menu map	15
6. Robin 800 LEDWash - DMX chart	18
6.1 Virtual colour wheel - colour mixing chart.....	22
6.2 LED zone order	26
7. Control menu	27
7.1 Tab "Address"	28
7.2 Tab "Information"	29
7.3 Tab "Personality"	30
7.4 Tab "Manual Control"	32
7.5 Tab "Stand-alone"	32
7.6 Tab "Service"	33
8. RDM	35
9. Error and information messages	35
10. Technical Specifications	36
11. Maintenance and cleaning	38
11.1 Replacing fuse.....	39
12. ChangeLog	39
13. Photometric diagrams	40

**FOR YOUR OWN SAFETY, PLEASE READ THIS USER MANUAL CAREFULLY
BEFORE POWERING OR INSTALLING YOUR ROBIN 800 LEDWASH !**

Save it for future reference.

This device has left our premises in absolutely perfect condition. In order to maintain this condition and to ensure a safe operation, it is absolutely necessary for the user to follow the safety instructions and warning notes written in this manual.

The manufacturer will not accept liability for any resulting damages caused by the non-observance of this manual or any unauthorized modification to the device.

Please consider that damages caused by manual modifications to the device are not subject to warranty.

The Robin 800 LEDWash was designed for indoor use and it is intended for professional application only. It is not for household use.

1. Safety instructions

DANGEROUS VOLTAGE CONSTITUTING A RISK OF ELECTRIC SHOCK IS PRESENT WITHIN THIS UNIT!

Make sure that the available voltage is not higher than stated on the rear panel of the fixture. This fixture should be operated only from the type of power source indicated on the marking label. If you are not sure of the type of power supplied, consult your authorized distributor or local power company.

Always disconnect the fixture from AC power before cleaning, removing or installing the fuses, or any part.

The power plug has to be accessible after installing the fixture. Do not overload wall outlets and extension cords as this can result in fire or electric shock.

Do not allow anything to rest on the power cord. Do not locate this fixture where the cord may be damaged by persons walking on it.

Make sure that the power cord is never crimped or damaged by sharp edges. Check the fixture and the power cord from time to time.

Refer servicing to qualified service personnel.

This fixture falls under protection class I. Therefore this fixture has to be connected to a mains socket outlet with a protective earthing connection.

Do not connect this fixture to a dimmer pack.

**LED light emission. Risk of eye injury.
Do not look straight at the fixture's LED source during operation. The intense light beam may damage your eyes. Sensitive persons may suffer an epileptic shock.
Provide advance notice that strobe lighting is in use.**

Do not view the light output with optical instruments or any device that may concentrate the beam

If the fixture has been exposed to drastic temperature fluctuation (e.g. after transportation), do not switch it on immediately. The arising condensation water might damage your device. Leave the device switched off until it has reached room temperature.

Do not shake the fixture. Avoid brute force when installing or operating the fixture.

This fixture was designed for indoor use only, do not expose this unit to rain or use near water.

When choosing the installation spot, please make sure that the fixture is not exposed to extreme heat, moisture or dust.

Air vents and slots in the fixture's head and base are provided for ventilation, to ensure reliable operation of the device and to protect it from overheating.

Do not block the LEDs array with any object when the fixture is under operation.

The openings should never be covered with cloth or other materials, and never must be blocked.

This fixture should not be placed in a built-in installation unless proper ventilation is provided.

Only operate the fixture after having checked that the housing is firmly closed and all screws are tightly fastened.

Always use a secondary safety cable when mounting this fixture.

Make sure that the area below the installation place is blocked when rigging, derigging or servicing the fixture.

Do not block the front objective LEDs with any object when the fixture is under operation.

The fixture becomes very hot during operation. Allow the fixture to cool approximately 20 minutes prior to manipulate with it.

Operate the fixture only after having familiarized with its functions. Do not permit operation by persons not qualified for operating the fixture. Most damages are the result of unprofessional operation!

Please use the original packaging if the fixture is to be transported.

Please consider that unauthorized modifications on the fixture are forbidden due to safety reasons!

If this device will be operated in any way different to the one described in this manual, the product may suffer damages and the guarantee becomes void. Furthermore, any other operation may lead to dangers like short-circuit, burns, electric shock, crash etc.

CAUTION!

To avoid damage of the internal parts of the fixture head, never let the sunlight or othert light source lights directly to the front lens, even when the fixture is not working !

2. Fixture exterior view

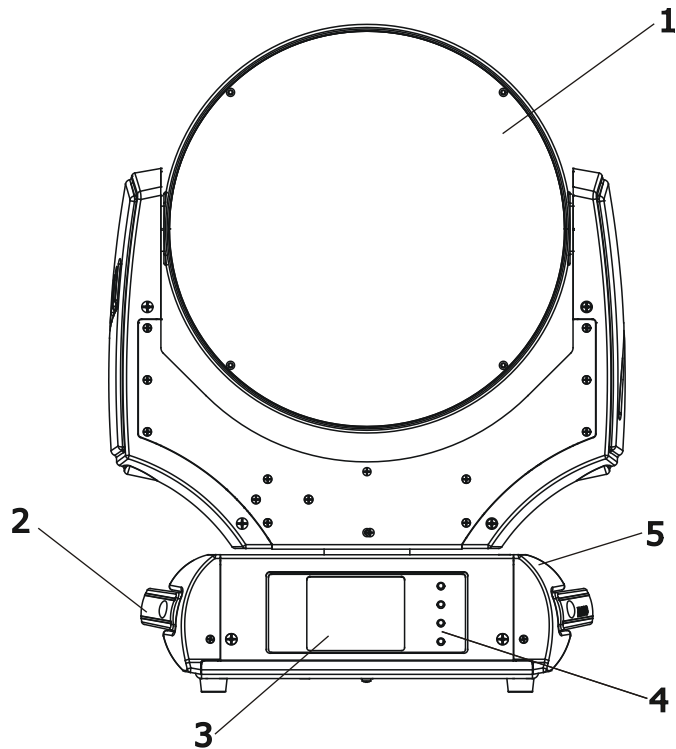

- 1 - Lens array
- 2 - Carrying handle
- 3 - QVGA touch screen
- 4 - Control buttons
- 5 - Base

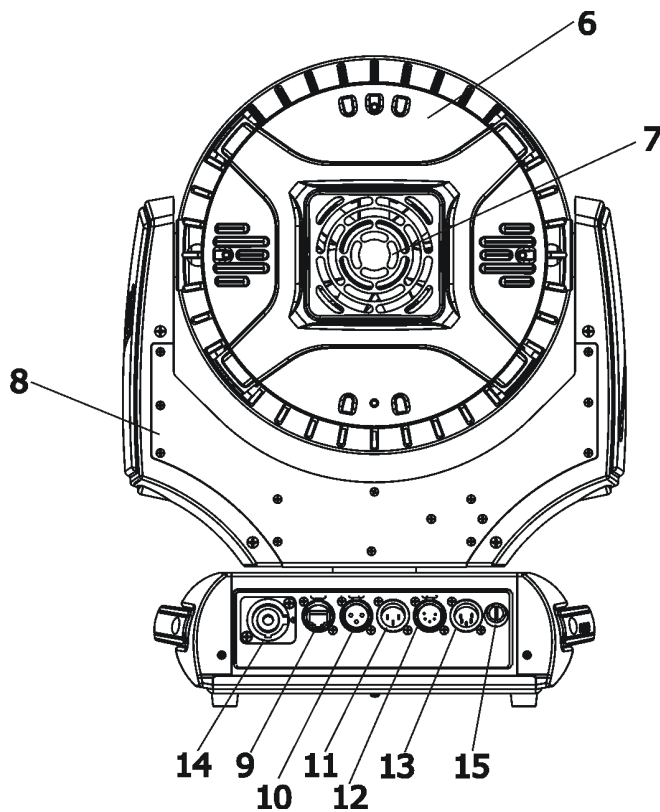

- 6 - Head cover
- 7 - Fan
- 8 - Yoke
- 9 - Ethernet input
- 10 - 3-pin DMX OUT
- 11 - 3-pin DMX IN
- 12 - 5-pin DMX OUT
- 13 - 5-pin DMX IN
- 14 - Power con
- 15 - Fuse holder

The ENTER/DISPLAY ON button also serves for switching the display on when the fixture is disconnected from the mains.

3. Installation



Fixtures must be installed by a Qualified electrician in accordance with all national and local electrical and construction codes and regulation.

3.1 Connection to the mains

For protection from electric shock, the fixture must be earthed!

The Robin 800 LEDWash is equipped with auto-switching power supply that automatically adjusts to any 50/60Hz AC power source from 100-240 Volts.

Install a suitable plug on the power cord, note that the cores in the power cord are coloured according to the following table. The earth has to be connected!

If you have any doubts about proper installation, consult a qualified electrician.

Core (EU)	Core (US)	Connection	Plug Terminal Marking
Brown	Black	Live	L
Light blue	White	Neutral	N
Yellow/Green	Green	Earth	

3.2 Installing the top hat

Disconnect the fixture from mains before top hat installation

1. Go to the fixture menu and set reduced tilt movement (Personality --> Pan/Tilt Setting--> Tilt Movement Range --> reduced).
2. Place the top hat on the head, press locks (1) and turn the top hat counter-clockwise until it snap into slots in the flange.

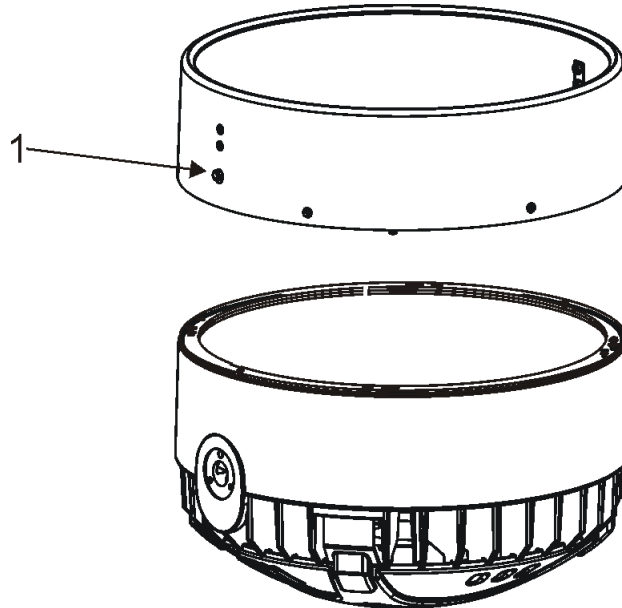

3.3 Installing the front clear transparent cover

Uninstallation of the beam shaper

1. Disconnect fixture from the mains.
2. Press and hold both locks (1) and turn the beam shaper module (2) clockwise until three pins (3) are loosen from slots (4).
3. Remove the beam shaper module (2) from the fixture head.
4. Connect fixture to the mains.

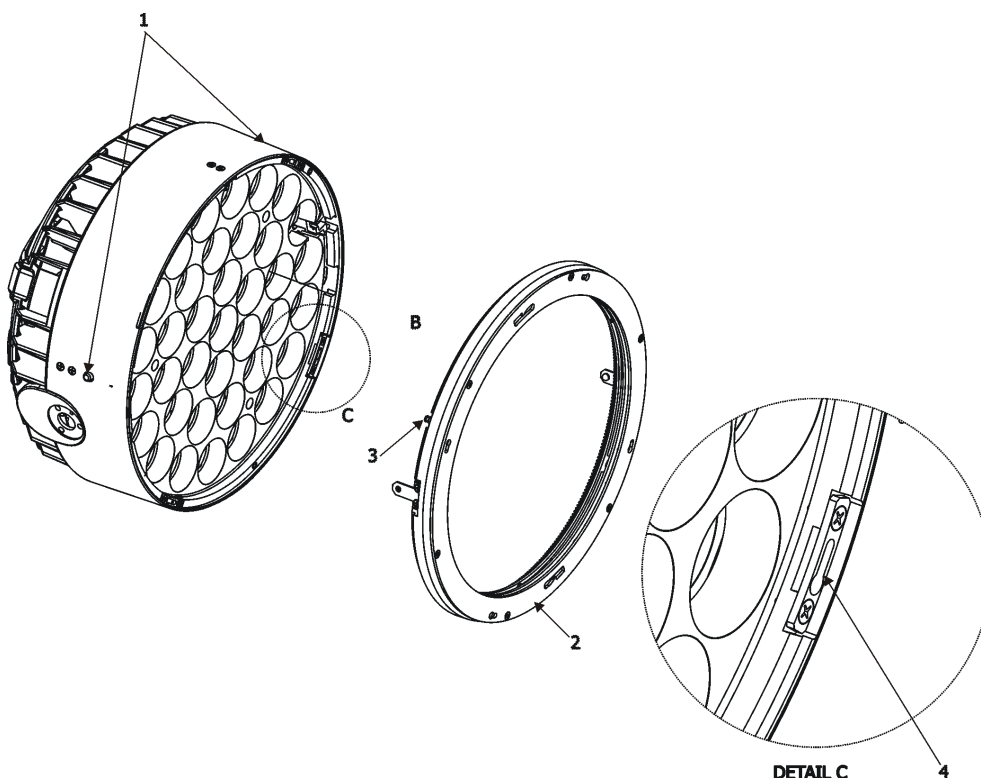

Installation of the front clear transparent cover

5. Place the front transparent cover (5) on the head in this way that adjusting pegs (6) will point to slots in the head (7).
6. Turn the front transparent cover (5) anticlockwise until three pins (3) snap into slots (4).
7. Connect fixture to the mains.

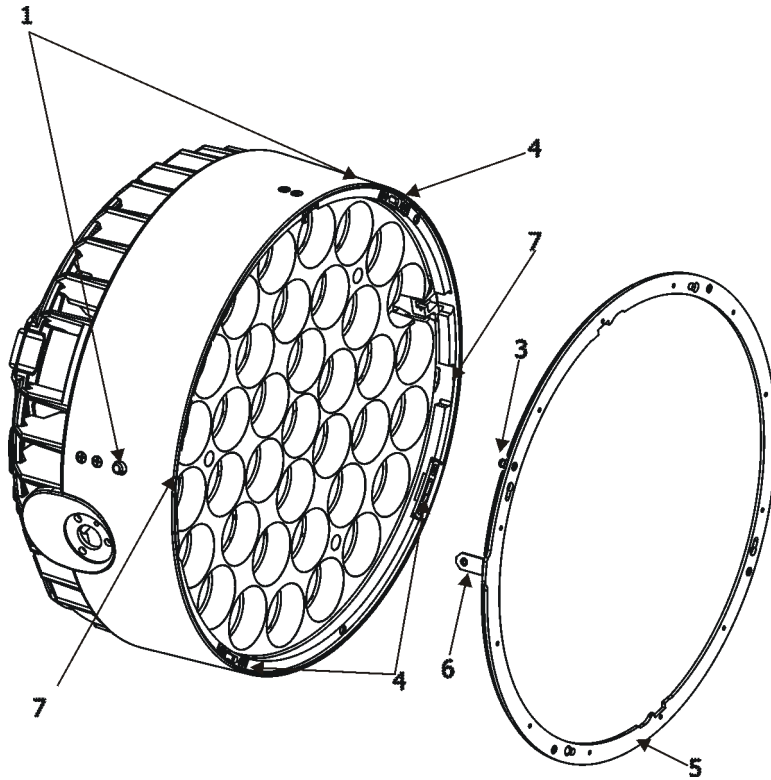

Note: Beam shaper works best at min. zoom.

3.4 Rigging the fixture

The installation of the fixture has to be built and constructed in a way that it can hold 10 times the weight for 1 hour without any harming deformation.

The installation must always be secured with a secondary safety attachment, e.g. an appropriate catch net. This secondary safety attachment must be constructed in a way that no part of the installation can fall down if the main attachment fails.

When rigging, derigging or servicing the fixture staying in the area below the installation place, on bridges, under high working places and other endangered areas is forbidden.

The operator has to make sure that safety-relating and machine-technical installations are approved by an expert before taking into operation for the first time and after changes before taking into operation another time.

The operator has to make sure that safety-relating and machine-technical installations are approved by an expert after every four year in the course of an acceptance test.

The operator has to make sure that safety-relating and machine-technical installations are approved by a skilled person once a year.

The fixture should be installed outside areas where persons may walk by or be seated.

IMPORTANT! OVERHEAD RIGGING REQUIRES EXTENSIVE EXPERIENCE, including (but not limited to) calculating working load limits, installation material being used, and periodic safety inspection of all installation material and the projector. If you lack these qualifications, do not attempt the installation yourself, but instead use a professional structural rigger. Improper installation can result in bodily injury or damage to property. The fixture has to be installed out of the reach of people.

If the fixture shall be lowered from the ceiling or high joists, professional trussing systems have to be used. The fixture must never be fixed swinging freely in the room.

Caution: Fixture may cause severe injuries when crashing down! If you have doubts concerning the safety of a possible installation, do not install the moving head!

Before rigging make sure that the installation area can hold a minimum point load of 10 times the fixture's weight.

When installing the device, make sure there is no highly inflammable material (decoration articles, etc.) in a distance of min. 0.5 m.

CAUTION!
Use an appropriate clamp to rig the fixture on the truss.
Follow the instructions mentioned at the bottom of the base.
Make sure that the device is fixed properly! Ensure that the structure (truss) to which you are attaching the fixtures is secure.

The fixture can be placed directly on the stage floor or rigged on a truss without altering its operation characteristics .

For securing a fixture to the truss install a safety wire that can hold at least 10 times the weight of the fixture. Use only safety wire with screw-on carabine. Pull the safety wire through the carrying handles and around the truss as shown on the pictures below.

Note: If the safety wire is too long, whip it several times around the trusses in order to attach the fixture tight. In case of an accident, the way of the falling fixture will be short.

Rigging via two Omega holders

Securing the fixture via one safety wire

Securing the fixture via two safety wires

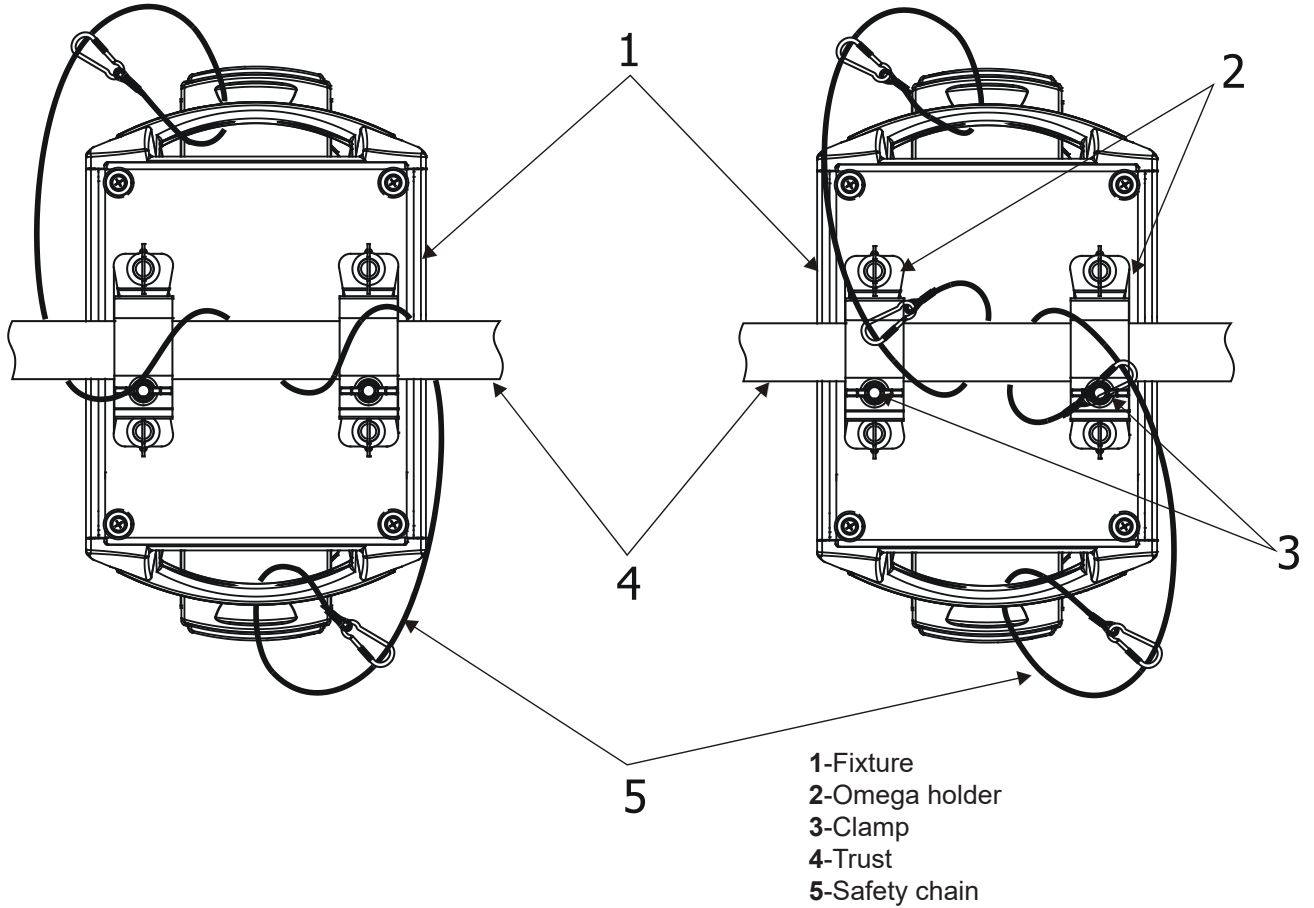

The fixture can be also rigged by means of the mounting adapter (option) for one Omega holder..

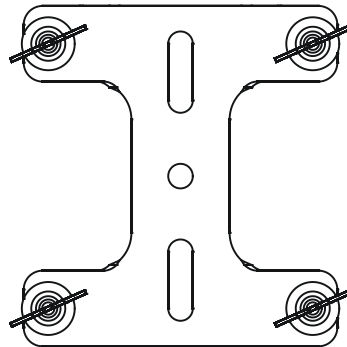

In this case the fixture can hang on the truss in horizontal position only, not sideways .

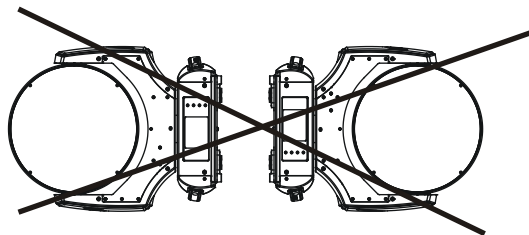
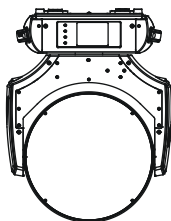

3.5 DMX-512 connection

The fixture is equipped with both 3-pin and 5-pin XLR sockets for DMX input and output. The sockets are wired in parallel.

Only use a shielded twisted-pair cable designed for RS-485 and 3-pin or 5-pin XLR-plugs and connectors in order to connect the controller with the fixture or one fixture with another.

DMX - output

XLR mounting-sockets (rear view):

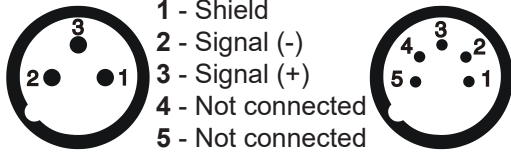

DMX-input

XLR mounting-plugs (rear view):

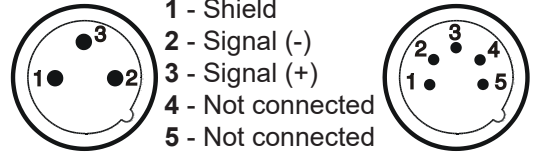

If you are using the standard DMX controllers, you can connect the DMX output of the controller directly with the DMX input of the first fixture in the DMX-chain. If you wish to connect DMX-controllers with other XLR-outputs, you need to use adapter-cables.

Building a serial DMX-chain:

Connect the DMX-output of the first fixture in the DMX-chain with the DMX-input of the next fixture. Always connect one output with the input of the next fixture until all fixtures are connected.

Caution: At the last fixture, the DMX-cable has to be terminated with a terminator. Solder a 120 Ω resistor between Signal (-) and Signal (+) into a 3-pin XLR-plug and plug it in the DMX-output of the last fixture.

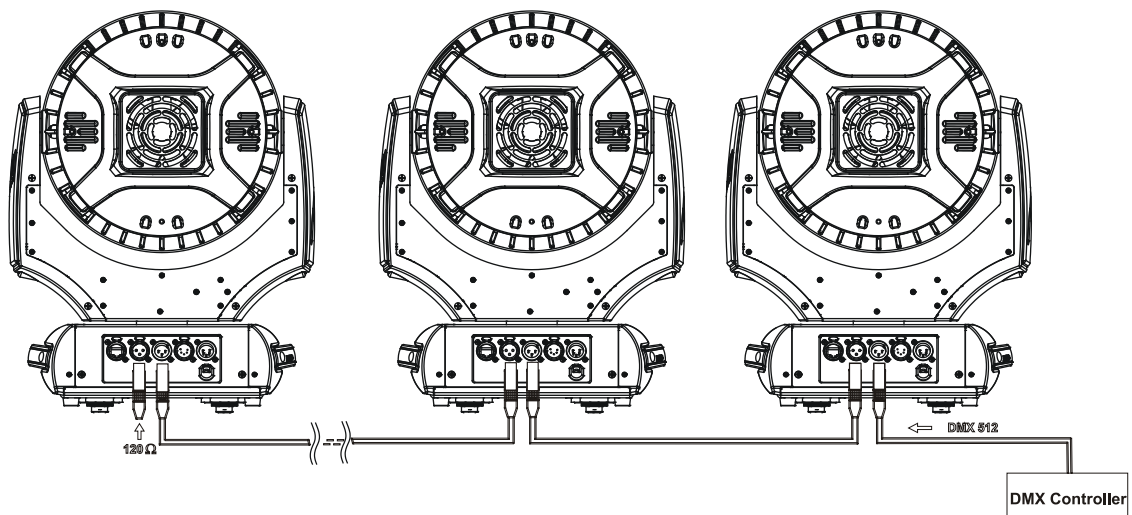

3.6 Ethernet connection

The fixtures on a data link are connected to the Ethernet with ArtNet communication protocol. The control software running on your PC (or light console) has to support Art-Net protocol.

Art-Net communication protocol is a 10 Base T Ethernet protocol based on the TCP/IP. Its purpose is to allow transfer of large amounts of DMX 512 data over a wide area using standard network technology.

IP address is the Internet protocol address. The IP uniquely identifies any node (fixture) on a network.

The Universe is a single DMX 512 frame of 512 channels.

The Robin 300E Wash is equipped with 8-pin RJ-45 socket for Ethernet input. Use a network cable category 5 (with four "twisted" wire pairs) and standard RJ-45 plugs in order to connect the fixture to the network.

RJ-45 socket (front view):

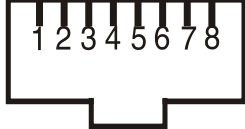

- 1- TD+
- 2- TD-
- 3- RX+
- 4- Not connected
- 5- Not connected
- 6- RX-
- 7- Not connected
- 8- Not connected

RJ-45 plug (front view):

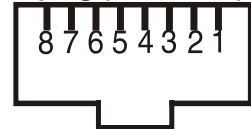

Patch cables that connect fixtures to the hubs or LAN sockets are wired 1:1, that is, pins with the same numbers are connected together:



If only the fixture and the computer are to be interconnected, no hubs or other active components are needed. A cross-cable has to be used:



If the fixture is connected with active Ethernet socket (e.g. switch) the network icon  will appear at the bottom right corner of the screen:

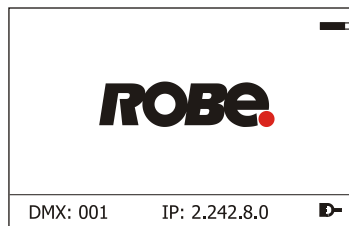

Direct Ethernet operation

Connect the Ethernet inputs of all fixtures with the Ethernet network.

Option "Artnet (gMal or gMA2)" has to be selected from "Ethernet Mode" menu on the fixture.

Set IP address (002.xxx.xxx.xxx / 010.xxx.xxx.xxx) and the Universe.

(DMX address=46)
IP address=002.168.002.004
Universe=1

(DMX address=23)
IP address=002.168.002.003
Universe=1

(DMX address=1)
IP address=002.168.002.002
Universe=1

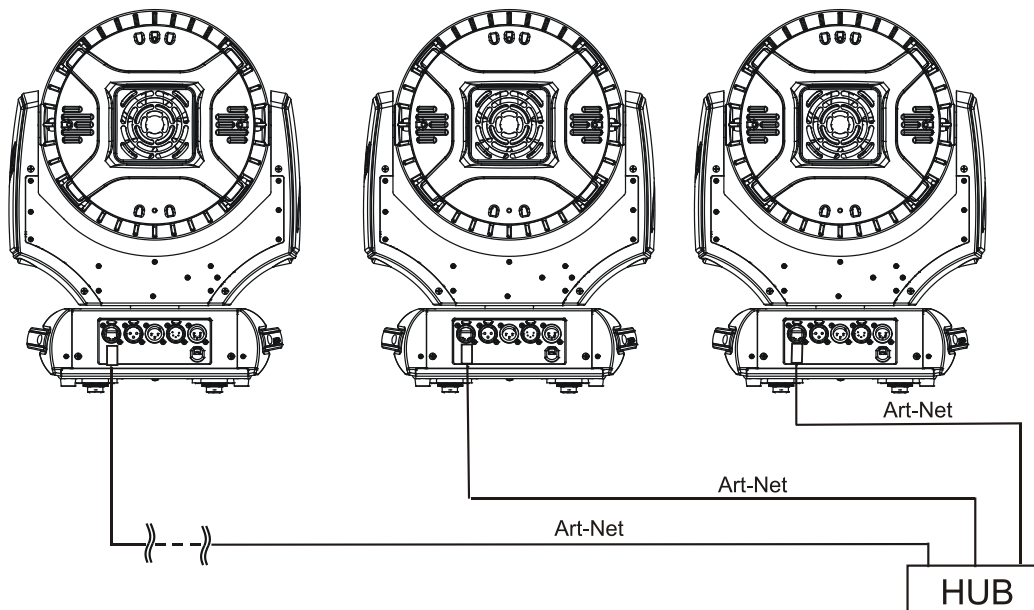

An advised PC setting: IP address: 002.xxx.xxx.xxx / 010.xxx.xxx.xxx (Different from fixture IP addresses)
NET mask: 255.0.0.0

Ethernet / DMX operation

Options "Art2DMX" has to be selected from the "Ethernet Mode" menu on the first fixture (connected to the Ethernet) in the fixture chain, next fixtures have standard DMX setting.

Connect the Ethernet-input of the first fixture in the data chain with the network. Connect the DMX output of this fixture with the input of the next fixture until all fixtures are connected to the DMX chain.

Caution: At the last fixture, the DMX chain has to be terminated with a terminator. Solder a 120 Ω resistor between Signal (-) and Signal (+) into a XLR-plug and connect it in the DMX-output of the last fixture.

Example:

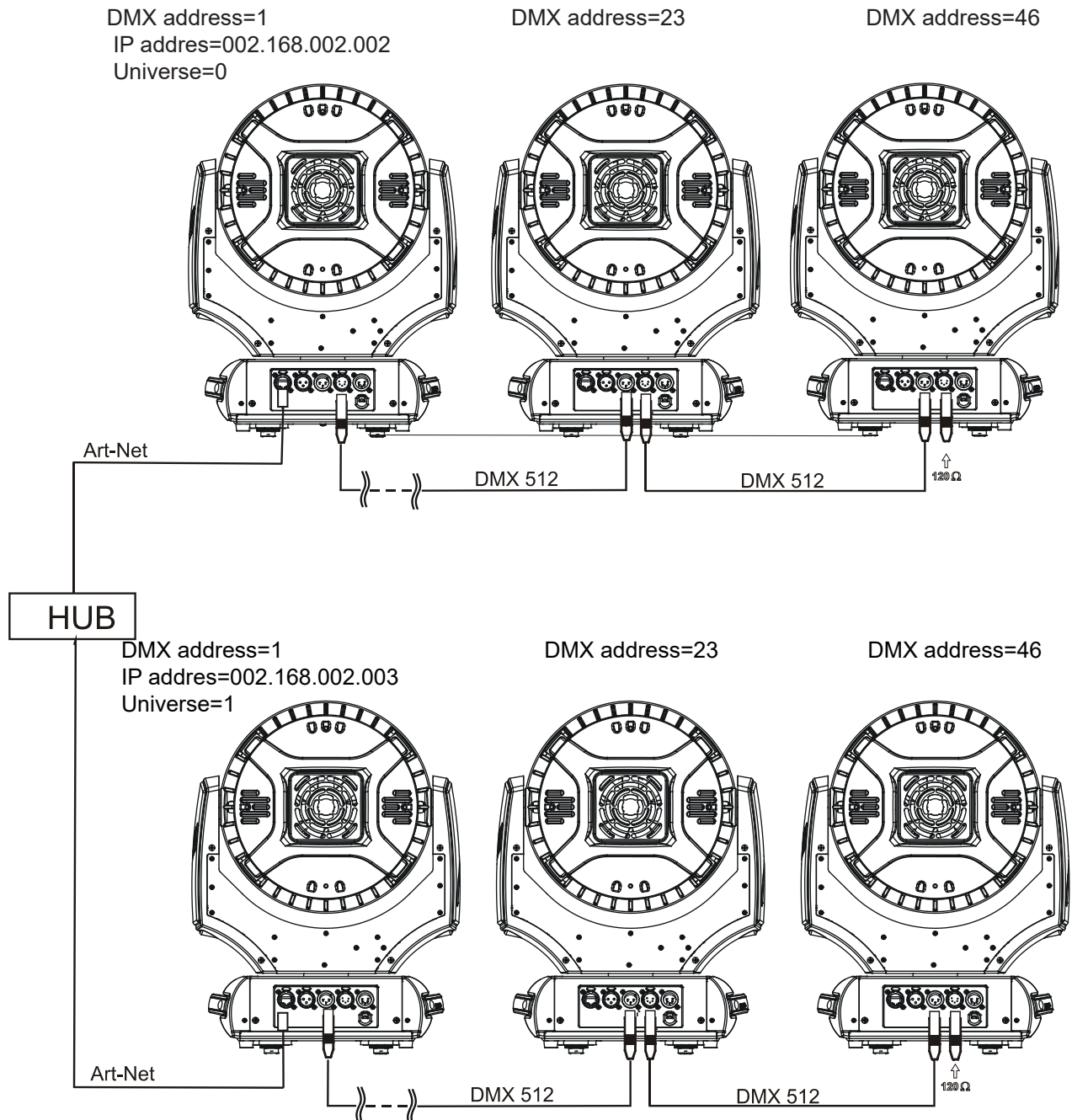

4. Wireless DMX operation

The Robin 800 LEDWash is equipped with the Lumen Radio CRMX module and antenna for receiving DMX signal. CRMX module operates on the 2.4 GHz band.

The item " Wireless " from the menu "DMX Input" allows you to activate receiving of wireless DMX (Personality--> DMX Input -->Wireless.). First two options from the "DMX Input" menu are stated in DMX chart as well (channel Power/Special functions , range of 10-19 DMX). If DMX input option is changed by DMX command, the change is permanently written into fixture's memory.

DMX range of 10-19 switching fixture to the wired/wireless operation is active only during first 10 seconds after switching the fixture on.

After switching the fixture on, the fixture checks both modes of receiving DMX in the following order:

1. For the first five seconds, the fixture receives DMX signal from the wired input. If the Power/Special functions channel is set at some DMX input option, the fixture will receive DMX value according to this option. If DMX input option is set to the wired input , this option is saved and checking procedure is finished. If DMX input option is not set, the fixture continues next 5 seconds in scanning wireless DMX signal-see point 2.

2. For the next 5 seconds the fixture receives wireless DMX signal and again detects if the Power/Special functions channel is set at some DMX input option, if not, the fixture will take option which is set in the fixture menu "DMX Input".

To link the fixture with DMX transmitter.

The fixture can be only linked with the transmitter by running the link procedure at DMX transmitter . After linking , the level of DMX signal (0-100 %) is displayed in the menu item "Wireless State" (Information -->Wireless State).

To unlink the fixture from DMX transmitter.

The fixture can be unlinked from receiver via the menu item " Unlink Wireless Adapter" (Information--> Wireless State --> Unlink Wireless Adapter.).

Note: If the option "Wireless In/XLR Out" is selected (Personality--> DMX Input -->Wireless In/XLR Out), the fixture receives wireless DMX and sends the signal to its wired DMX output. The fixture behaves as " Wireless/Wired" adapter.

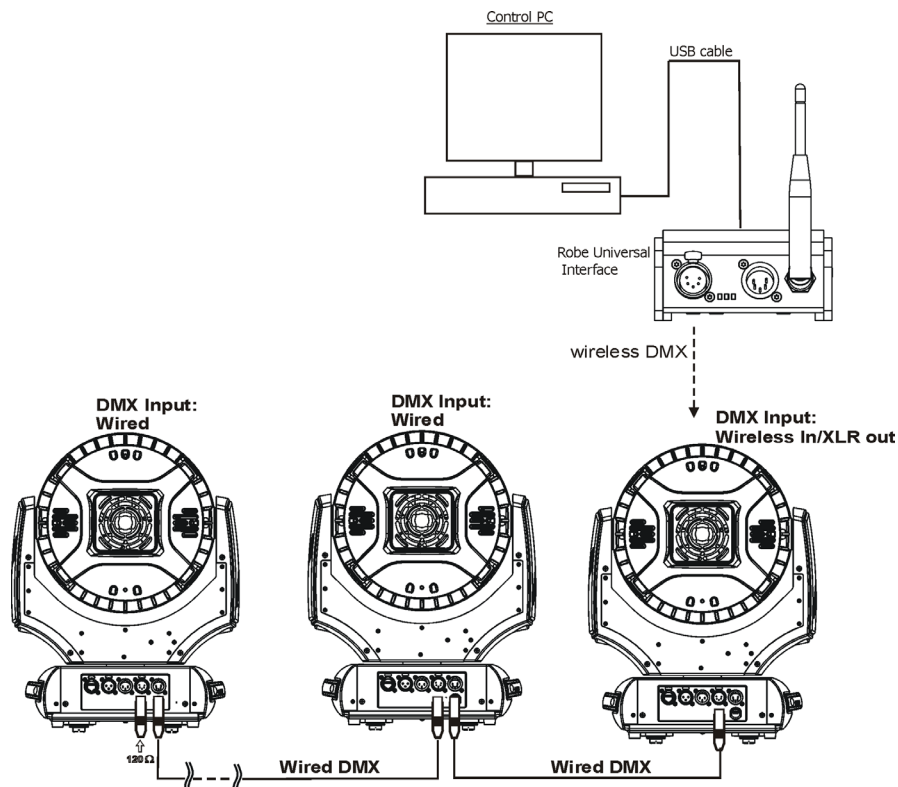

Example of using



5. Control menu map

Default settings=**Bold print**

Tab	Level 1	Level 2	Level 3	Level 4	Level 5	Level 6	
Addressing	Settings	DMX Address	001-512				
		Ethernet Settings	Ethernet Mode	Disable			
				ArtNet			
				gMA1			
				gMA2			
				Art2DMX			
				IP Address/NetMask	Default IP Address		
					Custom IP Address		
					Net Mask		
				ArtNet Universe	0-255		
				MANet settings	MANet I/IIUniverse	1-256	
					MANet Session ID	1-32	
	Information	Fixture Times	Power On Time	Total Hours			
			Resetable Hours				
	Fixture Temperatures	LEDs Temperature	Current				
			Maximum NonRes.				
			Maximum Res.				
		AmbientTemperature	Current				
			Maximum NonRes.				
			Maximum Res.				
		Base Temperature	Current				
			Maximum NonRes.				
			Maximum Res.				
		DMX Values	Pan				
			:				
		Dimmer Fine					
	Wireless State	Signal Quality					
		Unlink Wireless Adapter					
	Software Versions	Display System					
		Module M					
		Module L					
	Product IDs	Mac Address					
		RDM UID					
		RDM Label					
	View Logs	Fixture Errors					
		Fixture Status	Power On				
			Power Off				
		Fixture Position					
		Fixture Temperatures	LEDs Temperature				
			Ambient Temperature				
			Base Temperature				
Personality	User Mode	User A Settings					
		User B Settings					
		User C Settings					
	DMX Presets	Mode 1					
		:					
		Mode 6					
		View Selected Preset					
	DMX Input	Wired					

Tab	Level 1	Level 2	Level 3	Level 4	Level 5	Level 6
		Wireless				
		Wireless In/XLR Out				
	Pan/Tilt Settings	Pan Reverse	Off, On			
		Tilt Reverse	Off, On			
		Pan/Tilt Feedback	Off, On			
		Pan/Tilt mode	Time			
			Speed			
		Tilt Movement range	Stand.			
			Reduc.			
	Microphone Sensitivity	1-10-20				
	Blackout Settings	Blackout During M.C.	Off, On			
		Blackout while:	Pan/Tilt moving	Off, On		
	Colour Calibration Mode	Off, On				
	Zoom Mode	Beam Zoom				
		Wash Zoom				
	Init Effect Positions	Pan	0-255			
		:				
		Dimmer Fine	0-255			
	Screen Settings	Display Intensity	1-10			
		Screen Saver Delay	Off-10min.			
		Touchscreen Lock	Off-10min.			
		Recalibrate Touchscreen				
		Display Orientation	Normal			
			Inverted			
			Auto			
	Temperature Unit	°C, °F				
	Fan Mode	Auto				
		High				
	Theatre mode	On, Off				
	Date & Time Settings					
	Default Settings					
Manual Control	Reset Functions	Total System Reset				
		Pan/Tilt reset				
		Zoom Reset.				
	Preset Effect Control	Pan	Position 1-Position 5			
		:				
		Dimmer	Position 1- Position 5			
	Manual Effect Control	Pan	0-255			
		:				
		Dimmer Fine	0-255			
Stand -Alone	Test Sequences	Dynamic Mode				
		Static Mode	Pan	0-255		
			Tilt	0-255		
			Zoom	0-255		
	MusicTrigger	Off, On				
	Preset Playback	None				
		Test				
		:				
		Prog. 3				

Tab	Level 1	Level 2	Level 3	Level 4	Level 5	Level 6
	Play Program	Play Program 1				
		Play Program 2				
		Play Program 3				
	Edit Program	Edit Program 1	Start Step	1-100		
			End Step	1-100		
			Edit Program Steps	Step 1	Pan (0-255)	
				:	:	
				:	Dimmer Fine (0-255)	
				:	Step Time (0-25.5s)	
				Step 100	Pan (0-255)	
					:	
					Dimmer Fine (0-255)	
					Fade Time (0-25.5s)	
Service	Adjust DMX Values	Pan	0-255			
		:				
		Dimmer Fine	0-255			
	Calibrations	Calibrate Effects	Pan	0-255		
			Tilt	0-255		
		Calibrate colours	Red	0-255		
			Green	0-255		
			Blue	0-255		
			White	0-255		
		Load Default Calibrations				
	Update Software					

6. Robin 800 LEDWash - DMX chart

Version 1.1

Mode/Channel						Value	Function	Type of control
1	2	3	4	5	6			
1	1	1	1	1	1	0-255	Pan (8 bit) Pan movement by 450°	proportional
2	2	2	2	2	2	0-255	Pan Fine (16 bit) Fine control of pan movement	proportional
3	3	3	3	3	3	0-255	Tilt (8bit) Tilt movement by 300°	proportional
4	4	4	4	4	4	0-255	Tilt fine (16 bit) Fine control of tilt movement	proportional
5	5	5	5	5	5	0	Pan/Tilt speed, Pan/Tilt time Max. speed -standard mode (0=default)	step
						1 - 255	<u>P./T. speed</u>-set Speed Mode in menu: P./T. Mode Speed from max. to min.	proportional
						1 - 255	<u>P./T. time</u> - set Time Mode in menu: Pan/Tilt Mode Time from 0.1 s to 25.5 s.	proportional
6	6	6	6	6	6	0 - 9	Special functions Reserved <i>To activate following functions , stop in DMX value for at least 3sec. and shutter must be closed at least 3sec. (Shutter channel 36/20/15/10/10/35 must be at range of 0-31DMX). Corresponding menu items are temporarily overridden except DMX Input.</i>	
						10 - 14	DMX input: Wired DMX *	step
						15 - 19	DMX input: Wireless DMX* * function is active only 10 seconds after switching the fixture on	step
						20 - 29	Reserved	
						30 - 39	RGBW colour mixing mode	step
						40 - 49	CMY colour mixing mode	step
						50-59	Pan/Tilt speed mode	step
						60-69	Pan/Tilt time mode	step
						70 - 79	Blackout while pan/tilt moving	step
						80 - 89	Disabled blackout while pan/tilt moving	step
						90 - 99	Theatre mode On	step
						100-109	Theatre mode Off	step
						110-114	Zoom mode: Wash	step
						115-119	Zoom mode:Beam	step
						120-139	Reserved <i>To activate following reset function, stop in DMX value for at least 3 sec.</i>	
						140 - 149	Pan/Tilt reset	step
						150 - 179	Reserved	
180 - 189	Zoom/beam shaper reset	step						
190 - 199	Reserved							
200 - 209	Total reset	step						
210 - 239	Reserved							
240	Disable "Silent mode" of fans <i>To activate "Silent ", stop in range of 241-255 at least 3 sec.</i>	step						
241 - 255	"Silent mode of fans":fans noise from min. to max.	proportional						
-	7	7	-	-	-	0-255	Red/Cyan (8 bit) - all zones Red (cyan)LEDs saturation control (0-100%)	proportional
-	8	-	-	-	-	0-255	Red/Cyan fine(16 bit) - all zones Fine red (cyan) LEDs saturation control	proportional
-	9	8	-	-	-	0-255	Green/Magenta (8 bit) - all zones Green (magenta) LEDs saturation control (0-100%)	proportional
-	10	-	-	-	-	0-255	Green/Magenta fine (16 bit) - all zones Fine green (magenta) LEDs saturation control	proportional

Mode/Channel						Value	Function	Type of control
1	2	3	4	5	6			
-	11	9	-	-	-	0-255	Blue/Yellow (8 bit) - all zones Blue (yellow) LEDs saturation control (0-100%)	proportional
-	12	-	-	-	-	0-255	Blue/Yellow fine (16 bit) - all zones Fine blue(yellow) LEDs saturation control	proportional
-	13	10	-	-	-	0-255	White (8 bit) - all zones <i>If RGBW mode is selected:</i> White colour saturation control coarse (0-100%) <i>If CMY mode is selected:</i> No function	proportional
-	14	-	-	-	-	0-255	White fine (16 bit) - all zones Fine white LEDs saturation control (RGBW mode)	proportional
7	-	-	-	15	7	0-255	Red/Cyan (8 bit) - zone 1 Red (cyan) LEDs saturation control (0-100%)	proportional
8	-	-	-	16	8	0-255	Red/cyan fine (16 bit) - zone 1 Fine red (cyan) LEDs saturation control	proportional
9	-	-	-	17	9	0-255	Green/magenta (8 bit) - zone 1 Green (magenta)LEDs saturation control (0-100%)	proportional
10	-	-	-	18	10	0-255	Green/magenta fine (16 bit) - zone 1 Fine green (magenta)LEDs saturation control	proportional
11	-	-	-	19	11	0-255	Blue/Yellow (8 bit) zone 1 Blue (yellow) LEDs saturation control (0-100%)	proportional
12	-	-	-	20	12	0-255	Blue/Yellow (16 bit) zone 1 Fine blue (yellow) LEDs saturation control)	proportional
13	-	-	-	21	13	0-255	White (8 bit) - zone 1 <i>If RGBW mode is selected:</i> White colour saturation control coarse (0-100%) <i>If CMY mode is selected:</i> No function	proportional
14	-	-	-	22	14	0-255	White (16 bit) - zone 1 Fine white LEDs saturation control (RGBW mode)	proportional
15	-	-	-	23	15	0-255	Red/Cyan (8bit) - zone 2 Red (cyan) LEDs saturation control (0-100%)	proportional
16	-	-	-	24	16	0-255	Red/Cyan fine (16 bit) - zone 2 Fine red (cyan) LEDs saturation control	proportional
17	-	-	-	25	17	0-255	Green/Magenta (8 bit) - zone 2 Green (magenta) LEDs saturation control (0-100%)	proportional
18	-	-	-	26	18	0-255	Green/Magenta fine (16 bit) - zone 2 Fine green (magenta) LEDs saturation control	proportional
19	-	-	-	27	19	0-255	Blue/Yellow (8 bit) - zone 2 Blue (Yellow) LEDs saturation control (0-100%)	proportional
20	-	-	-	28	20	0-255	Blue/Yellow fine (16 bit) - zone 2 Fine blue (yellow) LEDs saturation control	proportional
21	-	-	-	29	21	0-255	White (8 bit) - zone 2 <i>If RGBW mode is selected:</i> White colour saturation control coarse (0-100%) <i>If CMY mode is selected:</i> No function	proportional
22	-	-	-	30	22	0-255	White (16 bit) - zone 2 Fine white LEDs saturation control (RGBW mode)	proportional
23	-	-	-	31	23	0-255	Red/Cyan (8 bit) - zone 3 Red (cyan) LEDs saturation control (0-100%)	proportional
24	-	-	-	32	24	0-255	Red/Cyan fine (16 bit) - zone 3 Fine red (cyan) LEDs saturation control	proportional

Mode/Channel						Value	Function	Type of control
1	2	3	4	5	6			
25	-	-	-	33	25	0-255	Green/Magenta (8 bit) - zone 3 Green (magenta) LEDs saturation control (0-100%)	proportional
26	-	-	-	34	26	0-255	Green/Magenta fine (16 bit) - zone 3 Fine green (magenta) LEDs saturation control	proportional
27	-	-	-	35	27	0-255	Blue/Yellow (8 bit) zone 3 Blue (yellow) LEDs saturation control (0-100%)	proportional
28	-	-	-	36	28	0-255	Blue/Yellow fine (16 bit) zone 3 Fine blue (yellow) LEDs saturation control	proportional
29	-	-	-	37	29	0-255	White (8 bit) zone 3 <i>If RGBW mode is selected:</i> White colour saturation control coarse (0-100%) <i>If CMY mode is selected:</i> No function	proportional
30	-	-	-	38	30	0-255	White fine (16 bit) zone 3 Fine white LEDs saturation control (RGBW mode)	proportional
31	15	11	-	13	31	0	CTC No function	step
						1-255	Colour temperature correction from 20000K to 2700K (<i>menu item "Colour Calibration Mode"=Off</i>)	proportional
						1-255	Colour temperature correction from 15500K to 2700K (<i>menu item "Colour Calibration Mode"=On</i>)	proportional
32	16	12	7	14	32	0	Virtual Colour Wheel For detailed description see " Virtual colour wheel- colour mixing chart No function	step
						1-2	White 2700 K	step
						3	White 2700 K (Halogen lamp mode**)	step
						4-5	White 3200 K	step
						6	White 3200 K (Halogen lamp mode**)	step
						7-9	White 4200 K	step
						10-12	White 5600 K	step
						13-15	White 8000 K	step
						16	Blue (Blue=full, Red+Green+White=0)	step
						17-55	Red=0, Green->up, Blue =full, White=0	proportional
						56	Light Blue (Red=0, Green=full, Blue =full, White=0)	step
						57 - 95	Red=0, Green=full, Blue->down, White=0	proportional
						96	Green (Red=0, Green=full, Blue =0, White=0)	step
						97 - 134	Red->up, Green=full, Blue=0, White=0	proportional
						135	Yellow (Red=full, Green=full, Blue=0, White=0)	step
						136 - 174	Red=full, Green->down, Blue=0, White=0	proportional
						175	Red (Red=full, Green=0, Blue=0, White=0)	step
						176 -214	Red=full, Green=0, Blue->up, White=0	proportional
						215	Magenta (Red=full, Green=0, Blue=full, White=0)	step
						216 - 246	Red -> down, Green=0, Blue=full, White=0	proportional
247	Blue (Red=0, Green=0, Blue=full, White=0)	step						
----- <i>Speed of the following effects can be controlled by the Shutter/Strobe channel (DMX values of 96-127)</i>								
						248	Rainbow effect (with fade time)	step
						249	Rainbow effect	step
						250	Zone effect 1	step
						251	Zone effect 2	step
						252	Zone effect 3	step
						253	Zone effect 4	step
						254	Zone effect 5	step
						255	Zone effect 6	step

Mode/Channel						Value	Function	Type of control
1	2	3	4	5	6			
33	17	13	8	9	-	0-127 128-191 192-255	Beam shaper Beam shaper indexing 0°-180° Forwards rotation from fast to slow Backwards rotation from slow to fast	proportional proportional proportional
34	18	14	9	7	33	0 - 255	Zoom (8 bit) Zoom from min. to max. beam angle	proportional
35	19	-	-	8	34	0 - 255	Zoom fine (16 bit) Fine zooming from min. to max.	proportional
36	20	15	10	10	35	0-31	Shutter closed	step
						32-63	Strobe effect from slow--> fast (zone 3 only)	proportional
						64-95	Strobe effect from slow--> fast (All zones together)	proportional
						-----Set value on Virtual colour wheel-----		
						96-111	Zone effects+rainbow effects speed control, slow--> fast	proportional
						112-127	Zone effects+rainbow effects speed control, fast--> slow / opposite direction/	proportional
						128-143	Opening pulses in sequences from slow--> fast (All zones together)	proportional
						144-159	Closing pulses in sequences from fast--> slow (All zones together)	proportional
36	20	15	10	10	35	160-175	Random strobe effect from slow--> fast (random zone)	proportional
						176-191	Random strobe effect from slow--> fast (random zone + random strobe)	proportional
						192-223	Random strobe effect from slow --> fast (All zones together)	proportional
						224-255	Shutter open	step
37	21	16	11	11	36	0-255	Dimmer (8 bit) Dimmer intensity from 0% to 100%	proportional
38	22	-	-	12	37	0-255	Dimmer fine (16 bit) Fine dimming	proportional

**In the Halogen lamp mode the Dimmer channel imitates behaviour of the halogen lamp during dimming.

6.1 Virtual colour wheel - colour mixing chart

Scale*	Virtual Colour Wheel DMX	Red DMX	Green DMX	Blue DMX	White DMX
	1-2 (White 2700K)	250	118	0	63
	3 (White 2700K /Hal.mode/)	250	118	0	63
	4-5 (White 3200K)	255	141	5	89
	6 (White 3200K /Hal.mode/)	255	141	5	89
	7-9 (White 4200K)	254	141	3	255
	10-12 (White 5600K)	254	207	37	255
	13-15 (White 8000K)	228	255	79	255
	16	0	0	255	0
	17	0	3	255	0
	18	0	6	255	0
	19	0	9	255	0
	20	0	12	255	0
	21	0	15	255	0
	22	0	18	255	0
	23	0	21	255	0
	24	0	24	255	0
	25	0	27	255	0
	26	0	30	255	0
	27	0	36	255	0
	28	0	41	255	0
	29	0	46	255	0
	30	0	52	255	0
	31	0	58	255	0
	32	0	64	255	0
	33	0	68	255	0
	34	0	74	255	0
	35	0	80	255	0
	36	0	86	255	0
	37	0	92	255	0
	38	0	98	255	0
	39	0	104	255	0
	40	0	110	255	0
	41	0	119	255	0
	42	0	129	255	0
	43	0	138	255	0
	44	0	147	255	0
	45	0	156	255	0
	46	0	165	255	0
	47	0	174	255	0
	48	0	183	255	0
	49	0	192	255	0
	50	0	201	255	0
	51	0	210	255	0
	52	0	219	255	0
	53	0	228	255	0
	54	0	237	255	0
	55	0	246	255	0
	56	0	255	255	0
	57	0	255	246	0
	58	0	255	237	0
	59	0	255	228	0
	60	0	255	219	0
	61	0	255	210	0
	62	0	255	201	0
	63	0	255	192	0

Scale*	Virtual Colour Wheel	Red	Green	Blue	White
	DMX	DMX	DMX	DMX	DMX
	64	0	255	183	0
	65	0	255	174	0
	66	0	255	165	0
	67	0	255	156	0
	68	0	255	147	0
	69	0	255	138	0
	70	0	255	129	0
	71	0	255	119	0
	72	0	255	110	0
	73	0	255	104	0
	74	0	255	98	0
	75	0	255	92	0
	76	0	255	86	0
	77	0	255	80	0
	78	0	255	74	0
	79	0	255	68	0
	80	0	255	64	0
	81	0	255	58	0
	82	0	255	52	0
	83	0	255	46	0
	84	0	255	41	0
	82	0	255	36	0
	86	0	255	30	0
	87	0	255	27	0
	88	0	255	24	0
	89	0	255	21	0
	90	0	255	18	0
	91	0	255	15	0
	92	0	255	12	0
	93	0	255	9	0
	94	0	255	6	0
	95	0	255	3	0
	96	0	255	0	0
	97	3	255	0	0
	98	6	255	0	0
	99	9	255	0	0
	100	12	255	0	0
	101	15	255	0	0
	102	18	255	0	0
	103	21	255	0	0
	104	24	255	0	0
	105	27	255	0	0
	106	30	255	0	0
	107	36	255	0	0
	108	41	255	0	0
	109	46	255	0	0
	110	52	255	0	0
	111	58	255	0	0
	112	64	255	0	0
	113	68	255	0	0
	114	74	255	0	0
	115	80	255	0	0
	116	86	255	0	0
	117	92	255	0	0
	118	98	255	0	0

Scale*	Virtual Colour Wheel	Red	Green	Blue	White
	DMX	DMX	DMX	DMX	DMX
	119	104	255	0	0
	120	110	255	0	0
	121	119	255	0	0
	122	129	255	0	0
	123	138	255	0	0
	124	147	255	0	0
	125	156	255	0	0
	126	165	255	0	0
	127	174	255	0	0
	128	183	255	0	0
	129	192	255	0	0
	130	201	255	0	0
	131	210	255	0	0
	132	219	255	0	0
	133	228	255	0	0
	134	240	255	0	0
	135	255	255	0	0
	136	255	246	0	0
	137	255	237	0	0
	138	255	228	0	0
	139	255	219	0	0
	140	255	210	0	0
	141	255	201	0	0
	142	255	192	0	0
	143	255	183	0	0
	144	255	174	0	0
	145	255	165	0	0
	146	255	156	0	0
	147	255	147	0	0
	148	255	138	0	0
	149	255	129	0	0
	150	255	119	0	0
	151	255	110	0	0
	152	255	104	0	0
	153	255	98	0	0
	154	255	92	0	0
	155	255	86	0	0
	156	255	80	0	0
	157	255	74	0	0
	158	255	68	0	0
	159	255	64	0	0
	160	255	58	0	0
	161	255	52	0	0
	162	255	46	0	0
	163	255	41	0	0
	164	255	36	0	0
	165	255	30	0	0
	166	255	27	0	0
	167	255	24	0	0
	168	255	21	0	0
	169	255	18	0	0
	170	255	15	0	0
	171	255	12	0	0
	172	255	9	0	0
	173	255	6	0	0

Scale*	Virtual Colour Wheel DMX	Red DMX	Green DMX	Blue DMX	White DMX
	174	255	3	0	0
	175	255	0	0	0
	176	255	0	3	0
	177	255	0	6	0
	178	255	0	9	0
	179	255	0	12	0
	180	255	0	15	0
	181	255	0	18	0
	182	255	0	21	0
	183	255	0	24	0
	184	255	0	27	0
	185	255	0	30	0
	186	255	0	36	0
	187	255	0	41	0
	188	255	0	46	0
	189	255	0	52	0
	190	255	0	58	0
	191	255	0	64	0
	192	255	0	68	0
	193	255	0	74	0
	194	255	0	80	0
	195	255	0	86	0
	196	255	0	92	0
	197	255	0	98	0
	198	255	0	104	0
	199	255	0	110	0
	200	255	0	119	0
	201	255	0	129	0
	202	255	0	138	0
	203	255	0	147	0
	204	255	0	156	0
	205	255	0	165	0
	206	255	0	174	0
	207	255	0	183	0
	208	255	0	192	0
	209	255	0	201	0
	210	255	0	210	0
	211	255	0	219	0
	212	255	0	228	0
	213	255	0	237	0
	214	255	0	246	0
	215	255	0	255	0
	216	246	0	255	0
	217	237	0	255	0
	218	228	0	255	0
	219	219	0	255	0
	220	210	0	255	0
	221	201	0	255	0
	222	192	0	255	0
	223	183	0	255	0
	224	174	0	255	0
	225	165	0	255	0
	226	156	0	255	0
	227	147	0	255	0
	228	138	0	255	0

Scale*	Virtual Colour Wheel	Red	Green	Blue	White
	DMX	DMX	DMX	DMX	DMX
	229	129	0	255	0
	230	119	0	255	0
	231	110	0	255	0
	232	104	0	255	0
	233	98	0	255	0
	234	91	0	255	0
	235	84	0	255	0
	236	77	0	255	0
	237	70	0	255	0
	238	63	0	255	0
	239	56	0	255	0
	240	49	0	255	0
	241	42	0	255	0
	242	35	0	255	0
	243	28	0	255	0
	244	21	0	255	0
	245	14	0	255	0
	246	7	0	255	0
	247	0	0	255	0
	248-255 (Rainbow+ zone effects)	****	****	****	****

* Colour scale as an illustration only

6.2 LED zone order

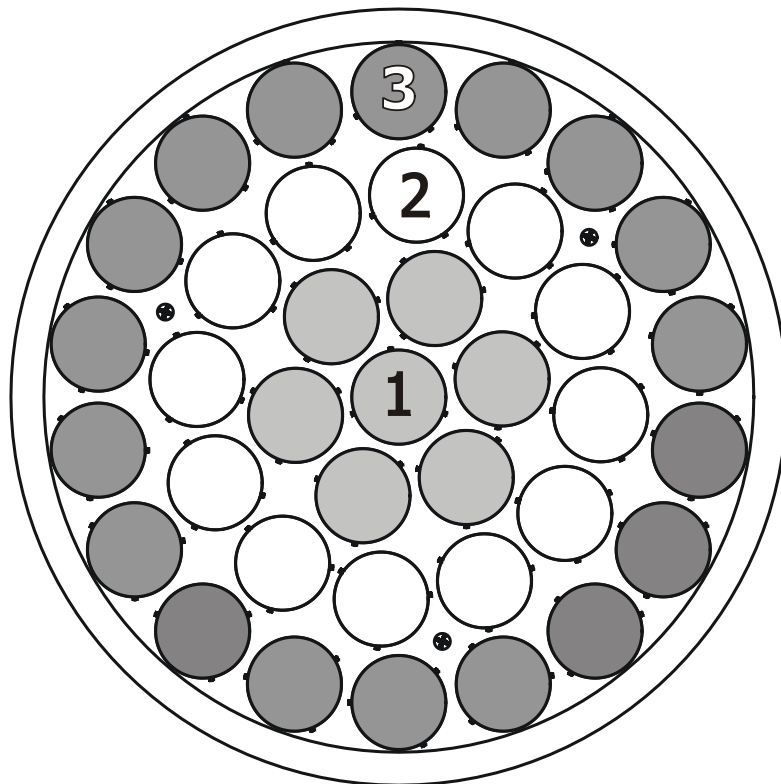

7. Control menu

The Robin 800 LEDWash Light is equipped with the QVGA Robe touch screen with battery backup which allows to set the fixture's behaviour according to your needs, obtain information on its operation, test its various parts and lastly program it, if it has to be used in a stand-alone mode. The fixture's menu can be controlled either by the control buttons or directly by touching the icon.

Control buttons on the front panel:

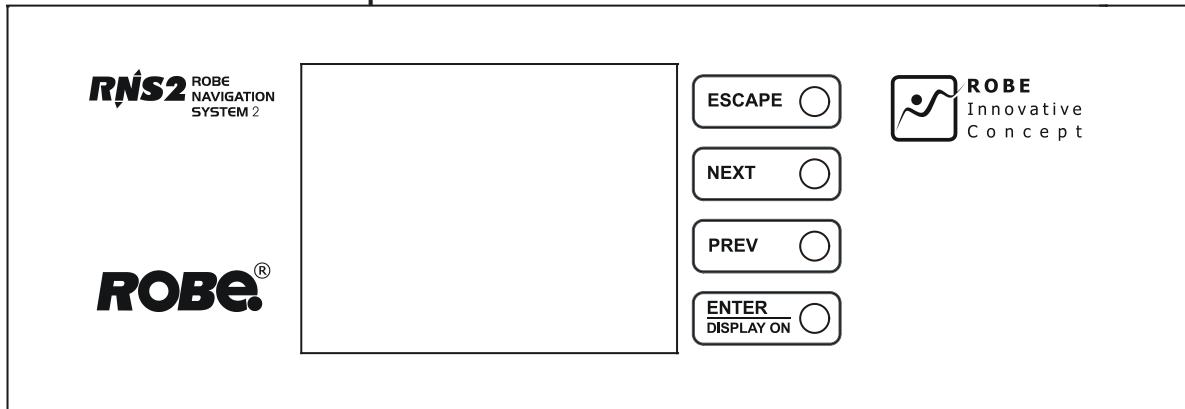

[ESCAPE] button used to leave the menu without saving changes.

[NEXT] , [PREV] buttons for moving between menu items and symbols, adjusting values.

[ENTER/Display On] button used to enter the selected menu (menu item) and to confirm adjusted value.

If the fixture is disconnected from mains, the button switches the touch screen on.

Icons used in the touch screen menu:



- [back arrow] used to move back to the previous screen (menu).



- [up arrow] used to move up on the previous page.



- [down arrow] used to move down on the next page.



- [confirm] used to save adjusted values, to leave menu or to perform desired action.



- [cancel] used to leave menu item without saving changes.



- [confirm+copy] used to save adjusted values and copy them to the next prog. step.



- [warning icon] used to indicate some error which has occurred in the fixture.



- [Ethernet] used to indicate Ethernet connected.



- [display turn] used to turn the display by 180°.

The menu page displays icons for each function that you can perform from the touch screen.

After switching the fixture on, the touch screen shows the screen with the ROBE logo:

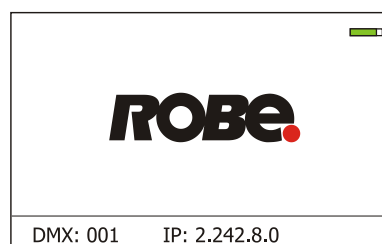

Note: The green icon at the top right corner of the screen indicates the level of the display battery charging. If the whole icon is green, the battery is fully charged while the red icon indicates exhausted battery. The battery charges during fixture operation, its charging lasts cca 6 hours.

We recommend that the fixture should be in operation at least 7 hours per week to keep the battery fully charged. If you switch the fixture on and this screen will not appear till 1 minute, switch the fixture off and on again. If the screen lights, the battery is exhausted. In case the screen still does not light, the battery is faulty.

This is also indicated by an error message "Faulty battery" and if such an error message appears the battery should be replaced immediately. The lifetime of the battery is highly dependent on ambient temperature (and consequently on base temperature). If the maximum ambient temperatures (as recorded and displayed in menu: Information -> Fixture Temperatures -> Ambient Temperature -> Maximum NonRes.) are kept within the specified limits, the battery should last for at least two years. Should the ambient temperatures exceed the specified maximum temperature, the lifetime of the batteries could be considerably shortened even up to just one year or less and also result in physical damage (battery leakage) or unreliable fixture functions.

Damage caused by batteries failed due to exceeded maximum ambient temperature cannot be claimed under warranty terms.

Touch any part of the screen or press the [ENTER/Display On] button to display the initial screen with the current stored DMX address:

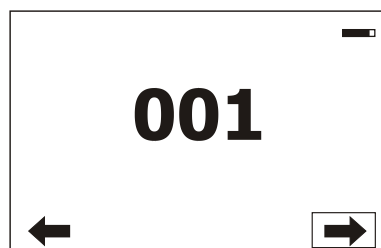

Touch the green arrow at the bottom right corner of the screen or press the [ENTER/Display On] button to enter the "Address" menu.

An item (such as a Tab, menu item, text box, icon) may be selected from a screen by simply touching the item in the list or by pressing the [NEXT] or [PREV] buttons to scroll through list items. With each press, the next item is highlighted. Press [ENTER/Display On] to select the highlighted item.

Before first fixture operation, set current date and time in the menu "Date & Time Settings" (menu path: Personality--> Date & Time Settings).

7.1 Tab "Address"



Settings - Select the menu to set desired fixture address setting.

DMX Address - Select the menu to set the DMX start address.

Ethernet Settings - The menu allows all needed settings for the Ethernet operation

Ethernet Mode - Use the menu to set the Ethernet operation mode:

Disable - The option disables Ethernet operation.

Artnet - Fixture receives Artnet protocol - every fixture has to be connected to the network.

gMAI - Fixture receives MANet protocol.

gMA2 - Fixture receives MANet2 protocol.

Art2DMX - Fixture receives Artnet protocol from the Ethernet input and sends DMX data to its DMX output (fixture works as an "Artnet/DMX converter", next fixture can be connected to its DMX output and you can build a standard DMX chain by connecting another fixtures. Only one fixture has to be connected to the Ethernet.

IP Address/Net Mask - Select this menu to set IP address. IP address is the Internet protocol

address. The IP uniquely identifies any node (fixture) on a network.

There cannot be 2 fixtures with the same IP address on the network!

Default IP Address - Preset IP address, you can set up only first byte of IP address (2 or 10) e.g. **002**.019.052.086.

Custom IP Address - The option enables to set up all bytes of IP address.

Net Mask - The option enables to set up all bytes of Net Mask.

ArtNet Universe - Use this item to set a Universe (0-255). The Universe is a single DMX 512 frame of 512 channels.

MANet Settings - Use this menu to set parameters for MANet operation.

MANet I/II Universe - The value of this item can be set in range 1-256.

MANet Session ID - The value of this item can be set in range 1-32.

7.2 Tab "Information"



Fixture Times - The menu provides readouts of fixture operation hours.

Power On Time Hours - Select this menu to read the number of fixture operation hours.

Total Hours - The item shows the total number of the operation hours since the Robin 800 LEDWash has been fabricated.

Resetable Hours - The item shows the number of the operation hours that the Robin 800 LEDWash has been powered on since the counter was last reset.

In order to reset this counter to 0, touch the text box next to the item "Resetable Hours:"

Fixture Temperatures - The menu is used to view temperatures of the fixture's inside.

LEDs Temperature - The menu shows temperatures in the LED module.

Current - A current temperature of the LED module.

Maximum NonRes. - A maximum temperature of the the LED module since the fixture has been fabricated.

Maximum Res. - A maximum temperature of the the LED module since the counter was last reset.

In order to reset this counter to 0, touch the text box next to the item "Maximum Res."

Ambient Temperature - The menu shows temperature of the induced air on the fan in the fixture base .

Current - A current temperature of the induced air in the fixture base.

Maximum NonRes. - A maximum temperature of the induced air in the fixture base since the fixture has been fabricated.

Maximum Res. - A maximum temperature of the induced air in the fixture base since since the counter was last reset.

In order to reset this counter to 0, touch the text box next to the item "Maximum Res."

Base Temperature - The menu shows temperature in the fixture base.

Current - A current temperature in the fixture base.

Maximum NonRes. - A maximum temperature in the fixture base since the fixture has been fabricated.

Maximum Res. - A maximum temperature in the fixture base since the counter was last reset.

In order to reset this counter to 0, touch the text box next to the item "Maximum Res."

DMX Values - The menu is used to read DMX values of each channel received by the fixture.

Wireless State - The menu serves for reading of the wireless operation status (only for Wireless DMX version).

Unlink Wireless Adapter - The item serves for unlinking the fixture from the transmitter.

Product IDs - The menu is used to read the MAC Address ,RDM UID and RDM Label.

Software Version - Select this item to read the software version of the fixture modules:

Display System - A display processor on the display board in the fixture base

Module M - A pan/Tilt processor on the main board in the fixture arm

Module L - Zoom and LED control processor on the board in the fixture head.

View Logs - Use this menu to read fixture's data which have been recorded during fixture operation. This collected data allows easier troubleshooting.

Fixture Errors - Use this menu to read fixture errors which have occurred during fixture operation.

Fixture States - Recorded following actions: Fixture On, Fixture Off.

Fixture Position - Recorded installation positions of the fixture:

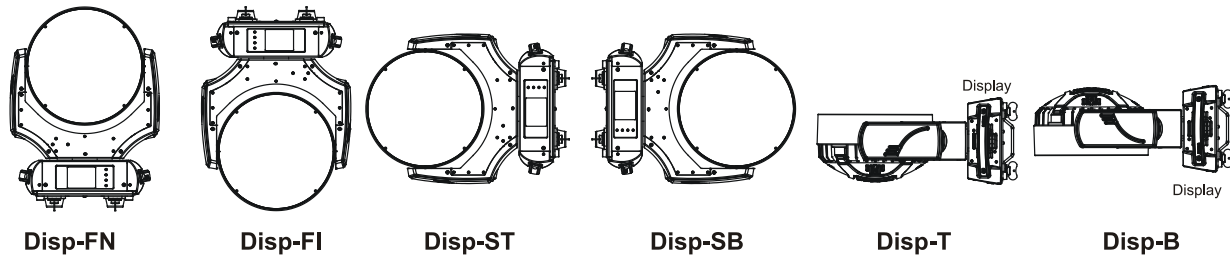

Fixture Temperatures - Recorded temperatures which have exceeded defined levels.

7.3 Tab "Personality"



User mode - The Robin 800 LEDWash allows you to recall up to 3 user settings. After switching the fixture on for the first time, the User A settings is active. Now all changes made in the "Personality" menu, "Addressing" menu and the "Music Trigger" and "Preset Playback" items from the "Stand-alone" menu are saved to the User A settings. If you now select the User B settings, from this moment the changes made in these menus will be saved to the User B settings. After switching the fixture off and on, the User B setting is active. In this way you may use the 3 fixture operating behaviours.

User A Settings - the function recalls the user A settings.

User B Settings - the function recalls the user B settings.

User C Settings - the function recalls the user C settings.

DMX Preset - Use the menu to select desired DMX mode.

Mode 1 - 38 control channels

Mode 2 - 22 control channels

Mode 3 - 16 control channels

Mode 4 - 11 control channels

Mode 5 - 38 control channels

Mode 6 - 37 control channels (compatible with LEDWash 600 mode1)

View Selected Preset - Use the menu to display channels included in the selected mode.

DMX Input - Use the menu to select mode of receiving DMX signal.

Wired - DMX signal is received by means of the standard DMX cable.

Wireless - DMX signal is received by means of the inbuilt wireless module.

Wireless In/XLR Out - the fixture receives wireless DMX and sends the signal to its wired DMX output.

The fixture behaves as "Wireless/Wired" adapter.

The options "Wired" and "Wireless" are also stated in DMX chart (channel Power/Special functions).

Pan/Tilt Settings - Use the menu set behaviour of both pan and tilt movements.

Pan Reverse - The item allows to invert pan movement.

Tilt Reverse - The item allows to invert tilt movement.

Pan/Tilt Feedback - The item allows to return the mowing head to the required pan/tilt position after changing the position by an external force if this option is set on.

Note. Be careful, the Pan/Tilt Feedback should be permanent On, the option Off is not suitable for standard operation and the head of the fixture can be damaged!

Pan/Tilt mode - Use this menu to set the mode of the pan/tilt movement

Time mode - The pan and tilt will move with different speeds and they will come at the same time to the end point of their tracks (pan and tilt use their optimal speeds).

Time of the pan/tilt movement (25.5 sec. max.) is set by the channel "Pan/Tilt speed, Pan/Tilt

time".

Speed Mode - Both Pan and tilt will move with the same speed as adjusted at the channel "Pan/Tilt speed, Pan/Tilt time".

Tilt Movement Range - Use this menu to set the range of the tilt movement of the fixture's head

Stand. – Standard range 0-300°.

Reduc. - Reduced range 0-210°. This option must be selected when the top hat is installed otherwise fixture's head runs into base.

Microphone Sensitivity - Enter the menu if you want to adjust the microphone sensitivity from 1 (max.) to 20 (min.).

Blackout Settings - Use the menu if you need to close the light output under certain conditions which are described below

Blackout DMC - Blackout during movement correction. Set this option On if you wish to close light output during the time when the head goes to its correct position, which has been changed by an external force.

Active Blackouts - Use this menu if you wish to close the light output during effect changes.

Pan/Tilt Moving - The menu item enables to close light output while the pan/tilt coordinates are changing.

Colour Calibration Mode - If the function is on, the white output from the fixture (and also mixed colours) is more uniform. Each colour is dynamically corrected according to the value set in the menu "Calibrate Effects" (Service-> Calibrations-> Calibrate Effects).

Zoom mode - Use this menu to change min. beam angle.

Beam Zoom - Beam angle 8°-63°

Wash Zoom - Beam angle 15°-63°, compatible zoom range with the Robin LEDWash 300/600. These zoom options are also stated in DMX chart (channel Power/Special functions).

Init Effect Positions - Use the menu to set all effects to the desired positions at which they will stay after switching the fixture on without DMX signal connected.

Screen Settings - Use this menu to change the touch screen settings.

Display Intensity - The item allows to control the intensity of the screen (1-min., 10-max.).

Screen saver Delay - The item allows you to keep the screen on or to turn it off automatically after 1-10 minutes after last touch (or pressing any button on the control panel).

Touchscreen Lock - The item allows you to lock the screen after last touch (or pressing any button on the control panel). The time delay can be set in range of 1-10 minutes. To unlock the screen, press the [ENTER/Display On] button.

Recalibrate Touchscreen - The item starts calibration of the touchscreen. Follow the instructions on the screen.

Display Orientation - The menu allows to change display orientation.

Normal - Standard display orientation if the fixture is placed horizontally (e.g. on the ground).

Inverted - Inverted orientation (needed if the fixture is hanging on the truss).

Auto - The option activates a gravitation sensor for automatic screen orientation.

Note: **Auto** option is set as default. You change the display orientation by touching the icon  on the display, and the option set in the "Display Orientation" menu is temporarily overridden.

Temperature unit - Use the menu item to change temperature unit from °C to °F.

Fan Mode - Use the menu to set the fixture fans to max. fan power mode ("**High**") or to auto-control mode ("**Auto**").

Theatre mode - The mode reduces max. pan/tilt and zoom speed in order to provide silent operation of the fixture:

Pan range 0-450°: 3.4 seconds at max. speed.

Tilt range 0-300°: 2.5 seconds at max. speed.

Zoom min-max: 10 seconds at max speed

Date & Time Settings - Use this menu to set current date and time for the fixture log system (menu "**View Logs**"). Set this menu item before first fixture operation.

Default Settings - The menu item allows to set all fixture parameters to the default (factory) values.

7.4 Tab "Manual Control"



Reset Functions - The menu allows to reset the fixture either per function modules or all modules together.

Total System Reset - The item resets all function modules.

Pan/Tilt Reset - The item resets a pan and tilt movement.

Zoom Reset - The item resets a zoom module.

Preset Effect Control - Use the menu to show preset positions of each channel effect.

Manual Effect control - Use the menu to control all fixture channels by means of the control panel.

7.5 Tab "Stand-alone"



Test Sequences - Use the menu to run a test/demo sequences without an external controller, which will show you some possibilities of using Robin 800 LEDWash.

Dynamic Mode - This mode uses all Robin 800 LEDWash functions including pan/tilt movement and therefore is good for a complete introduction of the fixture.

Static Mode - This mode is suitable for projections on the wall, ceiling or ground without any pan/tilt movement. Adjust the pan, tilt and zoom to desired positions and start test sequences by touching the green ► icon.

Music Trigger - Use the item to activate the sound control of the running program via the built-in microphone.

Preset Playback - This menu allows you to select the program which will be played in a loop after switching the fixture on (the option is commonly used in a stand-alone operation without an external controller).

None - The option disables "Presetting playback" function.

Test - The option starts the test sequences.

Prog. 1 - The option starts user program No. 1.

Prog. 2 - The option starts user program No. 2.

Prog. 3 - The option starts user program No. 3.

Play program - Use the menu to run desired program in a loop.

Play Program 1 - The option starts user program No. 1.

Play Program 2 - The option starts user program No. 2.

Play Program 3 - The option starts user program No. 3.

Edit Program - Use the menu to create or to edit desired program. The Robin 800 LEDWash offers 3 free programs, each up to 100 steps.

Edit Program 1 - The option allows to edit user program No. 1.

Edit Program 2 - The option allows to edit user program No. 2.

Edit Program 3 - The option allows to edit user program No. 3.

To edit program:

1. Touch the item which you want to edit ("Edit Program 1" - "Edit Program 3").
2. Touch the item "Edit Program Steps".
3. Touch the item "Step 1".
4. From the list of effects touch desired effect and set its value. Browse through the list by touching the [up arrow] and [down arrow] and set all desired effects.
An item "Step Time" (value of 0-25.5 sec.) is the time during which effects last in the current step
5. Save adjusted effects to the current step by touching the [confirm] or save and copy them to the following step by touching the [confirm+copy]. By touching the text box "Preview" next to the current program step you can view created scene.
6. Repeat the steps 4 and 5 for next program steps.
7. After editing desired program steps, adjust the length of the program by touching the text boxes "Start Step" and "End Step".

Meaning of the icons used in the "Edit Program" menu:

⬇️ - moves down on the next page ✓ - saves adjusted values and leaves menu

↑ - moves up on the previous page ✓ - saves values to the current step and copy them to the following prog. step

✗ - leaves menu without saving values

There is a chart describing behaviour of items "Pan/Tilt Macro" and "P./T. Macro Speed".

DMX	Pan/Tilt Macro
0 - 9	Disabled pan/tilt macro
10 - 31	Reserved
32 - 63	Figure of circle (from small to large)
64 - 95	Figure of horizontal eight (from small to large)
96 - 127	Figure of vertical eight (from small to large)
128 - 159	Figure of rectangle (from small to large)
160 - 191	Figure of triangle (from small to large)
192 - 223	Figure of star (from small to large)
224 - 255	Figure of cross (from small to large)
	Pan/Tilt Macro Speed
0	No macro generation
	Macro generation from fast to slow-forwards
	No macro generation
	Macro generation from slow to fast-backwards

7.6 Tab "Service"



Adjust DMX Values - The menu allows you to set all effects to desired positions before fine calibration of the effects .

Calibrations - This menu enables fine calibration of fixture effects and download default calibration values.

Calibrate Effects - The menu allows the fine adjustment of effects.

Pan- a pan position fine adjustment

Tilt - a tilt position fine adjustment

Beam shaper- a beam shaper module

Calibrate Colours - The menu serves for adjusting of LEDs saturation to achieve colour temperature of 5600K for white output.

Red - a red LEDs saturation fine adjustment

Green - a green LEDs saturation fine adjustment

Blue - a blue LEDs saturation fine adjustment

White - a white LEDs saturation fine adjustment

By using these items you can calibrate and adjust effects to desired positions.

Calibration of the pan/tilt via the control board

1. Disconnect DMX controller from the fixture and enter the "Calibrate Effects" menu.
2. Use the [up arrow] and [down arrow] to find "Pan" and touch it to enter the fine effect adjustment screen.
3. Set desired value and save it by touching the [confirm].
4. Repeat steps 2 and 3 for next item.
5. After calibrating all effects, touch the [confirm] to save all adjusted values and reset the fixture.

Calibration of the colour saturations via the control board

1. Disconnect DMX controller from the fixture , open shutter and dimmer and set the Virtual cpl. wheel channel to DMX=10 (white 5600K). Aim the light beam on the lux meter (e.g. Minolta CL-200 Chroma meter) which is placed at min distance of 2.5m from the fixture
2. Set the menu item "Colour Calibration Mode" to On (Personality-> Colour Calibration Mode-> On).
3. Enter the menu "Calibrate Effects".
4. Use the [up arrow] and [down arrow] to find desired colour and touch it to enter the fine effect adjustment screen.
5. By means of the Red, green, Blue and White items adjust the 5600K colour temperature as exactly as possible ($\Delta u'v' = 0$).

7. After adjusting 5600K colour temperature, touch the [confirm] to save all adjusted values and reset the fixture.

Note: you can also use DMX controller for both calibrations stated above, calibration protocol is the following:

<i>Effect</i>	<i>Mode 1</i>	<i>Mode 2</i>	<i>Mode 3</i>	<i>Mode 4</i>	<i>Mode 5</i>
Pan-fine movement	channel 38	channel 22	channel 16	channel 11	channel 38
Tilt - fine movement	channel 39	channel 23	channel 17	channel 12	channel 39
Beam shaper-fine mov.	channel 40	channel 24	channel 18	channel 13	channel 40
Red - red saturation	channel 41	channel 25	channel 19	channel 14	channel 41
Green- green saturation	channel 42	channel 26	channel 20	channel 15	channel 42
Blue - blue saturation	channel 43	channel 27	channel 21	channel 16	channel 43
White - white saturation	channel 44	channel 28	channel 22	channel 17	channel 44

Load Default Calibrations - The item loads default (factory) calibration values.

Updating software - The menu item allows you to update software in the fixture via either serial or USB port of PC.

The following are required in order to update software:

- PC running Windows 95/98/2000/XP or Linux
- DMX Software Uploader
- Flash cable RS232/DMX No.13050624 (if you want to use a serial port of PC)
- Robe Universal Interface (if you want to use an USB port of PC)

Note 1: Software update should execute a qualified person. If you lack qualification, do not attempt the update yourself and ask for help your ROBE distributor.

Note 2: DMX address, IP address, programs 1-3 and all items in the menu "Personality" will be set to their default (factory) values.

To update software in the fixture:

I. Installation of the DMX Software Uploader.

1. DMX Software Uploader program is available from the ROBE web site at WWW.robe.cz.
2. Make a new directory (e.g. Robe_Uploader) on your hard disk and download the software to it.
3. Unpack the program from the archive. If the Robe fixture is produced in both magnetic and electronic ballast version, name of DMX Software Uploader is the same for both versions.

II. Fixture software updating.

1. Determine which of your ports is available on your PC and connect it:

- with the DMX input of the fixture if you using the flash cable RS232/DMX
- with the DMX output of the Robe Universal Interface if you using the USB cable.

Disconnect the fixture from the other fixtures in a DMX chain. Turn both the computer and the fixture on. Make sure the lamp is switched off (only if the fixture involves a lamp).

2. Switch the fixture to the updating mode by touching the "Updating Software " item

Note: If you do not want to continue in software update, you have to switch off and on the fixture to escape from this menu.

We recommend to cancel all running programs before starting the Software Uploader.

3. Run the Software Uploader program. Select desired COM and then click on the Connect button.

(Select COM if the serial port is used or Robe Universal Interface if the USB port is used).

If the connection is OK, click on the "Start Uploading button" to start uploading. It will take several minutes to perform software update.

If the option "Incremental Update" is not checked, all processors will be updated (including processors with the same software version).

If you wish to update only later versions of processors, check the "Incremental Update box".

Avoid interrupting the process. Update status is being displayed in the Info Box window.

When the update is finished, the line with the text "The fixture is successfully updated" will appear in this window and the fixture will reset with the new software.

Note: In the case of an interruption of the upload process (e.g. power cut), the fixture keeps the updating mode and you have to repeat the software update again.

8. RDM

This fixture supports RDM operation. RDM (Remote Device Management) is a bi-directional communications protocol for use in DMX512 control systems, it is the new open standard for DMX512 device configuration and

status monitoring.

The RDM protocol allows data packets to be inserted into a DMX512 data stream without adversely affecting existing non-RDM equipment. By using a special „Start Code,“ and by complying with the timing specifications for DMX512, the RDM protocol allows a console or dedicated RDM controller to send commands to and receive messages from specific moving lights.

RDM allows explicit commands to be sent to a device and responses to be received from it.

The list of commands for Robin 800 LEDWash is the following.

Parameter ID	Discovery command	SET command	GET command
DISC_UNIQUE_BRANCH	*		
DISC_MUTE	*		
DISC_UN_MUTE	*		
DEVICE_INFO			*
SUPPORTED_PARAMETERS			*
SOFTWARE_VERSION_LABEL			*
DMX_START_ADDRESS		*	*
IDENTIFY_DEVICE		*	*
DEVICE_MODEL_DESCRIPTION			*
MANUFACTURER_LABEL			*
DEVICE_LABEL		*	*
SENSOR_DEFINITION			*
SENSOR_VALUE			*
DISPLAY_INVERT		*	*
DISPLAY_LEVEL		*	*
PAN_INVERT		*	*
TILT_INVERT		*	*
DEVICE_RESET		*	
DMX_PERSONALITY		*	*
DMX_PERSONALITY_DESCRIPTION			*
STATUS_MESSAGES			*
STATUS_ID_DESCRIPTION			*
DEVICE_HOURS			*
PARAMETER_DESCRIPTION			*
ROBE_DMX_INPUT		*	*
ROBE_WIRELESS_UNLINK		*	

9. Error and information messages

Occurred errors during fixture operation are signalled by the yellow warning icon at the bottom line of the screen:



Touch the warning icon or press the [ESCAPE] button to display error messages.

List of error and information messages:

Temper.Sensor Error

The message informs you that the communication between the head temperature sensor and the main processor failed.

Tilt Error 1 (Tilt Error 2)

This message will appear after the reset of the fixture if the head's magnetic-indexing circuit malfunctions (sensor failed or magnet is missing) or the stepping motor is defective or its driving IC on the PCB. The head

is not located in the default position after the reset.

Pan Error 1 (Pan Error 2)

This message will appear after the reset of the fixture if the yoke's magnetic-indexing circuit malfunctions (sensor failed or magnet is missing) or the stepping motor is defective or its driving IC on the PCB. The yoke is not located in the default position after the reset of the fixture.

Faulty battery

The battery on the display board is exhausted and should be replaced immediately.

10. Technical Specifications

Electrical

Power supply:.....electronic auto-ranging
Input voltage range:..... supply 100-240V, 50/60Hz
Fuse:.....T 4 A
Power consumption:.....430W (power factor=0.98)

Optic

Light source: 37 Osram Ostar RGBW multichips (SMT LE RTDUW S2W)
3 zones with individual colour control of each
Typical Lumen Maintenance: 70% @ 60,000 hours
LED life expectancy: 60.000 hours
RGBW or CMY colour mixing +CTC
Beam shaper 8° x°26° installed in fixture

Virtual colour wheel

237 colours including whites (2700K, 3200K, 4200K, 5600K and 8000K)
Halogen lamp effect at whites 2700K and 3200K
Rainbow effect with in both directions with variable speed
Zone effects in both directions with variable speed

Strobe

All LED zones together:
Strobe effect with variable speed (0.3 - 20Hz)
Random strobe pulse-effect with variable speed
Opening/closing pulse effect with variable speed
Independent strobe effect with variable speed (0.3 - 20Hz) at LED zone 3
Random strobe and random LED zone effect

Dimmer

Smooth dimmer from 0 - 100 %

Zoom

Motorized, 8°-63° (Beam mode), 15°-63°(Wash mode)

Pan/Tilt

Pan movement range: 450°
Tilt movement range: 300°
16 bit movement resolution
Automatic Pan/Tilt position correction
Remotely controllable speed of pan/tilt movement for easy programming

Control

Graphic touch screen for fixture setting and addressing
Gravitation sensor for auto screen positioning

Battery backup of the touch screen
Readout fixture usage, receiving DMX values, temperatures, etc
Built-in analyzer for easy fault finding, error messages
Built-in demo sequences
Theatre mode for silent pan/tilt and zoom moving
Silent fans cooling,
Stand-alone operation
3 user editable programs, each up to 100 steps
Supported protocols: USITT DMX 512, RDM, ArtNet, MANet, MANet2
6 DMX modes (38, 22, 16, 11,38, 37 control channels)

Wireless DMX/RDM module

Compliance with USITT DMX-512 (1986 & 1990) and 512-A
Full DMX fidelity and frame integrity
Auto sensing of DMX frame rate and frame size
<5ms DMX latency
Operational frequency range of 2402-2480 MHz
Producer: LumenRadio

Connection

DMX data in/out: Locking 3-pin and 5-pin XLR
AC power input: Chassis connector Neutrik PowerCon, A-type, NAC3MPA
Cable connector Neutrik PowerCon, A-type, NAC3FCA , for power-in, (installed on the power cord)
Ethernet: RJ45

Rigging

Mounting points: 2 pairs of 1/4-turn locks
Mounting horizontally or vertically via 2 Omega brackets
Mounting adapter for one Omega bracket

Temperatures

Maximum ambient temperature : 45° C
Maximum housing temperature : 75° C

Minimum distances

Min. distance from flammable surfaces: 0.5 m
Min. distance to lighted object: 1.0 m

Total heat dissipation

1330 BTU/h (calculated)

Weight (net):

11 kg (with beam shaper)
10.7 kg (with front transparent cover)

Dimensions (mm)

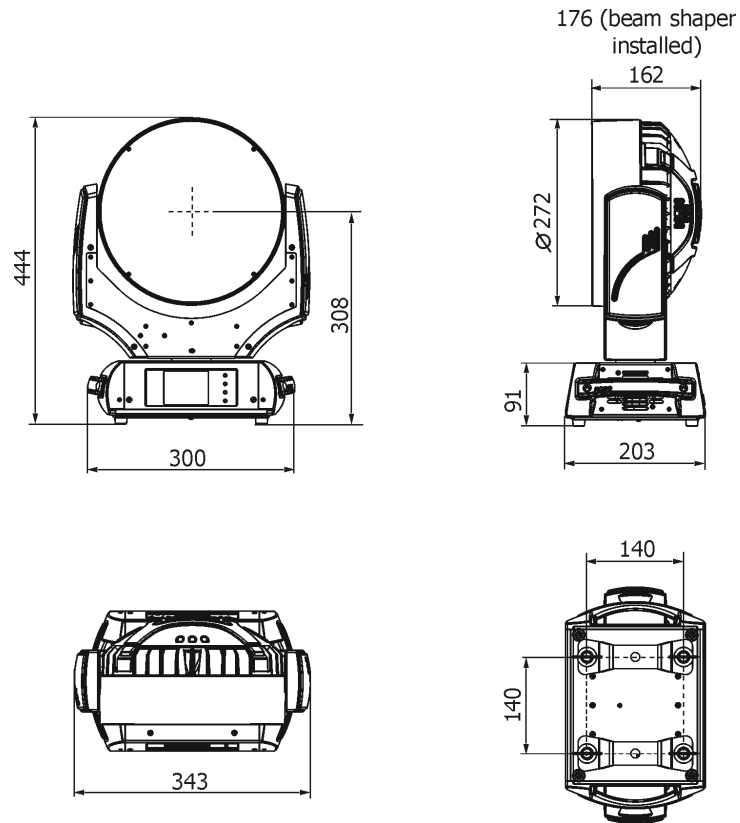

Accessories

- 1 x Omega Adaptor CL-regular 2 pcs (P/N 10980033)
- 1 x Front transparent cover (P/N 99013603)
- 1 x Beam Shaper 8°x26° (P/N 99013549) /installed on the fixture/

Optional accessories

- Top Hat ROBIN 600/800 LEDWash(black) (P/N 10980101)
- Top Hat ROBIN 600/800 LEDWash(white) (P/N.10980103)
- Top Hat ROBIN 600/800 LEDWash(silver) (P/N.10980111)
- Mounting Adaptor for one Omega holder (black) (P/N 10980100)
- Mounting adapter for one Omega holder in neutral - glazy aluminium (P/N 10980113)
- Beam Shaper 19°x35°, optional 800 LW (P/N 10980142)
- EggCrate Robin 800 LEDWash-black (P/N. 10980199)
- Doughty Trigger Clamp (P/N 17030386)
- Safety wire 35 kg (P/N 99011963)

Mounting adaptor for one Omega holder

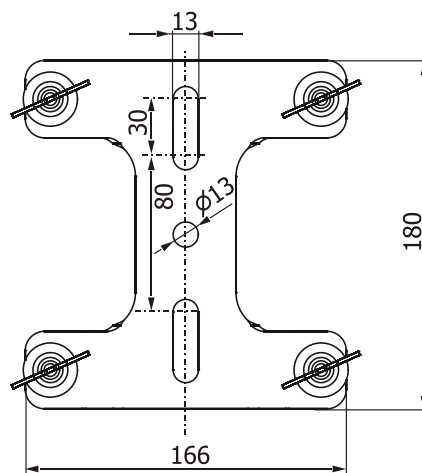

11. Maintenance and cleaning

It is absolutely essential that the fixture is kept clean and that dust, dirt and smoke-fluid residues must not build up on or within the fixture. Otherwise, the fixture's light-output will be significantly reduced. Regular cleaning will not only ensure the maximum light-output, but will also allow the fixture to function reliably throughout its life. A soft lint-free cloth moistened with any good glass cleaning fluid is recommended, under no circumstances should alcohol or solvents be used!

DANGER !
**Disconnect from the mains before starting any
maintenance work**

The head's transparent cover will require weekly cleaning as smoke-fluid tends to building up residues, reducing the light-output very quickly. The cooling fans should be cleaned monthly.

The interior of the base should be cleaned at least annually using a vacuum-cleaner or an air-jet.

More complicated maintenance and service operations are only to be carried out by authorized distributors.

11.1 Replacing fuse

Only replace the fuse by a fuse of the same type and rating.

Before replacing the fuse, unplug mains lead!

If you need to replace the main fuse, follow the instructions:

- 1) Remove the rear cover of the base by unscrewing 6 fastening screws.
- 2) Remove the old fuse from the fuseholder.
- 3) Install the new fuse into the fuseholder.
- 4) Replace the rear cover back to the base.

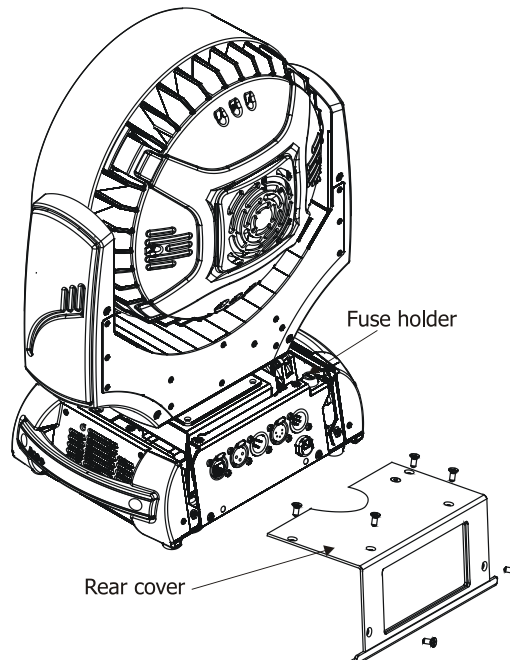

12. ChangeLog

This section summarizes all types of changes in the user manual.

Version of the manual	Date of issue	Description of changes
1.1	25/11/2012	Specification for beam shapper added in chapter 10. Technical Specifications Zoom Mode option added in Personality menu.
1.2	21/02/2013	Photometric diagrams for beam shapers added.
1.3	22/01/2018	Optional accessories changed
1.4	27/04/2018	DMX chart ver. 1.1

13. Photometric diagrams (transparent front cover)

Min. Zoom (Beam mode)

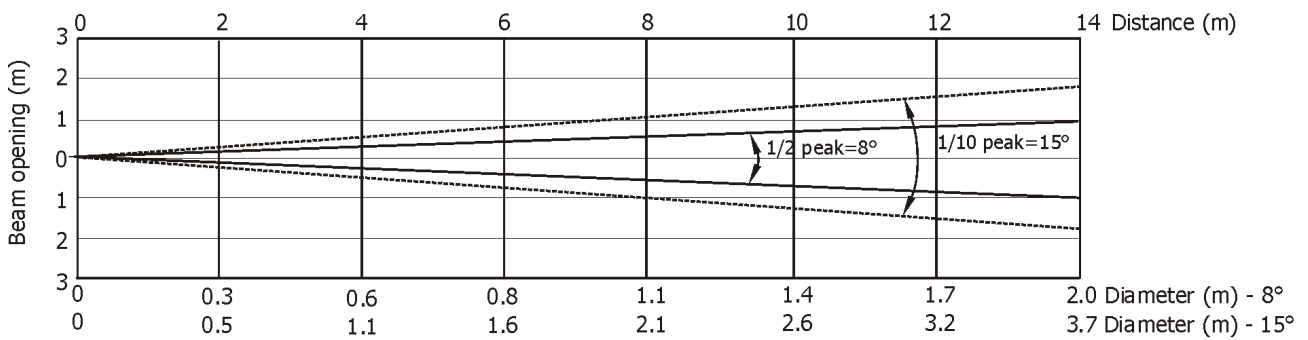

Distance (m)	2	4	5	6	8	10	12	14	
Red	10313/958	2578/240	1650/153	1146/107	645/60	413/38	287/27	211/20	Intensity (center) Lux/Footcandles
Green	23625/2195	5906/549	3780/351	2625/244	1477/137	945/88	656/61	482/45	
Blue	3562/331	891/83	570/53	396/37	223/21	143/13	99/9	73/7	
White	30625/2845	7656/711	4900/455	3403/316	1914/178	1225/114	851/79	625/58	
R+G+B+W	50000/4645	12500/1161	8000/743	5555/516	3125/290	2000/186	1388/129	1024/95	

Illuminance distribution

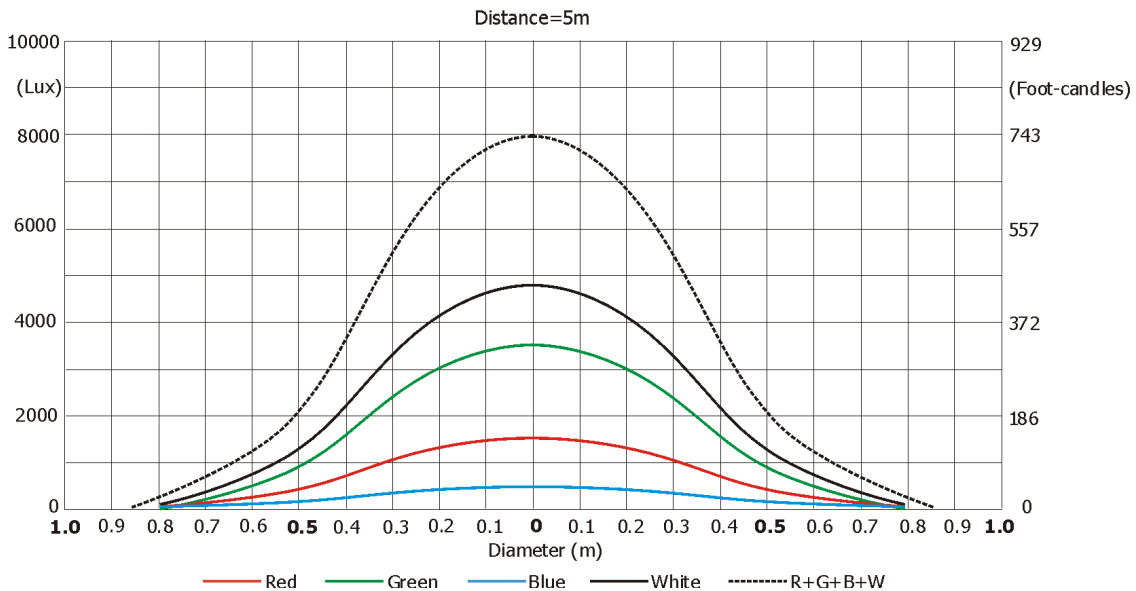

Min. Zoom (Wash mode)

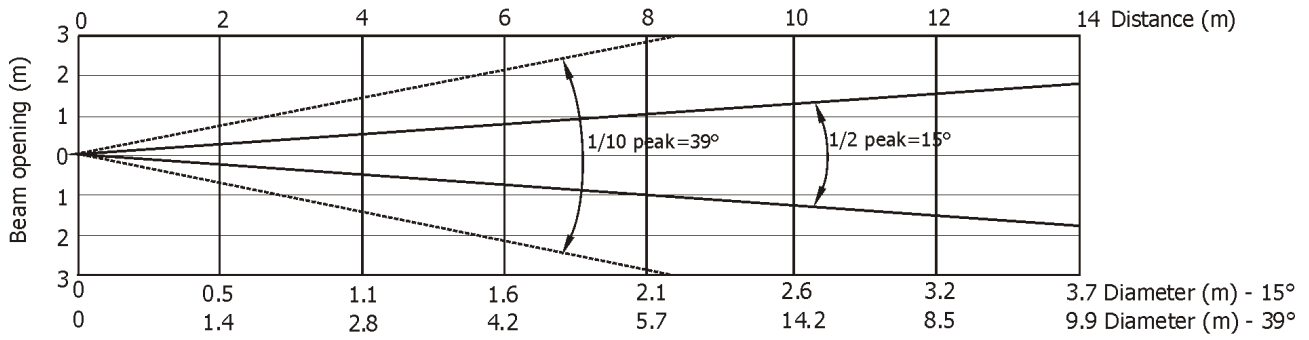

Distance (m)	2	4	5	6	8	10	12	14	
Red	5688/528	1422/132	910/85	632/59	356/33	228/21	158/15	116/11	Intensity (center) Lux/Footcandles
Green	12688/1178	3172/295	2030/189	1410/131	793/74	508/47	352/33	260/24	
Blue	1875/174	469/44	300/28	208/19	117/11	75/7	52/5	38/4	
White	15813/1469	3953/367	2530/235	1757/163	988/92	632/59	439/41	323/30	
R+G+B+W	26875/2497	6719/624	4300/400	2986/277	1680/156	1075/100	747/69	549/51	

Illuminance distribution

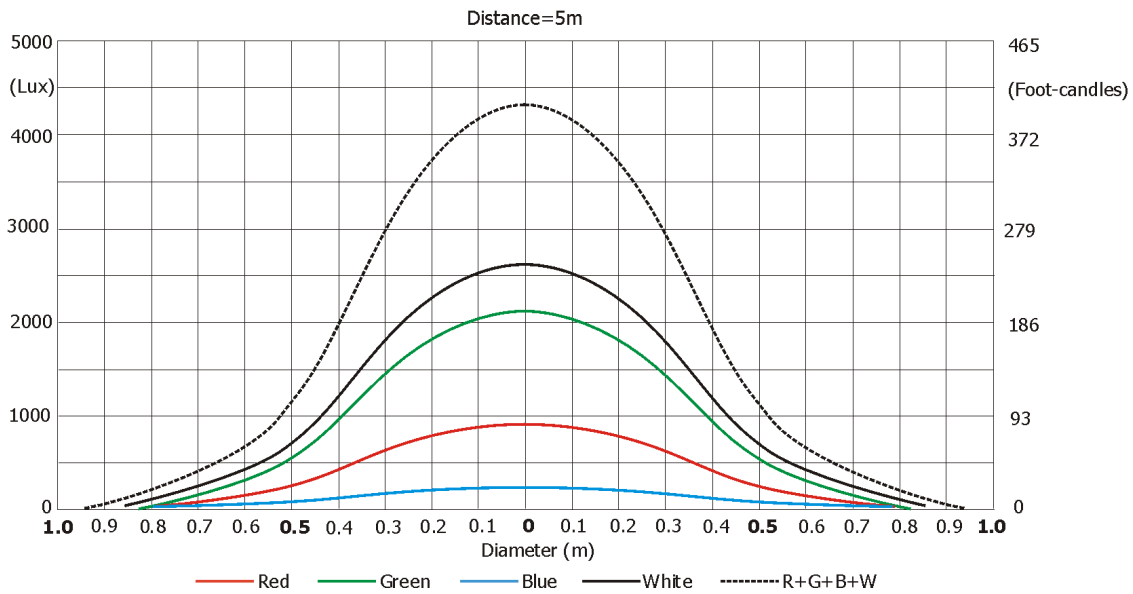

Max. zoom

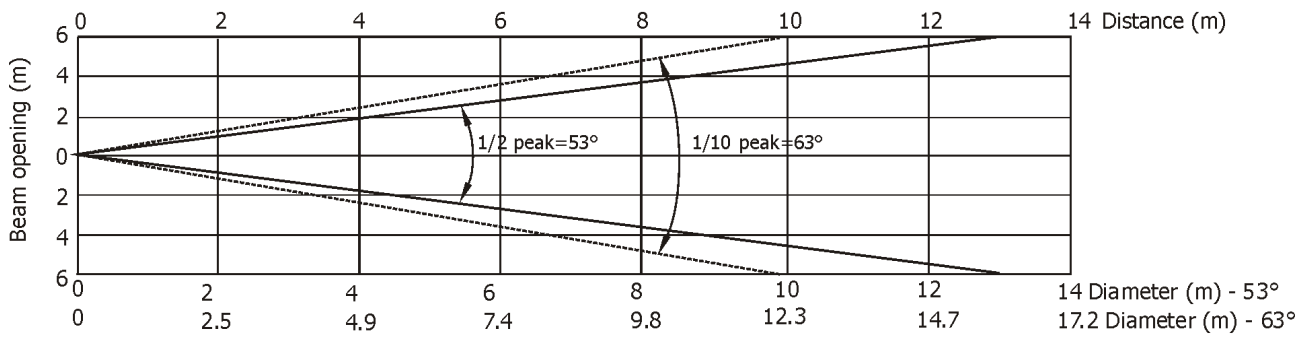

Distance (m)	2	4	5	6	8	10	12	14	
Red	594/55	148/14	95/9	66/6	37/3.4	24/2.2	17/1.5	12/1.1	Intensity (center) Lux/Footcandles
Green	1344/125	336/31	215/20	149/14	84/8	54/5	37/3.5	27/2.5	
Blue	188/17	47/4.4	30/2.8	21/2	12/1	8/0.7	5/0.5	4/0.4	
White	1688/157	422/39	270/25	188/17	106/10	68/6	47/4	34/3	
R+G+B+W	2863/266	716/67	458/43	318/30	179/17	115/11	80/7	58/5	

Illuminance distribution

Distance=5m

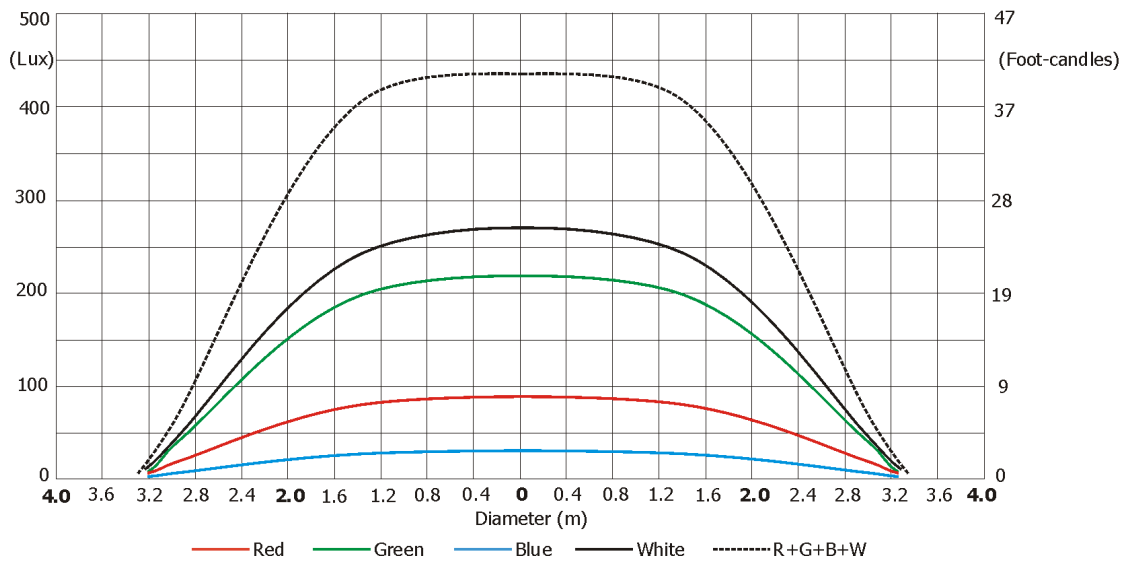

Note: Beam shaper works at min. zoom best

Beam shaper 8°x 26° @ min. zoom

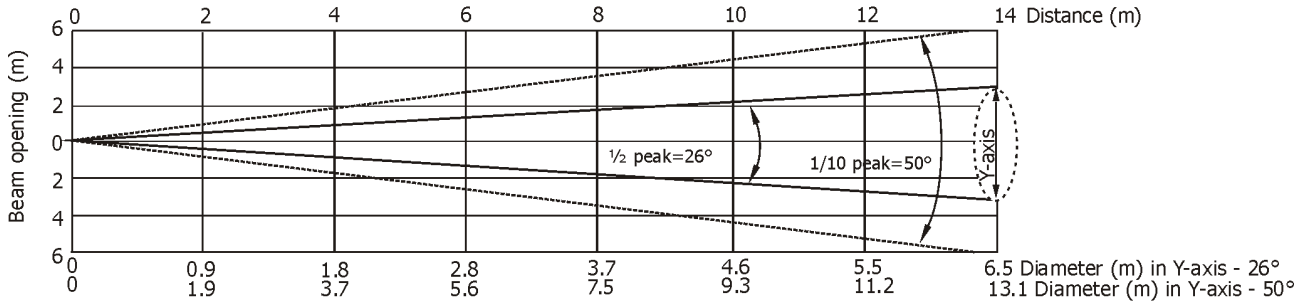
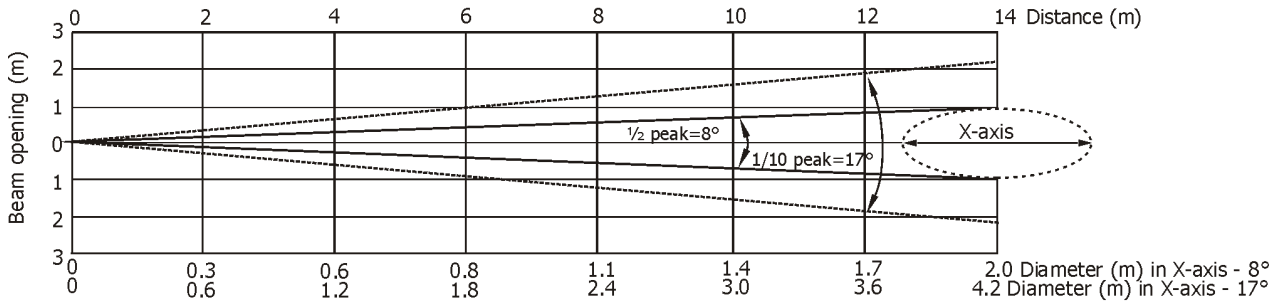

Distance (m)	2	4	6	8	10	12	14	
Red	844/78	210/20	94/9	53/5	34/3	23/2	17/1.6	Intensity (center) Lux/Footcandles
Green	1813/168	453/42	201/19	113/11	73/6.7	50/4.7	37/3.4	
Blue	250/23	63/6	28/2,6	16/1.5	10/0.9	7/0.6	5/0.5	
White	2375/221	594/55	264/25	148/14	95/9	66/6	49/4.5	
R+G+B+W	3875/360	969/90	430/40	242/23	155/14	108/10	79/7	

Illuminance distribution X-axis Distance=5m

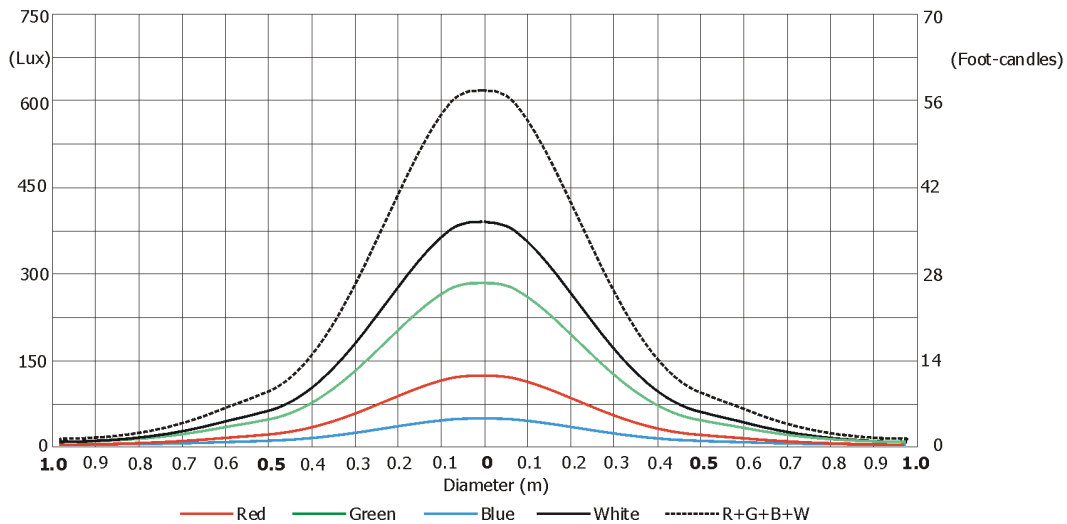

Beam shaper 8°x 26° @ min. zoom

Illuminance distribution Y- axis

Distance=5m

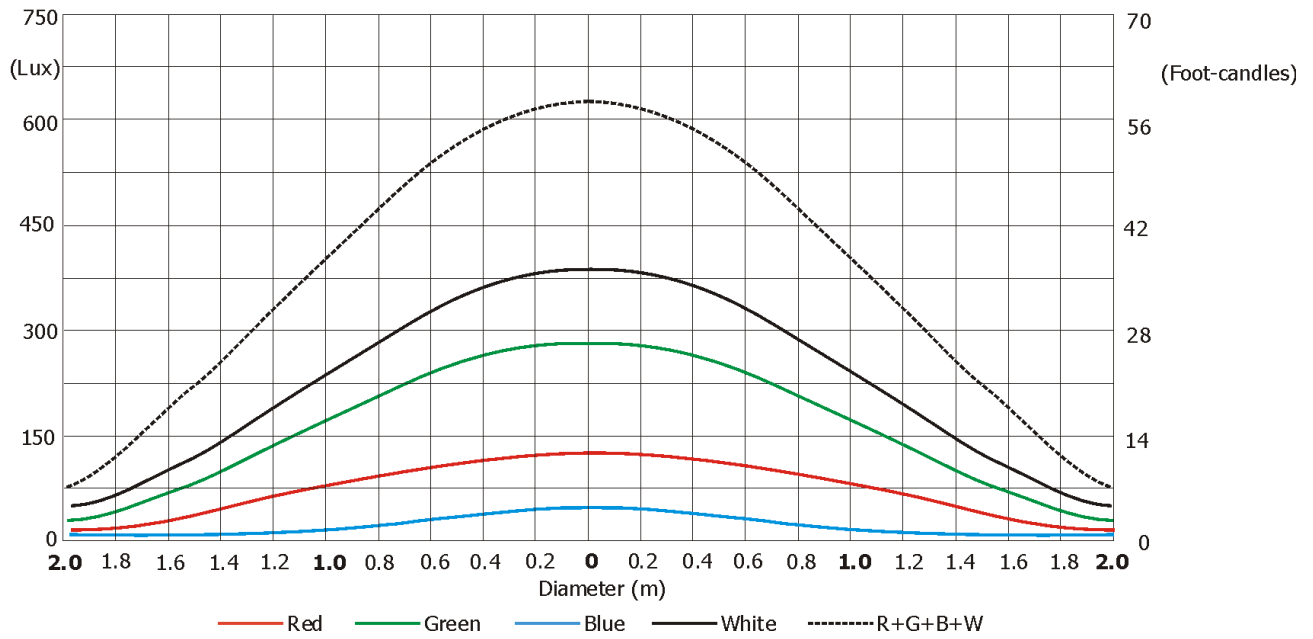

Beam shaper 19°x 35° @ min. zoom

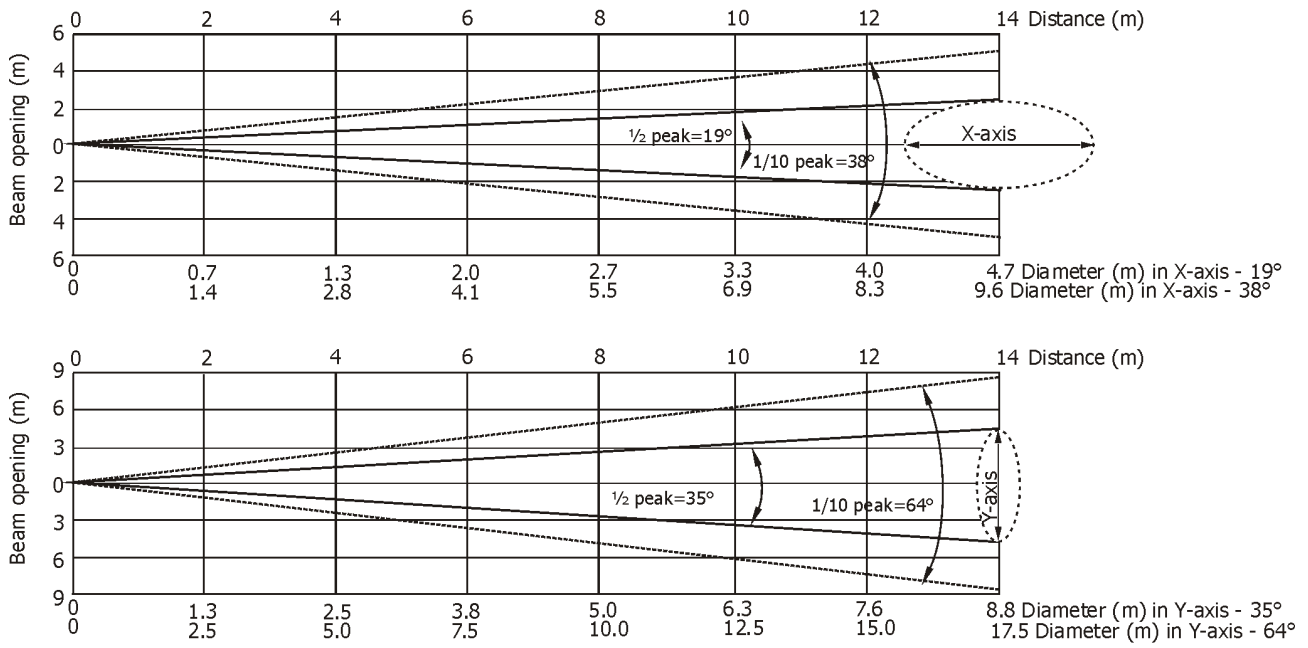

Distance (m)	2	4	6	8	10	12	14	
Red	638/59	159/15	71/7	40/3.7	26/2.4	18/1.6	13/1.2	Intensity (center) Lux/Footcandles
Green	1356/126	339/32	151/14	85/8	54/5	38/3.5	28/2.6	
Blue	188/17	47/4.4	21/2	12/1	8/0.7	5/0.5	4/0.4	
White	1781/166	445/41	198/18	111/10	71/7	50/5	36/3.4	
R+G+B+W	2925/272	731/68	325/30	183/17	117/11	81/8	60/5.5	

Illuminance distribution X-axis

Distance=5m

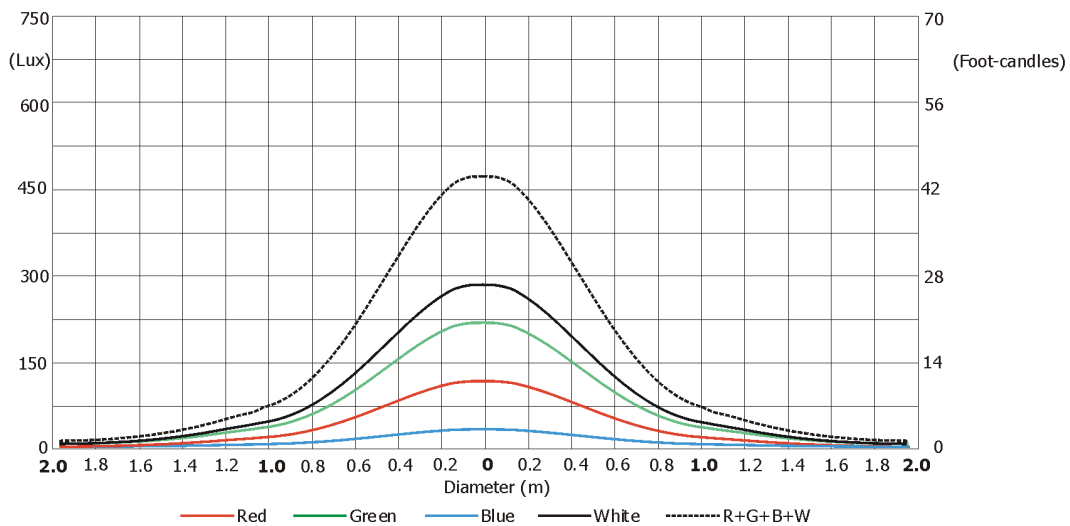

Beam shaper 19°x 35° @ min. zoom

Illuminance distribution Y- axis
Distance=5m

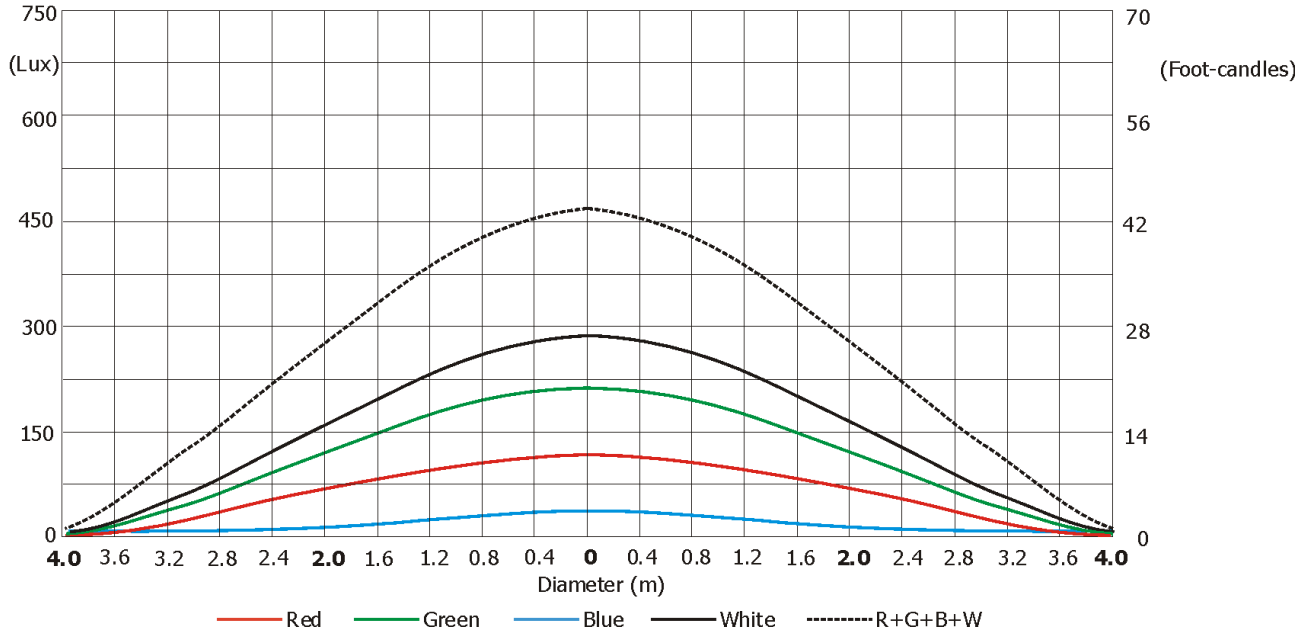

Specifications are subject to change without notice.

April 27, 2018

Copyright © 2012-2018 Robe Lighting - All rights reserved

Made in ROBE Lighting s.r.o., Palackého 416, 757 01 Valašské Meziříčí, Czech Republic

DMX protocol

Robin 800X LEDWash - DMX protocol, version 1.1								
Mode/Channel						Value	Function	Type of control
1	2	3	4	5	6			
1	1	1	1	1	1	0-255	Pan (8 bit) Pan movement by 450° (128=default)	proportional
2	2	2	2	2	2	0-255	Pan Fine (16 bit) Fine control of pan movement (0=default)	proportional
3	3	3	3	3	3	0-255	Tilt (8bit) Tilt movement by 300° (128=default)	proportional
4	4	4	4	4	4	0-255	Tilt fine (16 bit) Fine control of tilt movement (0=default)	proportional
5	5	5	5	5	5	0	Pan/Tilt speed, Pan/Tilt time Standard mode (0=default)	step
						1	Max. speed mode	step
							<i>P./T. speed -set Speed Mode in menu: P./T. Mode</i>	
						2 - 255	Speed from max. to min. (vector mode)	proportional
							<i>P./T. time - set Time Mode in menu: Pan/Tilt Mode</i>	
						2 - 255	Time from 0.2 s to 25.5 s.	proportional
6	6	6	6	6	6		Special functions	
						0 - 9	Reserved (0=default)	
							<i>To activate following functions , stop in DMX value for at least 3sec. and shutter must be closed at least 3sec. (Shutter channel 35/19/14/9/9/22 must be at range of 0-31DMX). Corresponding menu items are temporarily overrided except DMX Input.</i>	
						10-14	DMX input: Wired DMX *	step
						15-19	DMX input: Wireless DMX*	step
							<i>* function is active only10 seconds after switching the fixture on</i>	
						20 - 29	Reserved	
						30-39	Colour mixing mode: RGBW	
						40-49	Colour mixing mode: CMY	
						50 - 59	Pan/Tilt speed mode	step
						60 - 69	Pan/Tilt time mode	step
						70 - 79	Blackout while pan/tilt moving	step
						80 - 89	Disabled blackout while pan/tilt moving	step
						90 - 99	Theatre mode On	step
						100-109	Theatre mode Off	step
						110-114	Zoom mode: Wash	step
						115-119	Zoom mode: Beam	step
						120-124	LEDWash compatibility On	step
						125-129	LEDWash compatibility Off	step
						130-139	Reserved	
							<i>To activate following reset function, stop in DMX value for at least 3 sec.</i>	
						140 - 149	Pan/Tilt reset	step
						150 - 179	Reserved	
						180 - 189	Zoom/Beam shaper reset	step
						190 - 199	Reserved	
						200 - 209	Total reset	step

DMX protocol

Mode/Channel						Value	Function	Type of control
1	2	3	4	5	6			
						210 - 239	Reserved	
						240	Disabled "Quiet mode" of fans <i>To activate "Quiet mode ", stop in range of 241-255 at least 3 sec.</i>	step
						241 - 255	"Quiet mode" of fans: fans noise from min. to max.	proportional
*	7	7	*	*	*		Red/Cyan (8 bit)** - all zones	
						0-255	Colour saturation control - coarse 0-100% (255=default)	proportional
*	8	*	*	*	*		Red/Cyan fine(16 bit)** - all zones	
						0-255	Colour saturation control - fine (255=default)	proportional
*	9	8	*	*	*		Green/Magenta (8 bit)** - all zones	
						0-255	Colour saturation control - coarse 0-100% (255=default)	proportional
*	10	*	*	*	*		Green/Magenta fine (16 bit)** - all zones	
						0-255	Colour saturation control - fine (255=default)	proportional
*	11	9	*	*	*		Blue/Yellow (8 bit)** - all zones	
						0-255	Colour saturation control - coarse 0-100% (255=default)	proportional
*	12	*	*	*	*		Blue/Yelow fine (16 bit)** - all zones	
						0-255	Colour saturation control - fine (255=default)	proportional
*	13	10	*	*	*		White (8 bit) - all zones <i>If RGBW mode is selected:</i>	
						0-255	Colour saturation control - coarse 0-100% (255=default)	proportional
						0-255	<i>If CMY mode is selected:</i> No function	
*	14	*	*	*	*		White fine (16 bit) - all zones	
						0-255	Colour saturation control - fine (255=default)	proportional
7	*	*	*	15	7		Red/Cyan (8 bit)** - zone 1	
						0-255	Colour saturation control - coarse 0-100% (255=default)	proportional
8	*	*	*	16	8		Red/Cyan fine (16 bit)** - zone 1	
						0-255	Colour saturation control - fine (255=default)	proportional
9	*	*	*	17	9		Green/Magenta (8 bit)** - zone 1	
						0-255	Colour saturation control - coarse 0-100% (255=default)	proportional
10	*	*	*	18	10		Green/Magenta fine (16 bit)** - zone 1	
						0-255	Colour saturation control - fine (255=default)	proportional
11	*	*	*	19	11		Blue/Yellow (8 bit)** zone 1	
						0-255	Colour saturation control - coarse 0-100% (255=default)	proportional
12	*	*	*	20	12		Blue/Yellow (16 bit)** zone 1	
						0-255	Colour saturation control - fine (255=default)	proportional
13	*	*	*	21	13		White (8 bit) - zone 1 <i>If RGBW mode is selected:</i>	
						0-255	Colour saturation control - coarse 0-100% (255=default)	proportional
						0-255	<i>If CMY mode is selected:</i> No function	
14	*	*	*	22	14		White (16 bit) - zone 1	
						0-255	Colour saturation control - fine (255=default)	proportional
15	*	*	*	23	15		Red/Cyan (8 bit)** - zone 2	
						0-255	Colour saturation control - coarse 0-100% (255=default)	proportional
16	*	*	*	24	16		Red/Cyan fine (16 bit)** - zone 2	

DMX protocol

Mode/Channel						Value	Function	Type of control
1	2	3	4	5	6			
						0-255	Colour saturation control - fine (255=default)	proportional
17	*	*	*	25	17		Green/Magenta (8 bit)** - zone 2	
						0-255	Colour saturation control - coarse 0-100% (255=default)	proportional
18	*	*	*	26	18		Green/Magenta fine (16 bit)** - zone 2	
						0-255	Colour saturation control - fine (255=default)	proportional
19	*	*	*	27	19		Blue/Yellow (8 bit)** zone 2	
						0-255	Colour saturation control - coarse 0-100% (255=default)	proportional
20	*	*	*	28	20		Blue/Yellow (16 bit)** zone 2	
						0-255	Colour saturation control - fine (255=default)	proportional
21	*	*	*	29	21		White (8 bit) - zone 2	
							<i>If RGBW mode is selected:</i>	
						0-255	Colour saturation control - coarse 0-100% (255=default)	proportional
							<i>If CMY mode is selected:</i>	
						0-255	No function	
22	*	*	*	30	22		White (16 bit) - zone 2	
						0-255	Colour saturation control - fine (255=default)	proportional
23	*	*	*	31	23		Red/Cyan (8 bit)** - zone 3	
						0-255	Colour saturation control - coarse 0-100% (255=default)	proportional
24	*	*	*	32	24		Red/Cyan fine (16 bit)** - zone 3	
						0-255	Colour saturation control - fine (255=default)	proportional
25	*	*	*	33	25		Green/Magenta (8 bit)** - zone 3	
						0-255	Colour saturation control - coarse 0-100% (255=default)	proportional
26	*	*	*	34	26		Green/Magenta fine (16 bit)** - zone 3	
						0-255	Colour saturation control - fine (255=default)	proportional
27	*	*	*	35	27		Blue/Yellow (8 bit)** zone 3	
						0-255	Colour saturation control - coarse 0-100% (255=default)	proportional
28	*	*	*	36	28		Blue/Yellow (16 bit)** zone 3	
						0-255	Colour saturation control - fine (255=default)	proportional
29	*	*	*	37	29		White (8 bit) - zone 3	
							<i>If RGBW mode is selected:</i>	
						0-255	Colour saturation control - coarse 0-100% (255=default)	proportional
							<i>If CMY mode is selected:</i>	
						0-255	No function	
30	*	*	*	38	30		White (16 bit) - zone 3	
						0-255	Colour saturation control - fine (255=default)	proportional
31	15	11	*	13	31		CTC	
						0	No function (0=default)	step
						1-255	Colour temperature correction from 20000K to 2700K (menu item "Colour Calibration Mode"=Off)	proportional
						1-255	Colour temperature correction from 15500K to 2700K (menu item "Colour Calibration Mode"=On)	proportional
32	16	12	7	14	32		Virtual Colour Wheel	
							For detailed description see "Virtual colour wheel- colour mixing chart"	
						0	No function (0=default)	step
						1-2	White 2700 K	step
						3	White 2700 K (Halogen lamp mode***)	step
						4-5	White 3200 K	step
						6	White 3200 K (Halogen lamp mode***)	step

DMX protocol

Mode/Channel						Value	Function	Type of control
1	2	3	4	5	6			
						7-9	White 4200 K	step
						10-12	White 5600 K	step
						13-15	White 8000 K	step
						16	Blue (Blue=full, Red+Green+White=0)	step
						17-55	Red=0, Green->up, Blue =full, White=0	proportional
						56	Light Blue (Red=0, Green=full, Blue =full, White=0)	step
						57 - 95	Red=0, Green=full, Blue->down, White=0	proportional
						96	Green (Red=0, Green=full, Blue =0, White=0)	step
						97 – 134	Red->up, Green=full, Blue=0, White=0	proportional
						135	Yellow (Red=full, Green=full, Blue=0, White=0)	step
						136 - 174	Red=full, Green->down, Blue=0, White=0	proportional
						175	Red(Red=full, Green=0, Blue=0, White=0)	step
						176 -214	Red=full, Green=0, Blue->up, White=0	proportional
						215	Magenta (Red=full, Green=0, Blue=full, White=0)	step
						216 - 246	Red -> down, Green=0, Blue=full, White=0	proportional
						247	Blue (Red=0, Green=0, Blue=full, White=0)	step
							<i>Speed of the following effects can be controlled by the Shutter/Strobe channel (DMX values of 96-127)</i>	
						248	Rainbow effect (with fade time)	step
						249	Rainbow effect	step
						250	Zone effect 1	step
						251	Zone effect 2	step
						252	Zone effect 3	step
						253	Zone effect 4	step
						254	Zone effect 5	step
						255	Zone effect 6	step
33	17	13	8	9	*		Beam shaper	
						0-127	Beam shaper indexing 0°-180° (0=default)	proportional
						128-191	Forwards rotation from fast to slow	proportional
						192-255	Backwards rotation from slow to fast	proportional
34	18	14	9	7	33		Zoom (8 bit)	
						0 - 255	Zoom from min. to max. beam angle (128=default)	proportional
35	19	*	*	8	34		Zoom fine (16 bit)	
						0 - 255	Fine zooming from min. to max. (0=default)	proportional
36	20	15	10	10	35		Shutter/Strobe	
						0-31	Shutter closed	step
						32-63	Strobe effect from slow--> fast (zone 3 only) (32=default)	proportional
						64-95	Strobe effect from slow--> fast (All zones together)	proportional
							<i>Set value on Virtual colour wheel for zone effects</i>	
						96-111	Zone effects+rainbow effects speed control, slow--> fast	proportional
						112-127	Zone effects+rainbow effects speed control, fast--> slow /opposite direction/	proportional
						128-143	Opening pulses in sequences from slow--> fast (All zones together)	proportional
						144-159	Closing pulses in sequences from fast--> slow (All zones together)	proportional
						160-175	Random strobe effect from slow--> fast (random zone)	proportional

DMX protocol

Mode/Channel						Value	Function	Type of control
1	2	3	4	5	6			
						176-191	Random strobe effect from slow--> fast (random zone + random strobe)	proportional
						192-223	Random strobe effect from slow --> fast (All zones together)	proportional
						224-255	Shutter open	step
37	21	16	11	11	36		Dimmer (8 bit)	
						0-255	Dimmer intensity from 0% to 100% (0=default)	proportional
38	22	*	*	12	37		Dimmer fine (16 bit)	
						0-255	Fine dimming (0=default)	proportional
**Select RGB or CMY mixing mode on channel "Power/Special functions" .								
*** Halogen lamp effect is simulated during dimming								
Copyright © 2020 Robe Lighting s.r.o. - All rights reserved								
All Specifications subject to change without notice								

Robin 800X LEDWash - Virtual Colour Wheel

Scale*	Virtual Colour Wheel DMX	Red DMX	Green DMX	Blue DMX	White DMX
	1-2 (White 2700K)	255	158	0	53
	3 (White 2700K /Hal.mode/)	255	158	0	53
	4-5 (White 3200K)	255	173	0	102
	6 (White 3200K /Hal.mode/)	255	173	0	102
	7-9 (White 4200K)	255	197	0	255
	10-12 (White 5600K)	233	255	35	255
	13-15 (White 8000K)	162	255	63	255
	16	0	0	255	0
	17	0	3	255	0
	18	0	6	255	0
	19	0	9	255	0
	20	0	12	255	0
	21	0	15	255	0
	22	0	18	255	0
	23	0	21	255	0
	24	0	24	255	0
	25	0	27	255	0
	26	0	30	255	0
	27	0	36	255	0
	28	0	41	255	0
	29	0	46	255	0
	30	0	52	255	0
	31	0	58	255	0
	32	0	64	255	0
	33	0	68	255	0
	34	0	74	255	0
	35	0	80	255	0
	36	0	86	255	0
	37	0	92	255	0
	38	0	98	255	0
	39	0	104	255	0
	40	0	110	255	0
	41	0	119	255	0
	42	0	129	255	0
	43	0	138	255	0
	44	0	147	255	0
	45	0	156	255	0
	46	0	165	255	0
	47	0	174	255	0
	48	0	183	255	0
	49	0	192	255	0
	50	0	201	255	0
	51	0	210	255	0
	52	0	219	255	0
	53	0	228	255	0
	54	0	237	255	0
	55	0	246	255	0
	56	0	255	255	0
	57	0	255	246	0
	58	0	255	237	0
	59	0	255	228	0
	60	0	255	219	0
	61	0	255	210	0
	62	0	255	201	0
	63	0	255	192	0

Robin 800X LEDWash - Virtual Colour Wheel

Scale*	Virtual Colour Wheel	Red	Green	Blue	White
	DMX	DMX	DMX	DMX	DMX
	64	0	255	183	0
	65	0	255	174	0
	66	0	255	165	0
	67	0	255	156	0
	68	0	255	147	0
	69	0	255	138	0
	70	0	255	129	0
	71	0	255	119	0
	72	0	255	110	0
	73	0	255	104	0
	74	0	255	98	0
	75	0	255	92	0
	76	0	255	86	0
	77	0	255	80	0
	78	0	255	74	0
	79	0	255	68	0
	80	0	255	64	0
	81	0	255	58	0
	82	0	255	52	0
	83	0	255	46	0
	84	0	255	41	0
	82	0	255	36	0
	86	0	255	30	0
	87	0	255	27	0
	88	0	255	24	0
	89	0	255	21	0
	90	0	255	18	0
	91	0	255	15	0
	92	0	255	12	0
	93	0	255	9	0
	94	0	255	6	0
	95	0	255	3	0
	96	0	255	0	0
	97	3	255	0	0
	98	6	255	0	0
	99	9	255	0	0
	100	12	255	0	0
	101	15	255	0	0
	102	18	255	0	0
	103	21	255	0	0
	104	24	255	0	0
	105	27	255	0	0
	106	30	255	0	0
	107	36	255	0	0
	108	41	255	0	0
	109	46	255	0	0
	110	52	255	0	0
	111	58	255	0	0
	112	64	255	0	0
	113	68	255	0	0
	114	74	255	0	0
	115	80	255	0	0
	116	86	255	0	0
	117	92	255	0	0
	118	98	255	0	0

Robin 800X LEDWash - Virtual Colour Wheel

Scale*	Virtual Colour Wheel	Red	Green	Blue	White
	DMX	DMX	DMX	DMX	DMX
	119	104	255	0	0
	120	110	255	0	0
	121	119	255	0	0
	122	129	255	0	0
	123	138	255	0	0
	124	147	255	0	0
	125	156	255	0	0
	126	165	255	0	0
	127	174	255	0	0
	128	183	255	0	0
	129	192	255	0	0
	130	201	255	0	0
	131	210	255	0	0
	132	219	255	0	0
	133	228	255	0	0
	134	240	255	0	0
	135	255	255	0	0
	136	255	246	0	0
	137	255	237	0	0
	138	255	228	0	0
	139	255	219	0	0
	140	255	210	0	0
	141	255	201	0	0
	142	255	192	0	0
	143	255	183	0	0
	144	255	174	0	0
	145	255	165	0	0
	146	255	156	0	0
	147	255	147	0	0
	148	255	138	0	0
	149	255	129	0	0
	150	255	119	0	0
	151	255	110	0	0
	152	255	104	0	0
	153	255	98	0	0
	154	255	92	0	0
	155	255	86	0	0
	156	255	80	0	0
	157	255	74	0	0
	158	255	68	0	0
	159	255	64	0	0
	160	255	58	0	0
	161	255	52	0	0
	162	255	46	0	0
	163	255	41	0	0
	164	255	36	0	0
	165	255	30	0	0
	166	255	27	0	0
	167	255	24	0	0
	168	255	21	0	0
	169	255	18	0	0
	170	255	15	0	0
	171	255	12	0	0
	172	255	9	0	0
	173	255	6	0	0

Robin 800X LEDWash - Virtual Colour Wheel

Scale*	Virtual Colour Wheel	Red	Green	Blue	White
	DMX	DMX	DMX	DMX	DMX
	174	255	3	0	0
	175	255	0	0	0
	176	255	0	3	0
	177	255	0	6	0
	178	255	0	9	0
	179	255	0	12	0
	180	255	0	15	0
	181	255	0	18	0
	182	255	0	21	0
	183	255	0	24	0
	184	255	0	27	0
	185	255	0	30	0
	186	255	0	36	0
	187	255	0	41	0
	188	255	0	46	0
	189	255	0	52	0
	190	255	0	58	0
	191	255	0	64	0
	192	255	0	68	0
	193	255	0	74	0
	194	255	0	80	0
	195	255	0	86	0
	196	255	0	92	0
	197	255	0	98	0
	198	255	0	104	0
	199	255	0	110	0
	200	255	0	119	0
	201	255	0	129	0
	202	255	0	138	0
	203	255	0	147	0
	204	255	0	156	0
	205	255	0	165	0
	206	255	0	174	0
	207	255	0	183	0
	208	255	0	192	0
	209	255	0	201	0
	210	255	0	210	0
	211	255	0	219	0
	212	255	0	228	0
	213	255	0	237	0
	214	255	0	246	0
	215	255	0	255	0
	216	246	0	255	0
	217	237	0	255	0
	218	228	0	255	0
	219	219	0	255	0
	220	210	0	255	0
	221	201	0	255	0
	222	192	0	255	0
	223	183	0	255	0
	224	174	0	255	0
	225	165	0	255	0
	226	156	0	255	0
	227	147	0	255	0
	228	138	0	255	0

Robin 800X LEDWash - Virtual Colour Wheel

Scale*	Virtual Colour Wheel	Red	Green	Blue	White
	DMX	DMX	DMX	DMX	DMX
	229	129	0	255	0
	230	119	0	255	0
	231	110	0	255	0
	232	104	0	255	0
	233	98	0	255	0
	234	91	0	255	0
	235	84	0	255	0
	236	77	0	255	0
	237	70	0	255	0
	238	63	0	255	0
	239	56	0	255	0
	240	49	0	255	0
	241	42	0	255	0
	242	35	0	255	0
	243	28	0	255	0
	244	21	0	255	0
	245	14	0	255	0
	246	7	0	255	0
	247	0	0	255	0
	248-255 (Rainbow+ zone effects)	****	****	****	****
* Colour scale as an illustration only					

