



CONTROL SYSTEMS



12 Channel Rack Mount



6 Channel Rack Mount



12 Channel Wall Mount



6 Channel Wall Mount



12 Channel Wall Mount
Hardwired



6 Channel Wall Mount
Hardwired

APSX

Advanced Power System

User Manual

LSC Control Systems ©
+61 3 9702 8000
info@lsccontrol.com.au
www.lsccontrol.com.au



V5.00
November 2025

Disclaimer

LSC Control Systems Pty Ltd has a corporate policy of continuous improvement, covering areas such as product design and documentation. To achieve this goal, we undertake to release software updates for all products on a regular basis. In light of this policy, some detail contained in this manual may not match the exact operation of your product. Information contained in this manual is subject to change without notice.

In any event, LSC Control Systems Pty Ltd cannot be held liable for any direct, indirect, special, incidental, or consequential damages or loss whatsoever (including, without limitation, damages for loss of profits, business interruption, or other pecuniary loss) arising out of the use or the inability to use this product for its intended purpose as expressed by the manufacturer and in conjunction with this manual.

Servicing of this product is recommended to be carried out by LSC Control Systems Pty Ltd or its authorised service agents. No liability will be accepted whatsoever for any loss or damage caused by service, maintenance or repair by unauthorised personnel. In addition, servicing by unauthorised personnel may void your warranty.

LSC Control Systems' products must only be used for the purpose for which they were intended.

Whilst every care is taken in the preparation of this manual, LSC Control Systems takes no responsibility for any errors or omissions.

Copyright Notices

"LSC Control Systems" is a registered trademark.

lsccontrol.com.au is owned and operated by LSC Control Systems Pty Ltd.

All Trademarks referred to in this manual are the registered names of their respective owners.

The operating software of the APSX and the contents of this manual are copyright of LSC Control Systems Pty Ltd © 2021.

All rights reserved.

Contact Details

LSC Control Systems Pty Ltd

ABN 21 090 801 675

65-67 Discovery Road
Dandenong South, Victoria 3175 Australia
Tel: +61 3 9702 8000

email: info@lsccontrol.com.au

web: www.lsccontrol.com.au

Contents

1	Introduction.....	5
1.1	About this Manual.....	5
1.1.1	Conventions Used in this Manual	5
1.2	Overview and Features.....	5
1.3	Models/Options.....	7
1.3.1	Rackmount APSX.....	7
1.3.2	Wallmount APSX.....	7
2	Quick Start Guide.....	8
2.1	APS Channel Switching.....	9
2.1.1	Stopping Automatic Shutdown.....	9
3	Installation	10
3.1	Safety.....	10
3.2	Unpacking	10
3.3	Mounting the APSX	10
3.3.1	Rackmount APSX.....	10
3.3.2	Wallmount APSX.....	10
3.4	Connections	12
3.4.1	Input Power Supply	12
3.4.2	DMX Input (and GPI).....	12
3.4.3	DMX Thru (and GPO).....	12
3.4.4	Ethernet.....	13
3.5	Power Outputs and Phasing	13
4	Front Panel	14
5	Configuration and Operation	15
5.1	Overview	15
5.2	Help Screens.....	16
5.3	Operating Modes.....	16
5.4	Configuration Menu	17
5.5	Chan Config	17
5.5.1	Set To DMX.....	18
5.5.2	Set to Off.....	19
5.5.3	Set To On.....	19
5.5.4	Set To APS.....	19
5.5.5	Set To OSC.....	21
5.6	Timing	22
5.6.1	Stagger Power On.....	22
5.6.2	Power Off Delay	22

5.6.3	Warning Beep.....	23
5.7	Stand Alone.....	23
5.8	Manual Mode.....	24
5.9	RDM Control.....	24
5.10	Emergency Mode.....	24
5.11	System.....	25
5.11.1	Voltage Limits.....	25
5.11.2	Reset.....	26
5.11.3	Service	26
5.11.4	Fan Control.....	27
5.11.5	Colour Theme.....	27
5.11.6	Network	27
5.11.7	Control Source.	28
5.12	About	28
5.12.1	Owner.....	28
5.13	Lock / Unlock	29
5.14	Software Update	30
6	Control Protocols	32
6.1	DMX.....	32
6.2	ArtNet.....	32
6.3	sACN.....	32
6.4	RDM.....	32
6.4.1	ArtRdm	33
6.5	APSX RDM Commands.....	33
7	HOUSTON X.....	34
8	Maintenance and Troubleshooting.....	34
8.1	Maintenance.....	34
8.2	Tripped Breakers.....	34
9	Specifications and Output Options	35
9.1	Rackmount APSX.....	35
9.2	Wallmount APSX.....	36
9.3	Wieland Pinouts.....	38
9.4	Socapex Pinouts.....	38
10	Feature History.....	39
11	Compliance Statements	39

1 Introduction

1.1 About this Manual

This manual describes the installation, configuration and operation of the APSX (Advanced Power System) intelligent power distribution unit manufactured by LSC Control Systems.

There are four different colour themes that you can select on the APSX touch screen. The screen images in this manual use the default “Gothic” colour theme.

1.1.1 Conventions Used in this Manual

Throughout this manual, certain conventions have been used to make the meaning clearer.

- A word in **Bold** text represents a virtual button on the press screen.
- Emphasis is indicated by underlining.
- *Notes or Hints are displayed in italic font*

1.2 Overview and Features

The APSX (Advanced Power System with Ethernet) is a power switching and distribution unit with a 3 phase mains input (single phase input available) and either 6 or 12 single phase switched outputs depending upon the model.

Being a power control and distribution unit, the APSX is equally at home in a variety of permanent and touring applications including (but certainly not limited to),

- Moving Lights
- LED fixtures
- Video walls
- Audio Systems
- Stall power for Markets and Fairgrounds

Power Distribution is the most critical components of any system and lighting is no exception particularly these days when almost every fixture now needs its own mains power source. However, with each fixture needing power, new problems are introduced particularly during the power up sequence.

Firstly, in-rush currents of all the power supplies and lamps starting up at the same time often causes main breakers to trip and secondly the transient currents drawn by the power supplies can cause earth protection breakers to trip. To avoid these effects, you require complicated power up sequences usually requiring a human sitting there switching circuits on one at a time.

The APSX units are a solution to this and other problems by using internal relays to switch the power and controlling the power-on sequence of each of the individual output circuits. In its simplest form, a single command starts the sequence and then each of the 12 outputs is turned on, one output at a time, with a programmable time before the next circuit turns on. In this way the peak current drawn is always low and upstream breakers should not trip.

In addition, nuisance circuit breaker tripping is overcome by the APSX by switching on the relay as the mains voltage passes through the zero point of the sine wave, thus providing a pseudo soft-start.

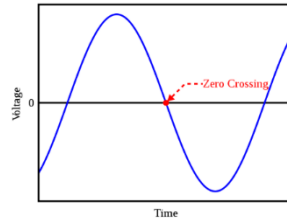

APSX units can be connected together where more than 12 circuits are required and the units automatically cascade. That is, the second unit won't commence its start-up sequence until the first has finished.

One of the potentially most expensive faults that you might encounter is a “dropped” Neutral on the mains supply. If you connect your video, lighting or audio rig to power and turn it on and the Neutral is missing, you can potentially get 415V across all connected devices and the result can be catastrophic. The APSX internal electronics are designed to run at 415V without causing damage so they can tolerate a missing neutral. When the APSX powers up, it does not energise any of the outputs until it has measured the voltages on all phases and checked they are within safe working limits. If they are not, then it will not switch on the outputs (no matter what you tell it to do) and instead displays a large error message. Similarly, if the Neutral fails mid show, then the APSX will disconnect power within 50mS, therefore minimising damage to attached equipment.

The APSX measures both incoming voltage and frequency and uses this information to delay the power-up sequence until they have stabilised. This is of particular importance if your power is being supplied from a generator. In addition, because the loads are sequentially switched on, there is no sudden large load presented to the generator which increases the stability of the generator output.

The APSX is also ideal for permanent installations such as schools, churches, public halls and other venues where Energy Management is a key goal. By using the “APSX” mode to power all the lighting and video system, the lighting and video equipment will be automatically and sequentially powered up over a few seconds when the lighting console is turned on (and the control signal is detected) without any user intervention. At the end of the session, after the lighting console is turned off all the LED fixtures, video screens and moving lights will automatically be switched off after an adjustable delay time. A truly green solution.

The APSX includes the following features:

- Automatic control via DMX512, sACN or ArtNet. The presence of the selected control signal sequentially turns outputs on and loss of control signal turns outputs off after a pre-set time delay.
- Remote GPI contact closure (if control signal is not used) sequentially turns outputs on and open contact turns outputs off after a pre-set time delay.
- Remote On/Off switching of individual output circuits via DMX512, sACN, ArtNet or OSC (Open Sound Control).
- “Stand Alone” mode for automatic On/Off of output circuits whenever input power is present.
- Manual override (On/Off of output circuits) via front panel touch screen (with user lock out).
- Control via RDM.
- Control and monitoring via Houston X.
- RCBO (Residual Current Breaker with Overcurrent) output channel circuit breakers protect against current overload AND earth leakage faults. Also known as RCD (Residual Current Device) or GFI (Ground Fault Indicator).

- RCBO output channel circuit breakers also provide Neutral Disconnect function.
- Staggered switch on of outputs (with adjustable delay) to prevent start-up surge overloading of the power supply feed.
- Multiple APSX units can be configured to start up in sequence.
- Cascading start-up for individual units via XLR5 cabling and/or based on unit number.
- Input voltage monitoring (RMS) per phase with over voltage switch off.
- Input current monitoring (RMS) per phase.
- Dropped neutral protection with almost instant load disconnect.
- Input mains frequency monitoring.
- Programmable over-voltage and under-voltage trips to protect loads. Voltage and current reporting via RDM.
- Three phase operation.
- Single phase operation possible but input current must be limited to 63A in total.

1.3 Models/Options

1.3.1 Rackmount APSX

The Rackmount APSX is available in the following sizes,

- 12 channels x 10 Amp outputs
- 12 channels x 16 Amp outputs (export only)
- 6 channels x 25 Amp outputs

Output connection options,

- Australian sockets
- Weiland sockets
- Socapex sockets
- CEE7 (Shuko) sockets
- Powercon connectors (2 variants available)
- Terminals (for permanent installations)
- Socapex sockets plus 3 “powerCon True1Top” connectors in parallel with channels 1-3 of the Socapex. This combination of outputs is designed for video wall users who can power the video screen panels via the Socapex outputs but also have 3 powerCon connectors for media servers, ethernet switches, etc, all protected by the APSX.

See section 9.1 for details on input and output connection options.

1.3.2 Wallmount APSX

The Wallmount APSX is available in the following sizes,

- 12 channels x 13 Amp outputs
- 6 channels x 25 Amp outputs

Output connection options,

- Front panel 12 X 15 Amp Australian GPO outlets
- Front panel 6 X paired (20A + 15A per channel) Australian GPO outlets
- Internal terminals (for permanent installations)

See section 9 for details on input and output connection options.

2 Quick Start Guide

Every output channel can be individually configured to operate in any of the following modes:

- **APS.** The channels are sequentially switched on when triggered. There are several methods of triggering the “switch on” sequence as described below.
- **DMX.** The channel is switched by the level of the DMX slot (address) of the selected control source to which it is patched. This is the equivalent of a DMX controlled switch. The control source can be either DMX, sACN or ArtNet. See section 5.5.1
- **OFF.** Always Off.
- **ON.** Always On.
- **OSC.** The channel is switched by an OSC command via the Ethernet input. See section 5.5.5

To change the configuration of a channel, press anywhere on the **home screen** to reveal the “Configuration Menu” then press **Chan Config**.

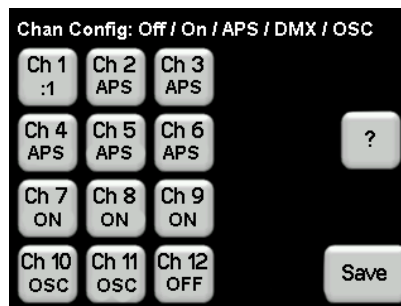

Each channel button shows its current configuration setting. Channels set to DMX show the DMX slot number to which they are patched.

Select the channels to configure by pressing their numbers. Selected channels turn dark grey. When any channel has been selected the “Config” button appears. For example, if channels 1 and 2 were selected....

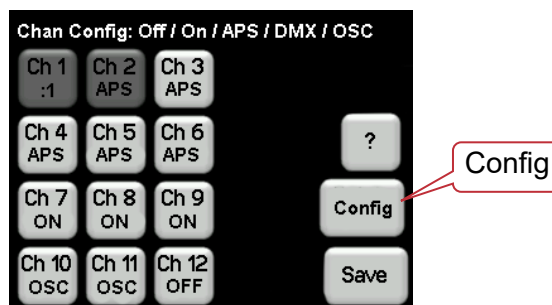

Press **Config**,

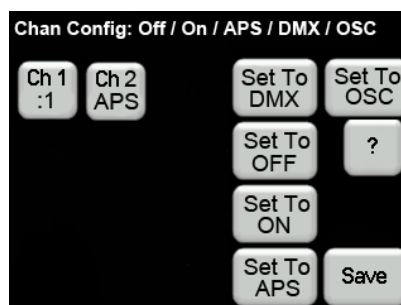

Press the desired configuration for the selected channel(s) then press **Save**.

2.1 APS Channel Switching

All channels set to APS can be sequentially switched on via any of the following methods.

- Control signal presence. The APSX will start its staggered switch on sequence of channels that are set to “APS” whenever the selected control signal is detected. In this mode, the APSX does not use a DMX slot (address) and is not controlled by DMX levels. It only responds to the presence or absence of a valid selected control signal. When the selected control signal is no longer present (when the lighting controller is switched off) the APSX will switch off all channels after the adjustable “Power Off Delay” time. To select a control source for the APSX, press anywhere on the **Home Screen** then **Config, Control Source**. The choices are: ArtNet, sACN, DMX.
- GPI (General Purpose Input). The APSX will start its staggered switch on sequence of channels that are set to “APS” when a contact closure is detected on the GPI connector. See 5.5.4.2
- Standalone mode. The APSX will start its staggered switch on sequence of channels that are set to “APS” mode 3 seconds after power is applied at the input. To select “stand alone” mode, press anywhere on the **Home Screen** then **Stand Alone, Enable**.
- Manual Mode. If the APS controlled outputs are OFF, press anywhere on the **Home Screen**, then **Manual APS On**. This starts the switch-on sequence of “APS” channels. If the APS controlled outputs are ON, pressing anywhere on the **Home Screen** then **Manual APS Off** switches off all “APS” channels after you say “yes” to a confirmation warning. See 5.8

2.1.1 Stopping Automatic Shutdown

If the APSX about to turn off and you want to keep it on, press the screen to postpone the shutdown countdown then press anywhere on the **Home Screen** then press **Stand Alone**, then **Enable**.

3 Installation

3.1 Safety

All electrical work must be carried out by suitably qualified persons.

3.2 Unpacking

The APSX is fully tested and inspected before leaving the factory. Upon delivery, inspect the APSX for signs of damage or mishandling. In the event of any damage, contact your LSC agent.

3.3 Mounting the APSX

3.3.1 Rackmount APSX

The Rackmount APSX is designed for mounting in a standard 19 inch rack. It occupies 3RU (Rack Units) of space.

3.3.2 Wallmount APSX

The wall-mount version is comprised of two sections. The front section (containing all of the electronics) is attached to the rear section by two hinges located at the bottom and the front section can be completely detached from the rear section to allow better access to the mounting points and the supply and load cable terminations. This also allows the rear section to be mounted and connected whilst the front section is safely stored until all other trades have completed their work and the area is safe and clean.

The front section can be opened by removing the 4 large screws as indicated below.



To completely detach the front section, remove the 4 large screws as shown then unfold the front section. Use a 10mm spanner to remove the 2 nuts holding the metal support straps and lift the straps off the bolts. Replace the nuts to retain the fibre washers. Carefully unfold the front section to the fully open position.

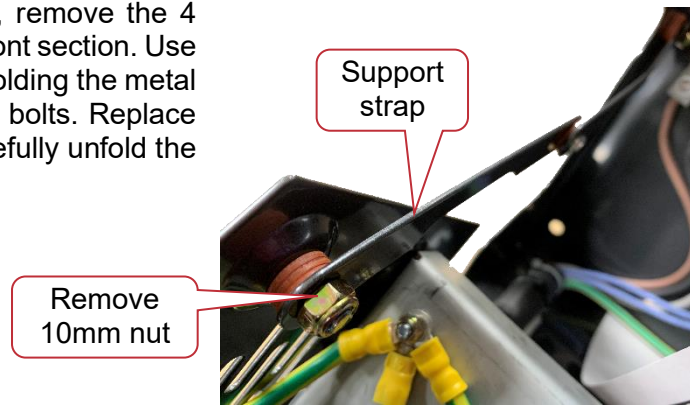

Disconnect the 3-phase cable to the front section from the input terminal block on the rear section and un-bolt the earth connection. Cut the cable tie that secures the 3-phase input cable

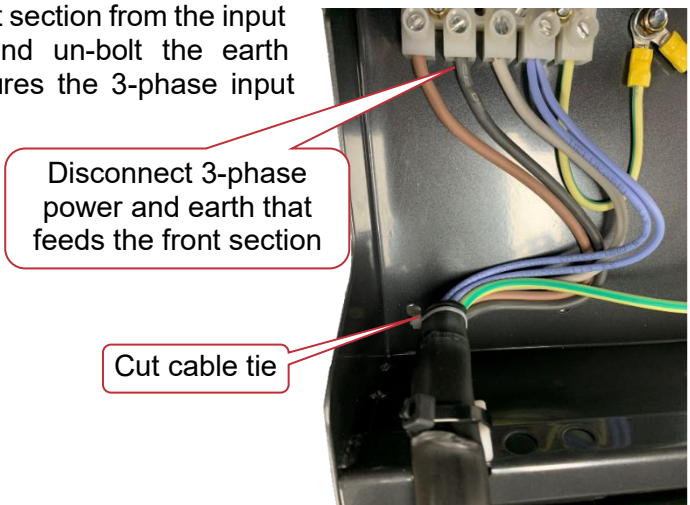

For hardwired output versions only

10-Amp output versions

Un-plug the load connector plugs from the load terminal blocks on the rear section. These connections are tight and will need to be prised out.

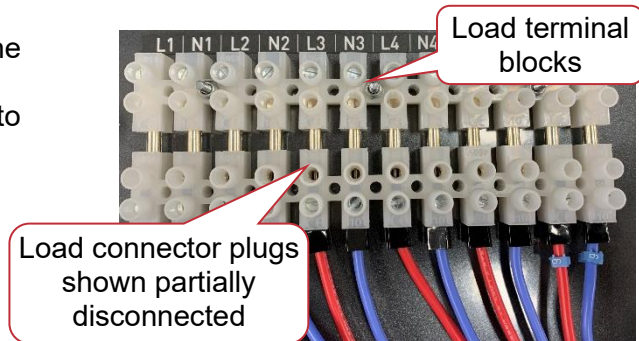

25-Amp output versions

Remove the load terminal block by undoing the nuts that secure the terminal block to the rear section.

The front section can now be removed from the rear section by sliding it sideways off the split hinges.

The rear section has provisions for mounting to walls and other upright structures such as uni-strut. Mounting brackets for P1000 Uni-Strut are available from LSC.

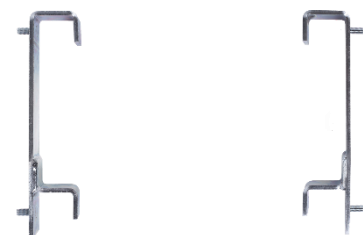

Uni-Strut brackets

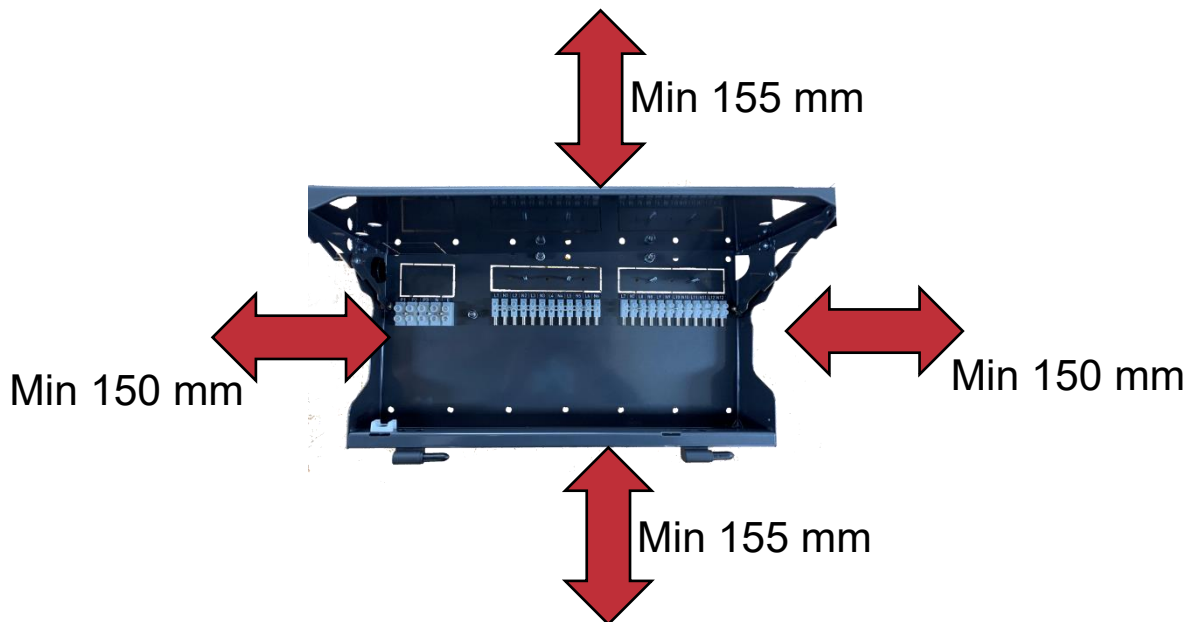

APSX Wall Mount Rear Section

Allow a minimum of 150mm clearance on either side and 155mm vertical clearance to allow units above and below to be opened.

The wall mount APSX weighs 16Kgm.

3.4 Connections

3.4.1 Input Power Supply

The APSX must be fed from a suitable external circuit breaker.

The nominal input voltage is 220-240 Volts. 3-phase Star (380-415V). 50-60Hz. Single phase operation is possible but input current must be limited to 63A in total.

3.4.2 DMX Input (and GPI)

A 5 pin XLR is provided for DMX input. Two modes of DMX operation are possible.

- DMX Presence. The switch on sequence is started whenever DMX is detected on the DMX input.
- DMX Control. Channels set to "DMX" are controlled by the DMX level of the DMX slot to which they are patched.

See section 5.5.1

The DMX Input connector is also used for a GPI (General Purpose Input). If DMX is not being used to automatically control an APSX, then the APSX can be remotely switched on (starting its standard switch-on sequence) by providing a contact closure between pins 1 and 4 of the DMX Input connector. When the contact closure is opened, the APSX will switch off all channels after the adjustable delay time

3.4.3 DMX Thru (and GPO)

A 5 pin XLR is provided for DMX Thru (output). The DMX Thru connector is primarily provided to feed the DMX signal to another APSX unit. The APSX will automatically connect the DMX input to the DMX Thru at the completion on the switch on sequence when all 12 outputs have been switched on. This provides an automatic method of sequentially switching on multiple APSX units.

When the outputs of an APSX are switched off (either automatically by the loss of DMX or manually via the press screen) the feed of DMX to the DMX Thru connector is also switched off.

The DMX Thru connector is also used as a GPI output. This is provided to feed a GPI signal to another APSX unit. The APSX will automatically provide a contact closure between pins 1 and 4 of the DMX Thru connector at the completion on its switch on sequence (when all 12 outputs have been switched on). If the GPI output is connected to the GPI input of the next APSX, then multiple APSX units can be sequentially controlled by a single switch connected to the first APSX.

When the outputs of an APSX are switched off, the contact closure on the DMX Thru connector is also switched off. This will therefore automatically switch off any APSX connected to the DMX Thru (GPI output).

3.4.4 Ethernet

An RJ45 Ethernet connector is provided. You can use this connection for control using sACN, Art-Net, OSC and to connect a computer running LSC’s HOUSTON X software that is used for configuration, monitoring and software upgrades.

A green “Activity” LED below the Ethernet connector indicates when data is present.

3.5 Power Outputs and Phasing

The outputs are fed from the following input power phases.

Output	Input Phase
1	1
2	2
3	3
4	1
5	2
6	3
7	1
8	2
9	3
10	1
11	2
12	3

The input phase number for each output is also shown on the front panel below each output circuit breaker.

The output connections and the pin-outs of the multi-pin sockets are listed in section 9.

4 Front Panel

The front panel contains the RCBO (Residual Current Breaker with Overcurrent) circuit breakers for each output. The number below each circuit breaker shows which input phase feeds that output channel.

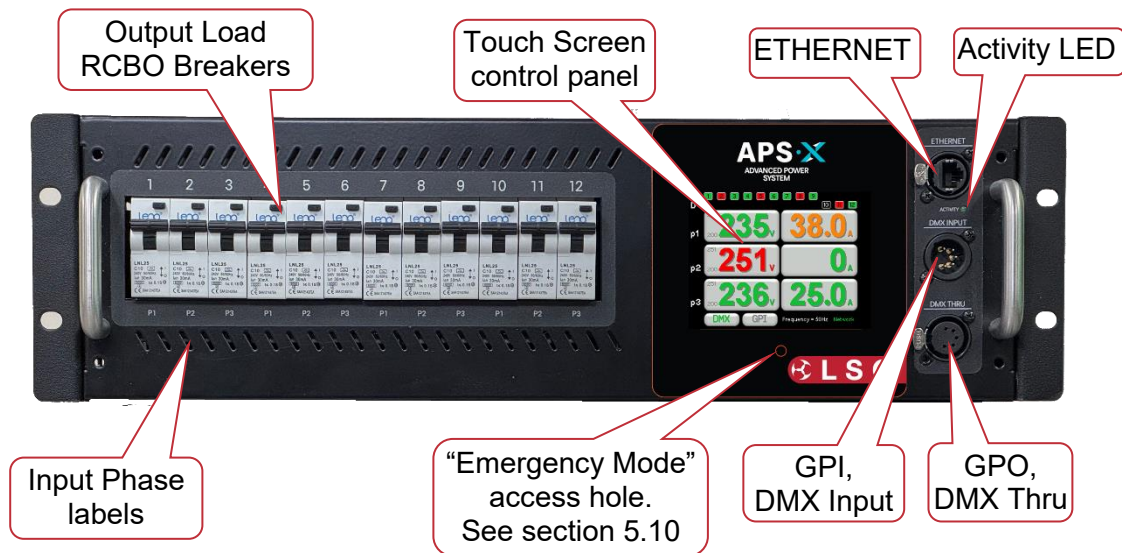

Rackmount APSX

The wall mount APSX has the ETHERNET, GPI/DMX INPUT and GPO/DMX THRU connectors located on the right side of the cabinet.

5 Configuration and Operation

5.1 Overview

The APSX uses a colour LCD touch screen which is operated by pressing the virtual buttons with your finger or a stylus. Do not use sharp objects to operate the touch screen.

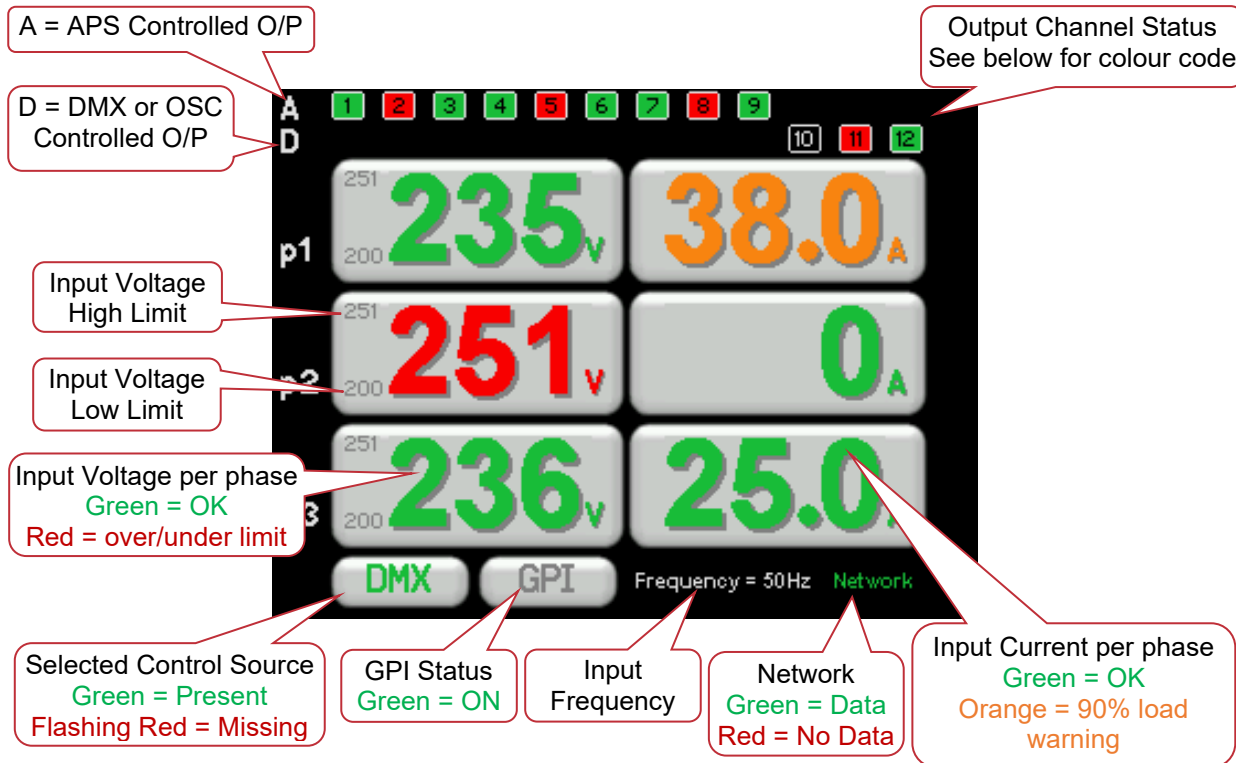

Home Screen

Touch anywhere on the “Home Screen” to access the “Configuration Menu”.

The output channel status icons at the top of the home screen have two rows, A and D.

- Channels in the “A” row are controlled by the APSX. See section 5.5.4
- Channels in the “D” row are controlled by the DMX slot of the control source to which they are patched. See section 5.5.1. The control source can be either DMX, sACN or ArtNet. See section 5.5.1. Channels controlled by OSC are also shown in the “D” row. See section 5.5.5.

The output channel status icons also show the current status of each output.

- **Green** = The channel is on via APSX control or Input Signal control
- **Black** = The channels is off via APSX control or Input Signal control.
- **Blue** = The channel is always on
- **X** = The channel is always off
- **Red** = The channel has been automatically turned “Off” due to an over or under voltage input.
- **Orange** = The channel has been automatically turned “Off” due to an over or under voltage input but the input voltage is now within limits and the channel is about to automatically turn back on if the voltage stays with limits for 10 seconds.

The “Input Voltage High Limit” and “Input Voltage Low Limit” per phase can be set. If these limits

are exceeded, the outputs connected to that phase will be switched off and their input voltage displays will turn to red. See section 5.11.

The input current per phase is displayed in green. The readout turns orange as a warning when the input current reaches 90% of the maximum allowable current per phase.

Note: This reading is the total input current per phase. The maximum current per output channel is determined by the capacity of its front panel RCBO circuit breaker and is preset in the factory.

The Control Source status (bottom left corner of the home screen) shows the name of the selected “Control Source” and is green when the selected control source is present and flashes red when it is not present. See section 5.11.7 to select a control source.

The GPI status is green when a GPI signal (contact closure) is present on pins 1 and 4 of the “DMX Input” connector. See section 5.5.4.2

If the outputs are manually turned on or off from the touch screen (Manual APSX On/Off), then the DMX and GPI status indicators are replaced by a “Manual Mode” indicator. See section 5.8

Note: The APSX uses internal relays to switch the power on and off for each output. The RCBO’s (circuit breakers) on the front panel provide protection against current overload and excessive earth leakage. They are not designed to be used as an everyday switch due to the limited life expectancy of 1,000/2,000 cycles for an RCBO/MCB compared to >100,000 cycles for a relay or switch.

5.2 Help Screens

Some menus have “Help” screens available as indicated by a ? button in the top right corner of the touch screen. Press ? (when available) to see the help screen.

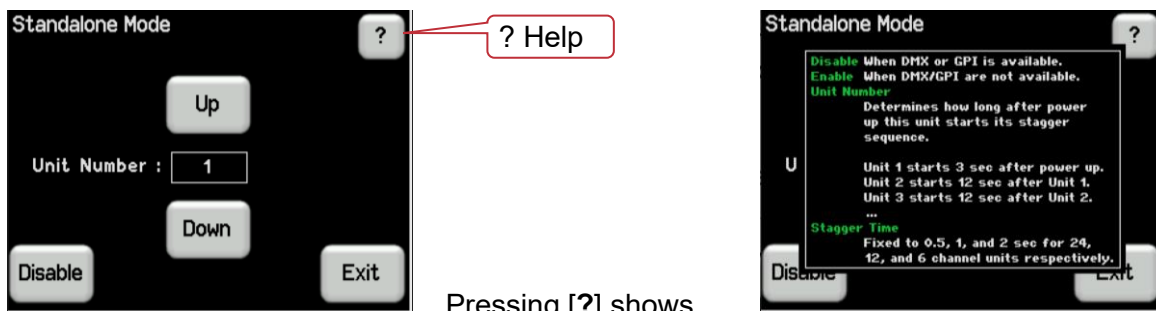

Press anywhere within the help screen to cancel.

5.3 Operating Modes

Every output channel can be individually configured to operate in any of the following modes:

- **DMX.** The channel is switched by the level of the DMX slot (address) of the selected control source to which it is patched. The control source can be either DMX, sACN or ArtNet. See section 5.5.1
- **OFF.** Always Off. See section 5.5.2
- **ON.** Always On. See section 5.5.3
- **APS.** The channels are sequentially switched on when triggered. There are several methods of triggering the “switch on” sequence. See section 5.5.4.
- **OSC.** The channel is switched by an OSC command via the Ethernet input. See section 5.5.5.

Note: In the unlikely event that the APSX does not respond to your commands, you can manually force the APSX to switch on all of its outputs. See section 5.10

5.4 Configuration Menu

Press anywhere on the **Home Screen** to access the “Configuration Menu”.

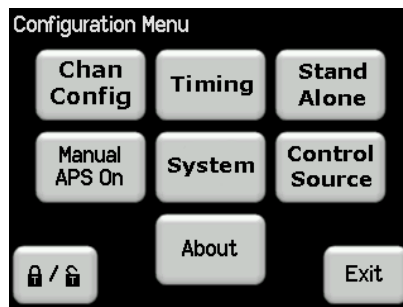

The configuration menu provides the following sub menus,

- Chan Config. See 5.5
- Timing. See 5.6
- Stand Alone. See 5.7
- Manual APS On/Off. See 5.8
- System. See 5.11
- Control Source. See 5.11.7
- About. See 5.12
- Lock/Unlock. See 5.13

5.5 Chan Config

To change the configuration of a channel, press anywhere on the **home screen** to reveal the “Configuration Menu” then press **Chan Config**.

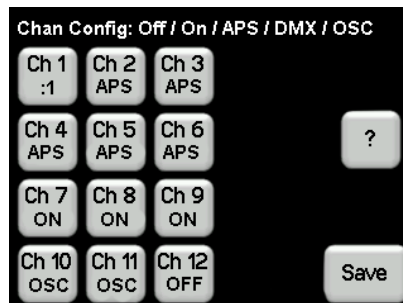

Each channel button shows its current configuration setting. Channels set to DMX also show the DMX slot number to which they are patched.

Select the channels to configure by pressing their numbers. Selected channels turn dark grey. When any channel has been selected the “Config” button appears. For example, if channels 1 and 2 were selected...

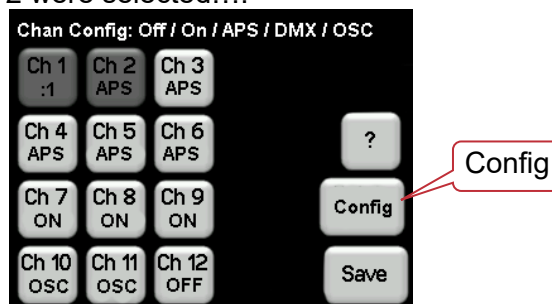

Press **Config**,

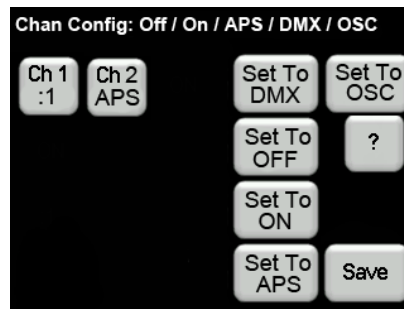

Press the desired configuration for the selected channel(s). The choices are,

- Set to DMX
- Set to OFF
- Set to ON
- Set to APS
- Set to OSC

Make your selection then press **Save**. Each of these configurations are described in detail below.

5.5.1 Set To DMX

Channels set to “DMX” are switched by the level of the DMX slot (address) of selected control source to which they are patched. The control source can be either DMX, sACN or ArtNet. To select a control source, see section 5.11.7.

This is the equivalent of a DMX controlled switch.

- A channel set DMX will switch ON when its DMX signal exceeds 60%
- A channel set DMX will switch OFF when its DMX signal drops below 40%.
- All Channels set to “DMX” are switched off when the selected control source is no longer present (after the adjustable “Power Off Delay” time). See section 5.6.2.

Note: The “DMX Thru” connector only becomes active after the APSX has completed the staggered switch on sequence of its APSX channels. This means that the next APSX unit, fed from to the DMX Thru connector, will only receive DMX after the current APSX has finished its switch on sequence.

To set an APSX channel to be DMX controlled, press anywhere on the **home screen** then press **Channel Config**. Select the channel(s) by pressing their numbers. Selected channels turn dark grey. Press **Set To DMX**.

The screen shows the channels set for DMX control and their DMX slot number if they have already been patched or “---” if they have not been patched.

- To patch a channel (or change the DMX slot of an existing patch) press the channels to be patched (or changed) and then press **Patch DMX**
- If the DMX address is correct (as shown on each channel button) press **Save**.

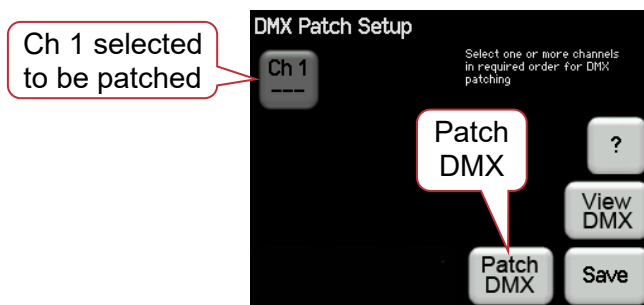

The “Set DMX Address” keyboard appears.

Enter the DMX channel number to control this channel. Multiple APSX channels can be selected and they will be patched in the order that they were selected to sequential DMX slots starting from the DMX slot number that you enter. A single DMX slot number can be patched to control multiple channels.

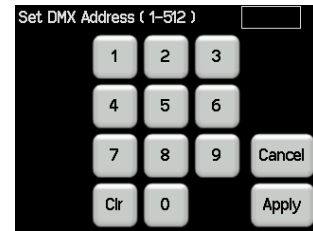

Press **Apply**.

5.5.1.1 View DMX

On the “DMX Patch Setup” screen (see above), pressing **View DMX** shows the channel levels of the DMX signal of the currently selected control source, DMA, sACN or ArtNet.

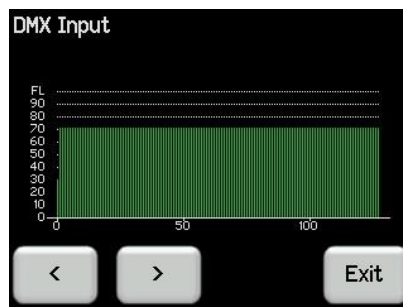

Press either > or < to scroll through the DMX channels.

5.5.2 Set to Off

Channels set to “OFF” are always off and cannot be turned on by the APSX. The channel icon of OFF channels at the top of the home screen has a X.

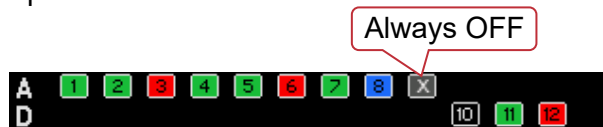

To set an APSX channel to be always off, press anywhere on the **home screen** then press **Channel Config**. Select the channel(s) by pressing their numbers. Selected channels turn dark grey. Press **Set To OFF**, then **Save**.

5.5.3 Set To On

Channels set to “ON” are always on whenever power is applied to the APSX. All control of the channel is ignored except that any ON channels will still turn off if the supply volts are outside the set limits. The channel icon of ON channels at the top of the home screen is blue.



To set an APSX channel to be always on, press anywhere on the **home screen** then press **Channel Config**. Select the channel(s) by pressing their numbers. Selected channels turn dark grey. Press **Set To ON**, then **Save**.

5.5.4 Set To APS

Channels set to “APS” are switched on sequentially to minimise surge current. This is also known as a “staggered switch on”. The time delay between channels switching on can be set using the touch screen. See section 5.6.1.

To set a channel to APS control, press anywhere on the **home screen** then press **Channel Config**. Select the channel(s) by pressing their numbers. Selected channels turn dark grey. Press **Set To APS** then **Save**.

All APS controlled channels can be sequentially switched on via any of the following methods as described below,

- Control signal presence. See 5.5.4.1
- GPI (General Purpose Input) contact closure. See 5.5.4.2
- Stand Alone Mode (presence of input power). See 5.7
- Manual Mode (using the touch screen). See 5.8

5.5.4.1 Control Signal Presence.

The APS switch on sequence is started whenever the selected control signal is detected. In this mode, the APSX does not use a DMX slot (address) and is not controlled by DMX levels. It only responds to the presence or absence of a valid selected control signal. To select a control signal see section 5.11.7

When multiple APSX units are cascaded from “DMX THRU” to “DMX INPUT”, the DMX signal is not passed on to the “DMX THRU” connector until the APSX has completed its switch on sequence thus delaying the DMX signal to the next APSX. The next APSX will then detect the DMX signal, switch on its channels and repeat the procedure.

When the selected control signal is no longer present (when the lighting controller is switched off) the APSX will switch off all channels after the adjustable “Power Off Delay” time. See section 5.6.2

5.5.4.2 GPI.

The GPI function allows a single APSX or multiple APSX units to be remotely controlled by a single switch. Pins 1 and 4 of the “DMX INPUT” connector are used as a GPI (General Purpose Input). When a contact closure is detected between pins 1 and 4 of the “DMX INPUT” connector, the switch on sequence of the “APS” channels is started.

When multiple APSX units are cascaded, pins 1 and 4 of the “DMX THRU” connector are used as a GPO (General Purpose Output) and connected to pins 1 and 4 of the “DMX INPUT” of the next APSX. The APSX “DMX THRU” connector will automatically provide a contact closure between pins 1 and 4 at the completion on its switch on sequence thus sending the contact closure to the next APSX. The next APSX will then detect the GPI signal and repeat the procedure.

When the contact closure between pins 1 and 4 of the “DMX INPUT” is opened the APSX will switch off all channels after the adjustable “Power Off Delay” time and also open pins 1 and 4 of its DMX THRU connector thus switching off the next APSX.

5.5.4.3 GPI Cables

To make a GPI input cable, connect a switch (contact closure) between pins 1 and 4 of a 5-pin female XLR plug and plug it into the DMX INPUT connector of the APSX.

To make a GPI loop cable to connect the GPI THRU of one APSX to the GPI INPUT on the next APSX connect pins 1 and 4 of a 5-pin male XLR plug to pins 1 and 4 of a 5-pin female XLR plug respectively. You can also use commercially available DMX cables if they have pins 1 and 4 connected. DMX uses pins 1 (ground), 2 (- data) and 3 (+ data) however the DMX standard specifies pins 4 and 5 as an optional secondary data link so most DMX cables connect all 5 pins.

5.5.5 Set To OSC

OSC (Open Sound Control) is a protocol for real time control between third party devices.

APSX channels that have been set to “OSC” can be switched on or off by OSC command messages sent from an OSC device. If multiple channels are set to OSC and an OSC “On” command is received, the channels will sequentially switch on. See section 5.6.1

Whenever a received command has been executed by the APSX, a message is sent back to the controlling device via OSC, confirming that the APSX has responded.

5.5.5.1 OSC commands

APSX uses OSC via UDP and uses port 50142 for receiving and sending messages.

You can send a message to a single unit via its specific IP address, for example 192.168.4.45 or as a “broadcast” using 192.168.4.255. Sending to “broadcast” and using the * wildcard for the “unit name” allows you to control multiple units simultaneously. See below for more information on “unit name”.

Get Channel

The “GetChannel” command is used to interrogate the current status (on or off) of an APSX channel. It is recommended to send this command first for all channels so that the controlling device knows the current state of the APSX channels.

The format is;

/LSC/APSX/unitname/GetChannel/num

unitname - this is the name of the unit. By default the unit name is APSX-xxxx where xxxx is the last 4 digits of the RDM ID. You can find the RDM ID of an APSX by pressing anywhere on the **Home Screen**, then **About**. You can also use an * as the unit name. This works as a wildcard and all units sent the message will respond.

Num - The channel number/s to control. These can be an integer with a value between 1 and 12 inclusive, or a range of channels, shown as two integers separated by a dash, inside square brackets. For example, [1-12]

Channel Status Replies

In response to the GetChannel messages (above), the APSX replies with a Channel Status message/s. This applies to all channels irrespective of their “Channel Config” (DMX, Off, On APS or OSC). These message/s are broadcast to the entire subnet.

For example, if the APSX IP address and subnet are 192.168.42.17 and 255.255.255.0, the reply will be sent to 192.168.42.255.

They use the same port as the incoming messages - **51042**

The format is;

/LSC/APSX/unitname/ChanState/num, i level

Set Channel

The “SetChannel” command is used to set the status (on or off) of any APSX channel that is set to OSC in the “Channel Config” menu.

The format is;

/LSC/APSX/unitname/SetChannel/num, i level

or

/LSC/APSX/unitname/SetChannel/num, bool

unitname - this is the name of the unit, By default the unit name is APSX-xxxx where xxxx is the last 4 digits of the RDM ID. You can find the RDM ID of a APSX by pressing anywhere on the **Home Screen**, then **About**. You can also use an * as the unit name. This works as a wildcard and all units sent the message will respond.

Num - The channel number/s to control. These can be an integer with a value between 1 and 12 inclusive, or a range of channels, shown as two integers separated by a dash, inside square brackets. eg. [1-12]

Level- An integer between 0 and 100. The APSX only accepts two values, 0 (off) and 100 (on).

or

Bool- A Boolean with a value of T or F. The T is true and turns the channel on, False turns the channel off.

5.6 Timing

Pressing anywhere on the **Home Screen** then pressing **Timing** allows you to set the timing parameters.



5.6.1 Stagger Power On

When the command to switch on the outputs is executed, the outputs under APS or OSC control are sequentially switched on to avoid an excessive surge current on the power supply. “Stagger Power On” is the delay time between switching on each output. The range is from 0.1 to 5 seconds. The default time is 1 second. To change the stagger power on time, select the “Timing” screen as described above then in the “Stagger Power On” pane press **Edit**. Type in the required time then press **Apply**.

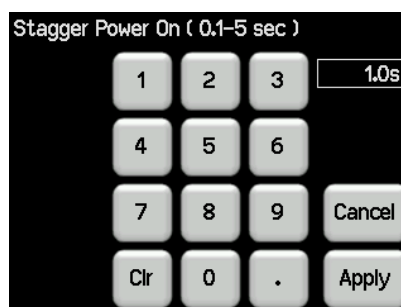

Note: In Standalone mode, stagger time is fixed. See section 5.7

5.6.2 Power Off Delay

Power off delay is the time that the outputs stay on when either the selected control signal is lost or the GPI input contact closure is opened. The range is 0 (instant off) to 60 minutes or infinite. The default time is 5 minutes. To change the power off delay, select the “Timing” screen as described above then in the “Power Off Delay” pane press **Edit**. Type in the required time then press **Apply**.

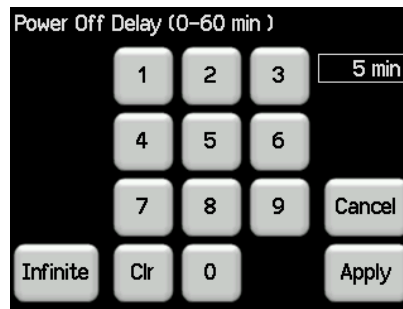

5.6.3 Warning Beep

If the selected control signal is lost or the GPI input contact closure is opened, the countdown to power off begins. When it reaches 1 minute a “warning beep” sounds (if enabled). When it reaches 30 seconds a warning appears on the screen and counts down the remaining time to switch off. The warning beep can be enabled or disabled from the “Timing Parameters” menu described above.

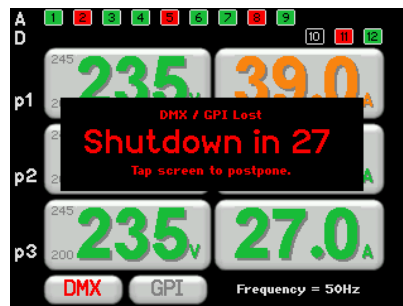

You can postpone the switch off and restart the countdown timer by tapping the screen. To disable the automatic switch off, set the “Power off delay” time to “Infinite”.

*Hint: If the APSX about to turn off and you want to keep it on, press the screen to postpone the shutdown then press anywhere on the **Home screen** then press **Stand Alone, Enable**.*

5.7 Stand Alone

In standalone mode, the APSX will automatically start its staggered switch on sequence of channels that are set to “APS” mode, 3 seconds after power is applied at the input.

To select “stand alone” mode, press anywhere on the **Home Screen** then press **Stand Alone, Enable**.

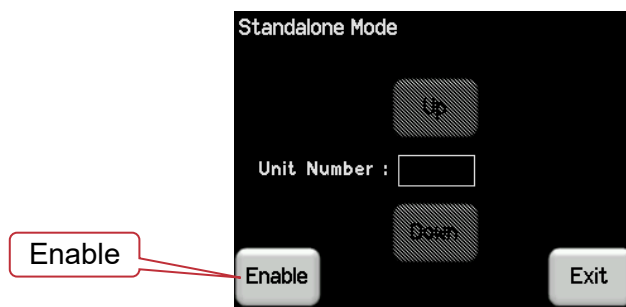

If multiple APSX units are to be operated in Stand Alone Mode, you can prevent them from all starting their staggered switch on sequence at the same time by assigning a different “unit number” to each APSX.

Each unit number adds an additional 12 second delay to the start of the staggered switch on sequence.

- Unit 1 starts after 3 seconds.

- Unit 2 starts after 15 seconds.
- Unit 3 starts after 27 seconds etc.

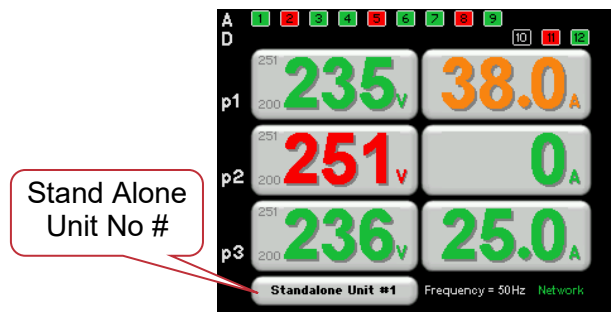

In standalone mode, the “Stagger Power On” times of the output channels are fixed to ensure that channels in different size APSX units do not turn on at the same time.

- 6 channel APSX units have a fixed stagger time of 2 seconds.
- 12 channel APSX units have a fixed stagger time of 1 second.

5.8 Manual Mode.

If the APS controlled outputs are OFF pressing anywhere on the **Home Screen**, then **Manual APS On**, starts the switch-on sequence of “APS” channels.

If the APS controlled outputs are ON, pressing anywhere on the **Home Screen** then **Manual APS Off** switches off all “APS” channels after you say “yes” to a confirmation warning.

To exit manual mode, connect the selected control source signal to the APS or trigger the GPI input.

5.9 RDM Control

Channels can also be remotely turned on or off by RDM. See section 6.5

5.10 Emergency Mode

In the unlikely event that the APSX does not respond to your commands, you can manually force the APSX to switch on all outputs. There is a small hole located on the front panel below the touch screen. Inside there is a button which, when pressed with a small pin or paperclip, turns ON all outputs (simultaneously) and shuts down the APSX monitoring and control system. The touch screen backlight remains on to show the presence of input power.



WARNING.

“Emergency Mode”
switch access hole

Only use this method of turning on the APSX channels as a last resort. The following action will turn the channels on, even if the system has shut down the output due to a dropped neutral or over voltage input. Be aware that taking this action may result in damage to any connected equipment. The APSX remains in this mode until input power is removed.

5.11 System

Touch anywhere on the **Home Screen** then press **System**. The “System” menu provides the following sub-menus,

- Limits
- Reset
- Service
- Fan Control
- Colour Theme
- Network

5.11.1 Voltage Limits

Press anywhere on the **Home Screen** then press **System, Limits**.

The “Limits” menu allows you to set maximum (High) and minimum (Low) limits on the input voltage for each phase to protect the equipment connected to that phase. If these limits are exceeded, the input voltage display for that phase turns red and the outputs connected to that phase will be switched off and their status indicators also turn red.

When the input voltage returns to within the limits, the input voltage display turns green and the channel status indicators turn orange, but the outputs will remain off until the following conditions are met for each limit,

- High. The input voltage drops to 3 volts below the high limit for at least 10 seconds
- Low. The input voltage rises to 3 volts above the low limit for at least 10 seconds

The channels then automatically turn back on after their staggered start up time delay. Pressing **Limits** (in the Configuration menu) shows the limit settings for each phase.

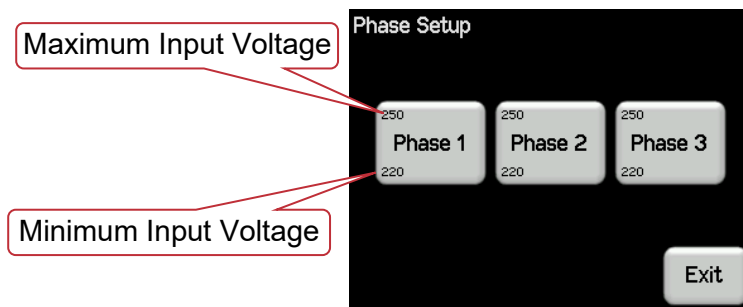

Pressing a **Phase** button allows you to select either the Low or High limit for that phase. These limits are also shown on the “Home” screen.

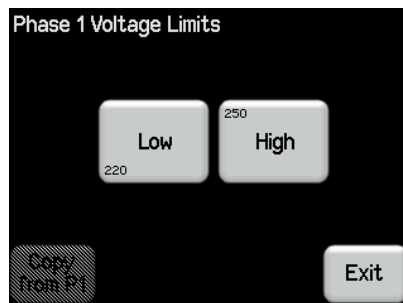

Pressing either **Low** or **High** allows you to set that limit.

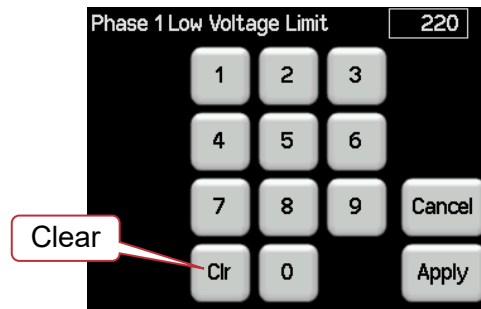

When phases 2 or 3 are selected, the settings for phase 1 can be copied to them by pressing **Copy from P1**.

The limits of each phase are also shown on the “Home” screen.

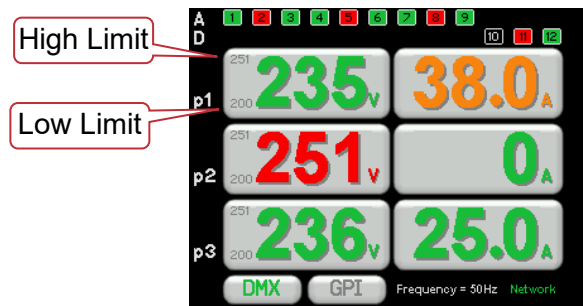

5.11.1.1 Removing Limits

To remove a limit on a phase press either **Low** or **High** then press **Clr** (Clear) then **Apply**.

5.11.1.2 Default Limits

If no limits have been set then a high limit of 270 volts still exists.

If any phase reaches 270 volts then all outputs are turned off.

Normal operation is restored when the input voltage drops below 260 volts.

5.11.2 Reset

Press anywhere on the **Home Screen** then press **System, Reset**. There are two options:

5.11.2.1 Restart

In the unlikely event that the APSX fails to respond, the operating system may be restarted so that the software may initialise and recommence normal operation. Pressing **Restart** will not affect any of the settings or memory.

5.11.2.2 Reset To Defaults

This menu is locked by the service lock. See section 5.13

This will ERASE all memory from the APSX (except the owner name) and reset to defaults.

The default settings are:

- Set all channels to APSX control
- Stagger power on = 1second
- Power off delay = 5 minutes
- Remove all phase voltage limits
- Disable “Stand Alone” mode
- Set to Manual Mode

5.11.3 Service

Press anywhere on the **Home Screen** then press **System, Service**. The Service menu is locked by default. It is primarily for factory use. It can be unlocked from the “Service Lock” menu. See section 5.13.

5.11.4 Fan Control

Press anywhere on the **Home Screen** then press **System, Fan Control**. The Fan Control menu is locked by default. It can be unlocked from the “Service Lock” menu. See section 5.13. Press **Set Speed**. The default fan speed is 30 but you can enter a number up to 100 then **Apply**.

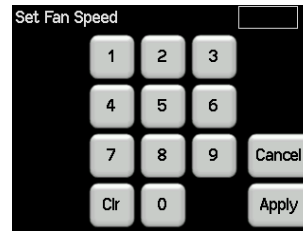
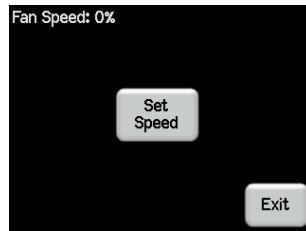

5.11.5 Colour Theme

Press anywhere on the **Home Screen** then press **System, Colour Theme**. You can choose a colour theme for the touch screen. The choices are:

- Gothic (Default)
- Antarctic
- Dawn

5.11.6 Network

Press anywhere on the **Home Screen** then press **System, Network**.

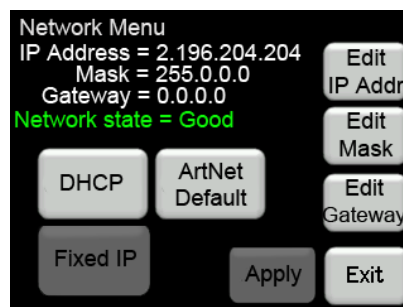

Fixed IP Menu

This menu is used to select the IP address that is used for this APSX. The network address can be set manually (known as a Fixed IP) or it can be automatically assigned by your network using a DHCP server. The setting of IP addresses is dependent on the network being used and the choice of static or DHCP and other network parameters is beyond the scope of this document.

- To have a network address automatically assigned, press **DHCP**.
- To manually enter a network press **Fixed IP** then use the **Edit IP Address**, **Edit Mask** and **Edit Gateway** buttons. A pop-up keyboard allows entry of the required settings.
- To automatically enter the network settings for Art-Net, press **ARTNET DEFAULT**. This will give the system an address in the ArtNet range. The address will be 2.x.y.z where the x.y.z is calculated from the unique MAC address of the network interface card. This allows many ArtNet devices to start up on the same network where there is no DHCP and each device will have a unique IP.

Press **Apply** to keep your settings and exit.

Hint: If the APSX is set to DCHP, it will look for a DHCP server when it starts. It waits 10 seconds for a response. If there is no response, it times-out and sets an automatic IP address (169.x.y.z). This is as per the DHCP standard. Windows and Mac computers do the same thing. Modern ethernet switches can take 90-120 seconds to boot up. If you apply power to APSX and the ethernet switch at the same time, GENX may boot up before the ethernet switch is transmitting

the DHCP data. However, LSC products resend the DHCP request every 10 seconds. If a DHCP server comes online later, APSX will then automatically change to a DHCP assigned IP address. This feature applies to all LSC products with internal ethernet.

Note. To use sACN or Art-Net protocols, APSX must have a valid IP address and NetMask set to work correctly. When using Art-Net, it is essential that the IP address is set to be compatible with the address on the device sending the Art-Net packets.

Streaming ACN utilizes multicasting and as such the actual IP address in use is generally irrelevant.

Note: The APSX might take up to 15 seconds to establish a network connection.

5.11.7 Control Source.

Channels that are set to “APS” will be sequentially switched on when the presence or the selected “Control Source” signal is detected. A loss of the selected control signal turns APS channels off after a pre-set time delay.

Press anywhere on the **Home Screen** then press **System, Control Source**. The choices are: ArtNet, sACN, DMX. If ArtNet or sACN are selected, use the **Set Universe** button to choose the required universe.

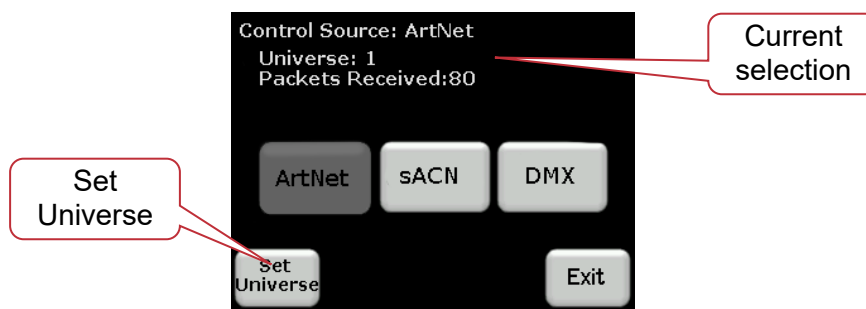

The selected source has a dark button.

5.12 About

To see the “About” menu, press anywhere on the **Home Screen** then **About**.

The “About” menu shows information about the software, capacity and owner of the APSX.



5.12.1 Owner

Warning: If you enter an owner name and or logo and press “Lock”, this is permanently locked and can only be changed by an authorised LSC dealer. You must set the name and logo before pushing Lock. Once Lock has been pressed, the name and logo cannot be changed without contacting the factory. This acts as a deterrent against theft of your APSX.

From the “About” menu, above, pressing **Owner** allows you to enter a permanent name for the APSX (“This unit belongs to:”) and also allows you to set a “Logo” that will be momentarily displayed when power is applied to the APSX (instead of the LSC logo).

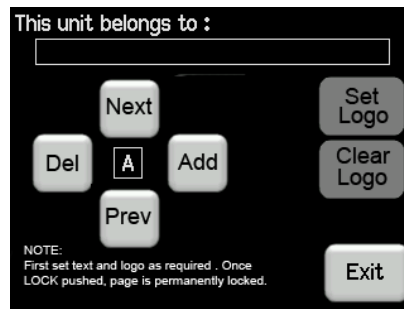

To enter an owner name, use the **Next** and **Prev** buttons to select a character then **Add** to enter the character or **Del** to delete a character.

To set a custom logo a special file must be present on an SD card inserted in the APSX. There is a fee for LSC to convert your logo into the special file that will load into your APSX. Please contact LSC or your LSC agent for details.

When the owner name and/or logo have been entered, the Exit button changes to “Lock”. To permanently lock in your changes, press **Lock**.

5.13 Lock / Unlock

To lock the touch screen and prevent unauthorised access, press anywhere on the **Home Screen**, then press the **Padlock** symbol.

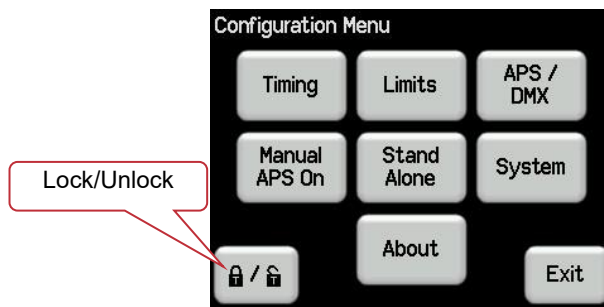

Pressing the **Padlock** symbol provides 2 levels of lock.

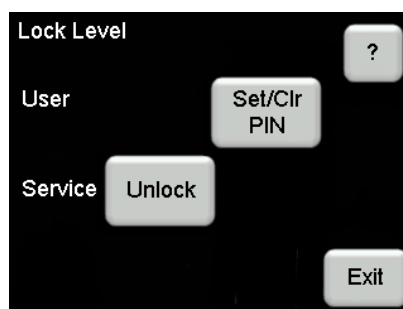

- User. Prevents all configuration changes. To set a PIN, press **Set/Clr PIN**. Enter a four-digit code. Entering 0000 clears the PIN.
- Service. This lock level is primarily for factory use however it also unlocks the “Reset to Defaults” and the “Fan Control” functions. The unlock PIN code is 3333.

If a PIN has been set, its “Lock” or “Unlock” button appears. Press **Lock** (or **Unlock**) to perform that task. You will be required to enter your PIN to unlock.

If a level has been locked, its “Set/Clr PIN” button is hidden.[mb1]

5.14 Software Update

LSC Control Systems Pty Ltd has a corporate policy of continuous improvement, covering areas such as product design and documentation. To achieve this goal, we undertake to release software updates for all products on a regular basis.

APSX software updates are performed over Ethernet from LSC's HOUSTON X software which is available as a free download from the LSC website, www.lsccontrol.com.au.

Download the latest software for the APSX from the same site and save it to a known location on your computer. The file name will be in the format, ApsX_xx.xxx.upd where xx.xxx is the version number.

The computer running HOUSTON X and the APSX should be connected a managed network switch.

Hint: When choosing a network switch, LSC recommends the use of "NETGEAR AV Line" switches. They provide a preconfigured "Lighting" profile that you can apply to the switch so that it easily connects with sACN(sACN) and Art-Net devices.

Hint: If there is only one APSX in use, it can be connected directly to the HX computer without a switch.

To run the program double click "HoustonX.exe".

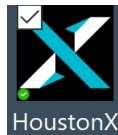

The APSX is set in the factory to DHCP (Dynamic Host Configuration Protocol). This means that it will be automatically issued with an IP address by the DHCP server on the network. Most managed switched include a DHCP server. You can set APSX to a static IP. See section 5.11.6

Hint: If APSX is set to DHCP, it will look for a DHCP server when it starts. If you apply power to APSX and the ethernet switch at the same time, APSX may boot up before the ethernet switch is transmitting the DHCP data.

Modern ethernet switches can take 90-120 seconds to boot up. APSX waits 10 seconds for a response. If there is no response, it times-out and sets an automatic IP address (169.x.y.z). This is as per the DHCP standard. Windows and Mac computers do the same thing.

However, LSC products resend the DHCP request every 10 seconds. If a DHCP server comes online later, APSX will then automatically change to a DHCP assigned IP address. This feature applies to all LSC products with internal ethernet.

If HOUSTON X detects more than one Network Interface Card (NIC) on the computer it will open the "Select Network Interface Card" window. Click the NIC that is being used to connect to your APSX.

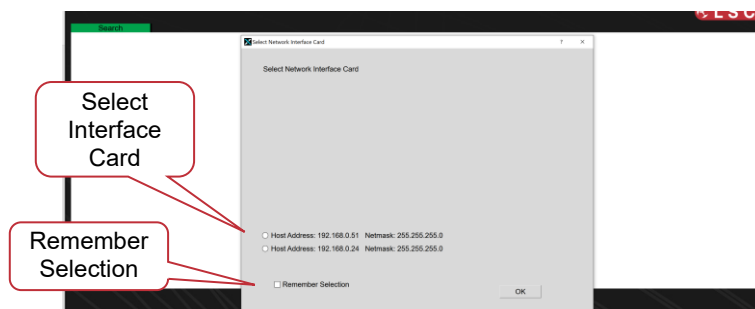

If you click “Remember Selection”, HOUSTON X will not ask you to select a card the next time you start the program.

HOUSTON X will automatically discover all compatible LSC devices that are on the same network. An APS tab will appear at the top of the screen. Click on the APS tab (its tab turns green) to see a summary all APSX’s on the network.

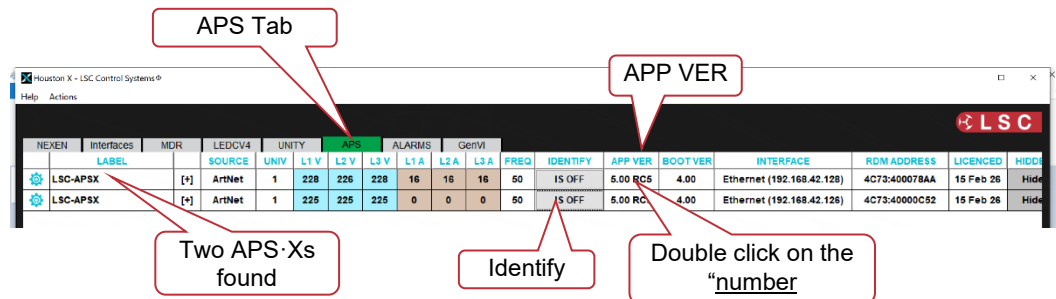

You can use the IDENTIFY function on HOUSTON X to ensure that you are selecting the correct APSX. Clicking an IDENTIFY **IS OFF** button (it changes to **IS ON**) and the touch screen of that APSX will show “Identify”.

The “APP VER” cell shows you the current version number of the APSX software. To update the APSX software, double click on the version number of the APSX that you wish to update.

A “Find Update File” window opens. Navigate to the location where you saved the downloaded software and click on the file then click **Open**.

Follow the on-screen instructions and the APSX software will be updated.

6 Control Protocols

6.1 DMX

DMX512/1990-A is the industry standard for the transmission of digital control signals between lighting equipment. It utilises just a single pair of wires on which is transmitted the level information for the control of up to 512 DMX slots (addresses or channels). The information for each slot is sent sequentially. The level of slot 1 is transmitted, then the level of slot 2, then 3, etc. up to a maximum of 512 slots. This stream of data containing the levels for all 512 DMX slots is repeated a minimum (Generally) of 44 times per second. This provides sufficient updates of channel information for smooth fade transitions.

As the DMX512-A signal contains the level information for all slots, each piece of equipment needs to be able to read the level(s) of the slots(s) that apply only to that piece of equipment. To enable this, the APSX has a “DMX Patch” menu that allows you to patch (connect) each DMX slot (address) from your lighting controller to a APSX channel number or to multiple channel numbers.

When good quality data cables are used, DMX512 cable runs may be up to 1,000 metres in length. When several DMX feeds are required (to feed different locations), DMX512 splitters must be used. These provides multiple isolated DMX512 feeds. The GENX uses a high impedance DMX input circuit allowing you to loop the DMX signal from one GENX to the next. The last GENX in the chain must have the “DMX Terminate switch” set to TERM to terminate the line.

Note: Do not use unscreened microphone or low speed data cables for DMX. This can cause problems in the DMX network. Make sure the cable conforms to the EIA485 cable requirements by providing the following specifications:

- Low capacitance
- One or more twisted pairs
- Foil and braid shielded
- Impedance of 85 -150 Ohms, nominally 120 Ohms
- 22AWG gauge for continuous lengths over 300 metres

6.2 ArtNet

ArtNet (designed by and copyright, Artistic Licence Holdings Ltd) is a streaming protocol to transport multiple DMX universes over a single Ethernet cable/network. APSX supports Art-Net v4. There are 128 Nets (0-127) each with 256 Universes divided into 16 Subnets (0-15), each containing 16 Universes (0-15).

6.3 sACN

Streaming ACN (sACN) is an informal name for the E1.31 streaming protocol to transport multiple DMX universes over a single cat 5 Ethernet cable/network.

6.4 RDM

RDM stands for Remote Device Management. It is an “extension” to DMX. Since the inception of DMX, it has always been a ‘one way’ control system. Data only ever flows in one direction, from the lighting controller outwards to whatever it may be connected to. The controller has no idea what it is connected to, or even if what it's connected to is working, switched on, or even there at all!

RDM changes all that allowing the equipment to answer back!

An RDM enabled moving light, for example, can tell you many useful things about its operation - the DMX address it is set to, the operating mode it is in, whether its pan or tilt is inverted and how many hours since the lamp was last changed.

But RDM can do more than that. It isn't limited to just reporting back, it can change things as well. As its name suggests, it can remotely manage your device.

RDM has been designed to work with existing DMX systems. It does this by interleaving its messages with the regular DMX signal over the same wires. There is no need to change any of your cables but because RDM messages now go in two directions, any in-line DMX processing you have needs to be changed for new RDM hardware. This will most commonly mean that DMX splitters and buffers will need to be upgraded to RDM capable devices.

To utilise RDM you will also need an RDM controller. These are devices that plug in to the DMX line and talk the RDM language. They put the messages on to the DMX line, listen for any replies and display the results via an attached computer. The latest lighting consoles now also come with RDM controllers built in.

RDM also has the ability to read and report operating statistics and error conditions from any enabled equipment that supports it.

To use RDM, DMX must be selected as the “Control Source” (see section 5.11.7).

6.4.1 ArtRdm

ArtRdm is a protocol that allows RDM (Remote Device Management) to be transmitted via ArtNet.

To use ArtRdm, ArtNet must be selected as the “Control Source” (see section 5.11.7).

6.5 APSX RDM Commands

APSX provides the following functions over RDM:

- Over/Under voltage, over current and shutdown events are reported as “alarms.”

Global Commands:	
Identify (Quiet)	Blinks a message on the screen.
ReStart/Reboot	
Get Device Name	
Get/Set Device Label	
Get Software version	
Get BootLoader version	
Get RDM ID	
Get DMX state (Sensor)	Presence of DMX
Get GPI state (Sensor)	
Get Fan Speed (Sensor)	
Get P1/P2/P3 state (Sensor)	Presence of input power phases
Get P1/P2/P3 voltage (Sensor)	
Get P1/P2/P3 current (Sensor)	
Get mains frequency (Sensor)	
Get channel state (Sensor)	
Get/Set Power State	Used to turn APS channels on/off. It replicates the [Manual APS On/Off] button.
Sub-Devices (3, 6 or 12) Commands	
Get/Set Device Label	

7 HOUSTON X

HOUSTON X is LSC's monitoring and remote configuration tool that works with LSC products such as APSX, GEN VI, MDR-DIN, LED-CV4, UNITOUR, UNITY and Mantra Mini. HOUSTON X can be downloaded from the LSC website, www.lsccontrol.com.au



HOUSTON X is the central overseer of your venue's equipment. The software runs on Windows and Mac computers. It gives you the absolute authority to interrogate, monitor and instantly change parameters of connected products.

Using HOUSTON X, you can quickly locate and isolate faults, monitor temperatures, phase loadings, change a channel from dimmer to power-switching mode (TruPower), save or recall show configurations, all from one central location or remotely via the internet.

Some LSC products have additional functionality enabled when licensed to operate with HOUSTON X.

8 Maintenance and Troubleshooting

Warning. No user controls or user serviceable parts are located inside the APSX. Refer all servicing to suitably qualified personnel.

8.1 Maintenance



Ensure that the air vents at the side of the frame are free from obstruction and dust.
Check that all connector screw terminals (if fitted) are tight. This must be performed by a suitably qualified person.
Check that the APSX contains the latest software release.







8.2 Tripped Breakers

If a channel is not working check the MCB (Miniature Circuit Breaker) for that channel.
If the MCB has tripped (OFF), firstly try to determine the cause of the breaker tripping. It could be a blown lamp or a circuit overload or and earth leakage fault. Remember that the touch screen shows the load current per phase, not per channel. Rectify to problem (replace the lamp or reduce the load) then restore the MCB. If the MCB continues to trip, refer the problem to a suitably qualified person.

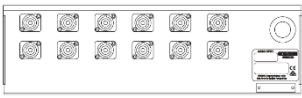
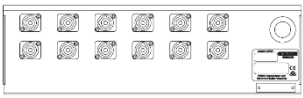
9 Specifications and Output Options

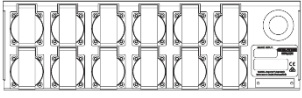
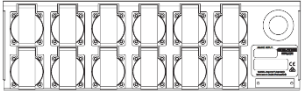
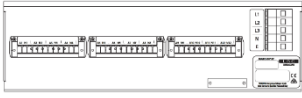
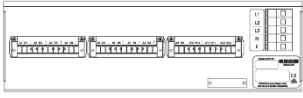
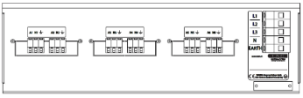
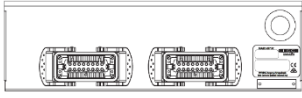
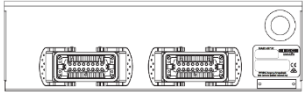
9.1 Rackmount APSX

Rackmount Models	12 x 10A	12 x 16A Export Only	6 x 25A
Control	3.2" colour LCD with touch screen Programmable stand-alone mode via easy-to-use menus DMX512 (1990) or DMX512-A (E1-11) input with RDM (E1-20) functionality on 5-pin XLR connectors GPI voltage free contact closure on 5-pin XLR connectors (using pins 1+4)		
Protection	10A Residual Current Breaker (RCBO) per output channel	16A Residual Current Breaker (RCBO) per output channel	25A Residual Current Breaker (RCBO) per output channel
	30mA Earth leakage trip current per channel Dropped neutral protection with almost instant load disconnect Programmable channel sequential start-up time delay Cascading start-up between multiple units Programmable min and max voltage cut-off per phase		
Monitoring	3-phase voltage and current levels monitoring on main display Remote configuration and monitoring via RDM protocol Remote configuration and monitoring via LSC's HOUSTON X software		
Power	Nominal 100-240V, 3-phase star, 50-60Hz (single-phase operation possible, 63A maximum) Operating range typically 90-260V, 45-65Hz Hardwired models supplied with L1, L2, L3, N and E terminals for power connection. All other models as per below		
	Supplied with 1.2m long H07 rubber 5 core x 6mm ² cable. (Export models supplied without connector, Australian models supplied with 32A 5-pin 3-phase plug fitted)	Supplied with 1.2m long H07 rubber 5 core x 10mm ² cable no connector supplied. (Export only. Not available in Australia)	Supplied with 1.2m long H07 rubber 5 core x 6mm ² cable. (Export models supplied without connector, Australian models supplied with 40A 5-pin 3-phase plug fitted)
Mechanicals	483mm (w) x 300mm (d) x 132mm (h) Weight: 11kg Full metal chassis with rear-screened polycarbonate labels Touch screen, DMX input, GPI input and RCBOs located on front panel Output connectors and power input cable located on rear panel		
Peace of mind	CE (European) and RCM (Australian) approved Two-year warranty Designed and manufactured in Australia by LSC, an Australian owned company with over 40 years' experience in developing world-first product		
Outputs	APSX12/10A  12 x 3-pin 10 Amp Australian sockets		APSX6/25A  6 paired 3-pin 20Amp/15Amp Australian sockets

Rackmount Models	12 x 10A	12 x 16A Export Only	6 x 25A
	<p>APSX12/10P</p>  <p>powerCon</p>	<p>APSX12/16P</p>  <p>powerCon</p>	
	<p>APSX12/10PT1</p>  <p>powerCon True1Top</p>	<p>APSX12/16PT1</p>  <p>powerCon True1Top</p>	
	<p>APSX12/10S</p>  <p>CEE7</p>	<p>APSX12/16S</p>  <p>CEE7 (Schuko)</p>	
	<p>APSX12/10T</p>  <p>Hardwired terminals</p>	<p>APSX16/10T</p>  <p>Hardwired terminals</p>	<p>PWP6/25T</p>  <p>Hardwired terminals</p>
	<p>APSX12/10W</p>  <p>2 x 16-pin Wieland</p>	<p>APSX12/16W</p>  <p>2 x 16-pin Wieland</p>	
	<p>APSX12/10X</p>  <p>2 x 19-pin Socapex</p>	<p>APSX12/16X</p>  <p>2 x 19-pin Socapex</p>	
	<p>APSX12/10XPT1</p>  <p>2 x 19-pin Socapex plus 3 powerCon True1Top in parallel with channels 1-3 of the Socapex</p>	<p>APSX12/16XPT1</p>  <p>2 x 19-pin Socapex plus 3 powerCon True1Top in parallel with channels 1-3 of the Socapex</p>	

9.2 Wallmount APSX

Wallmount Models	12 x 10A	6 x 25A
Control	<p>3.2" colour LCD with touch screen Programmable stand-alone mode via easy-to-use menus DMX512 (1990) or DMX512-A (E1-11) input with RDM (E1-20) functionality on 5-pin XLR connectors GPI voltage free contact closure on 5-pin XLR connectors (using pins 1+4)</p>	
Protection	<p>12 channel x 10A RCBO breakers with 30mA trip per channel</p>	<p>6 channel x 25A RCBO breakers with 30mA trip per channel</p>

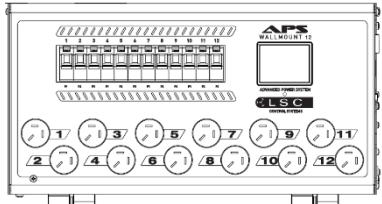
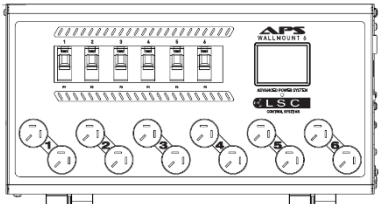
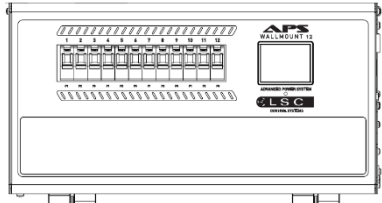
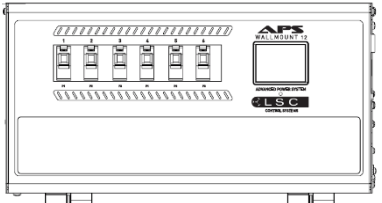
	<p>Dropped neutral protection with almost instant load disconnect</p> <p>Programmable channel sequential start-up time delay</p> <p>Cascading start-up between multiple units</p> <p>Programmable min and max voltage cut-off per phase</p>	
Wallmount Models	12 x 10A	6 x 25A
Monitoring	<p>3-phase voltage and current levels monitoring on main display</p> <p>Remote configuration and monitoring via RDM protocol</p> <p>Remote configuration and monitoring via LSC's HOUSTON X software</p>	
Power	<p>Nominal 100-240V, 3-phase star, 50-60Hz (single-phase operation possible, 63A maximum)</p> <p>Operating range typically 90-260V, 45-65Hz</p> <p>All models supplied with L1, L2, L3, N, and E terminals for power connection</p>	
Mechanicals	<p>490mm (w) x 270mm (d) x 250mm (h)</p> <p>Weight: 16kg</p> <p>Full metal two-part hinged chassis with rear-screened polycarbonate labels</p> <p>Touch screen, dimmer output connectors, RCBOs located on front panel</p> <p>DMX input and GPI input located on right side panel</p> <p>Input power terminals housed internally, optional cable gland to allow flying tail to be connected</p>	
Peace of Mind	<p>CE (European) and RCM (Australian) approved</p> <p>Two-year warranty</p> <p>Designed and manufactured in Australia by LSC, an Australian-owned company with over 40 years' experience in developing world-first products</p>	
Outputs	<p>APW12/10A</p>  <p>12 x 3-pin 10 Amp Australian sockets</p>	<p>APW6/25A</p>  <p>6 paired 3-pin 20Amp/15Amp Australian sockets</p>
	<p>APW12/10T</p>  <p>Hardwired internal terminals</p>	<p>APW6/25T</p>  <p>Hardwired internal terminals</p>

9.3 Wieland Pinouts

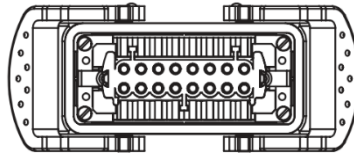

WARNING. Several wiring standards exist for the pin outs of Wieland multipin sockets. If in doubt, a suitably qualified person should check that your Wieland cables are wired to the same standard as your APSX.

Note: Earth connection is via the clips on the side of the socket insert.

9.4 Socapex Pinouts

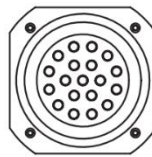

Connector #1	Function	Connector #2	Function
Pin 1	Chan 1 Active	Pin 1	Chan 7 Active
Pin 2	Chan 1 Neutral	Pin 2	Chan 7 Neutral
Pin 3	Chan 2 Active	Pin 3	Chan 8 Active
Pin 4	Chan 2 Neutral	Pin 4	Chan 8 Neutral
Pin 5	Chan 3 Active	Pin 5	Chan 9 Active
Pin 6	Chan 3 Neutral	Pin 6	Chan 9 Neutral
Pin 7	Chan 4 Active	Pin 7	Chan 10 Active
Pin 8	Chan 4 Neutral	Pin 8	Chan 10 Neutral
Pin 9	Chan 5 Active	Pin 9	Chan 11 Active
Pin 10	Chan 5 Neutral	Pin 10	Chan 11 Neutral
Pin 11	Chan 6 Active	Pin 11	Chan 12 Active
Pin 12	Chan 6 Neutral	Pin 12	Chan 12 Neutral
Pin 13	Earth	Pin 13	Earth
Pin 14	Earth	Pin 14	Earth
Pin 15	Earth	Pin 15	Earth
Pin 16	Earth	Pin 16	Earth
Pin 17	Earth	Pin 17	Earth
Pin 18	Earth	Pin 18	Earth
Pin 19	Earth	Pin 19	Earth

10 Feature History

The new features added to APSX in each software release are listed below:

Release: v5.0 Date: August-2025

- APSX software is based on the APS-VI software which ended in v4.04. Hence APSX begins with v5.0.
- APSX includes a network connection for remote control and support for sACN and ArtNet.

11 Compliance Statements

The APSX from LSC Control Systems Pty Ltd meets all required CE (European), RCM (Australian) and UKCA (United Kingdom) standards.

CENELEC (European Committee for Electrotechnical Standardization).



Australian RCM (Regulatory Compliance Mark).



WEEE (Waste Electrical and Electronic Equipment).



The WEEE symbol indicates that the product should not be discarded as unsorted waste but must be sent to separate collection facilities for recovery and recycling.



For more information about how to recycle your LSC product, contact the dealer where you purchased the product or contact LSC via email at info@lsccontrol.com.au

You can also take any old electrical equipment to participating civic amenity sites (often known as 'household waste recycling centres') run by local councils. You can locate your closest participating recycling centre using the following links.

- AUSTRALIA <http://www.dropzone.org.au>.
- NEW ZEALAND <http://ewaste.org.nz/welcome/main>
- NORTH AMERICA <http://1800recycling.com>
- UK www.recycle-more.co.uk.

APSX

-END-