

ENGLISH

Image Spot 150 CW

V1

Product code: A0690110

Preface

Thank you for purchasing this Artecta product.

The purpose of this user manual is to provide instructions for the correct and safe use of this product.

Keep the user manual for future reference as it is an integral part of the product. The user manual shall be stored at an easily accessible location.

This user manual contains information concerning:

- Safety instructions
- Intended and non-intended use of the device
- Installation and operation of the device
- Maintenance procedures
- Troubleshooting
- Transport, storage and disposal of the device

Non-observance of the instructions in this user manual may result in serious injuries and damage of property.

©2023 Artecta. All rights reserved.

No part of this document may be copied, published or otherwise reproduced without the prior written consent of Highlite International.

Design and product specifications are subject to change without prior notice.

For the latest version of this document or other language versions, please visit our website www.highlite.com or contact us at service@highlite.com.

Highlite International and its authorized service providers are not liable for any injury, damage, direct or indirect loss, consequential or economic loss or any other loss arising from the use of, or inability to use or reliance on the information contained in this document.

Table of contents

1. Introduction	4
1.1. Before Using the Product	4
1.2. Intended Use	4
1.3. Product Lifespan	4
1.4. LEDs Lifespan	4
1.5. Text Conventions.....	5
1.6. Symbols and Signal Words	5
1.7. Symbols on the Information Label	5
2. Safety	6
2.1. Warnings and Safety Instructions	6
2.2. Requirements for the User	8
3. Description of the Device	9
3.1. Front View	9
3.2. Back View	9
3.3. Product Specifications	10
3.4. Optional Accessories.....	11
3.5. Dimensions	11
4. Installation	12
4.1. Safety Instructions for Installation	12
4.2. Personal Protective Equipment	12
4.3. Installation Site Requirements.....	12
4.4. Rigging	13
4.4.1. Angle Adjustment.....	14
4.5. Connecting to Power Supply	15
4.6. Power Linking of Multiple Devices.....	15
5. Setup	16
5.1. Warnings and Precautions.....	16
5.2. Stand-alone Setup	16
5.3. DMX Connection	16
5.3.1. DMX-512 Protocol	16
5.3.2. DMX Cables.....	17
5.3.3. Master/Slave Setup	17
5.3.4. DMX Linking	18
5.3.5. DMX Addressing.....	18
6. Operation	19
6.1. Safety Instructions for Operation.....	19
6.2. Control Mode	19
6.3. Control Panel.....	20
6.4. Start-up	20
6.5. Menu Overview	21
6.6. Main Menu Options	24
6.6.1. DMX Address	24
6.6.2. Person.....	24
6.6.3. Run Mode	25
6.6.4. Option	25
6.6.4.1. DMX Error	26
6.6.4.2. Display Key	26
6.6.4.3. Setting	26
6.6.4.4. Signal.....	27
6.6.5. Edit.....	28
6.6.6. Manual.....	29
6.6.6.1. Manual Test	30
6.6.6.2. Reset.....	30
6.6.7. Info.....	31
6.6.7.1. System Error	31

- 6.6.8. Service32
- 6.7. DMX Channels.....33
 - 6.7.1. 11, 14 Channels.....33
- 6.8. Rotating Gobo Wheel, Effect Wheel and Color Wheel35
 - 6.8.1. Replacing a Gobo from the Rotating Gobo Wheel36
 - 6.8.2. Gobo Size37
 - 6.8.3. Glass Gobo Orientation37
- 6.9. RDM Information38
 - 6.9.1. RDM Details38
 - 6.9.2. Supported RDM PIDs (Parameter IDs)38
 - 6.9.3. Highlite RDM Details38
- 7. Troubleshooting39**
- 8. Maintenance40**
 - 8.1. Safety Instructions for Maintenance40
 - 8.2. Preventive Maintenance40
 - 8.2.1. Basic Cleaning Instructions.....40
 - 8.2.2. Draining Condensation Water41
 - 8.3. Corrective Maintenance41
- 9. Deinstallation, Transportation and Storage42**
 - 9.1. Instructions for Deinstallation42
 - 9.2. Instructions for Transportation.....42
 - 9.3. Storage42
- 10. Disposal42**
- 11. Approval.....42**

1. Introduction

1.1. Before Using the Product



Important
Read and follow the instructions in this user manual before installing, operating or servicing this product.

The manufacturer will not accept liability for any resulting damages caused by the non-observance of this manual.

After unpacking, check the contents of the box. If any parts are missing or damaged, contact your Highlite International dealer.

Your shipment includes:

- Showtec Image Spot 150 CW
- Schuko to special 3-pin power cable (1,5 m)
- 3-pin XLR IN/OUT to special 3-pin data cable IP20 (0,2 m)
- Safety cable
- Safety eye
- User manual

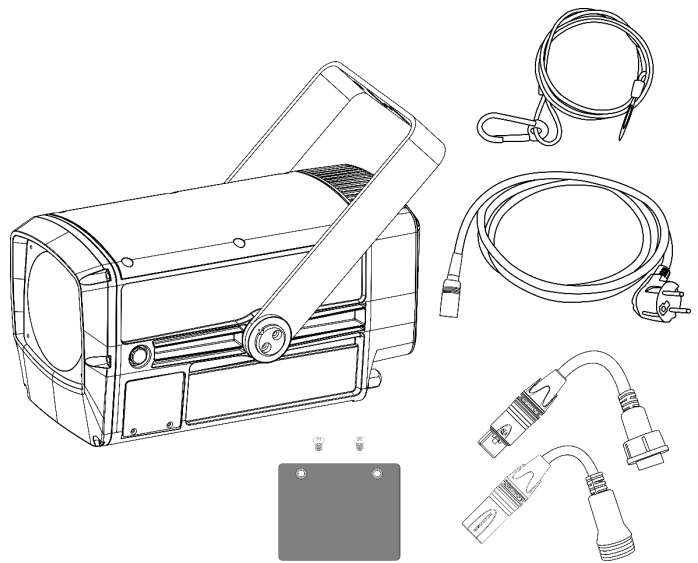

Fig. 01

1.2. Intended Use

This device is intended for professional use as an outdoor spot. It is not suitable for households and for general lighting.

Any other use, not mentioned under intended use, is regarded as non-intended and incorrect use.

1.3. Product Lifespan

This device is not designed for permanent operation. Disconnect the device from the electrical power supply when the device is not in operation. This will reduce the wear and will improve the device's lifespan.

1.4. LEDs Lifespan

The light output of the LEDs gradually decreases over time (lumen depreciation). High operating temperatures contribute to this process. You can extend the lifespan of the LEDs by providing adequate ventilation and operating the LEDs at the lowest possible brightness.

1.5. Text Conventions

Throughout the user manual the following text conventions are used:

- Buttons: All buttons are in bold lettering, for example “Press the **UP/DOWN** buttons”
- References: References to chapters and parts of the device are in bold lettering, for example: “Refer to **2. Safety**”, “turn the **adjustment screw (02)**”
- 0–255: Defines a range of values
- Notes: **Note:** (in bold lettering) is followed by useful information or tips

1.6. Symbols and Signal Words

Safety notes and warnings are indicated throughout the user manual by safety signs.

Always follow the instructions provided in this user manual.



DANGER

Indicates an imminently hazardous situation which, if not avoided, will result in death or serious injury.



WARNING

Indicates a potentially hazardous situation which, if not avoided, could result in death or serious injury.



CAUTION

Indicates a potentially hazardous situation, which, if not avoided, may result in minor or moderate injury.



Attention

Indicates important information for the correct operation and use of the product.



Important

Read and observe the instructions in this document.



Electrical hazard



Provides important information about the disposal of this product.

1.7. Symbols on the Information Label

This product is provided with an information label. The information label is located on the backside of the device.

The information label contains the following symbols:



This device shall not be treated as household waste.

IP66

This device is rated IP66.



This device falls under IEC protection class I.

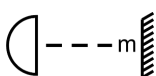

Minimum distance from lighted objects.

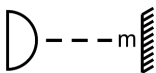

Minimum distance from other objects.

2. Safety



Important

Read and follow the instructions in this user manual before installing, operating or servicing this product.

The manufacturer will not accept liability for any resulting damages caused by the non-observance of this manual.

2.1. Warnings and Safety Instructions



DANGER

Danger for children

For adult use only. The device must be installed beyond the reach of children.

- Do not leave various parts of the packaging (plastic bags, polystyrene foam, nails, etc.) within children's reach. Packaging material is a potential source of danger for children.



DANGER

Electric shock caused by dangerous voltage inside

There are areas within the device where dangerous touch voltage may be present.

- Do not open the device or remove any covers.
- Do not operate the device if the covers or the housing are open. Before operation, check if the housing is firmly closed and all screws are tightly fastened.
- Disconnect the device from electrical power supply before service and maintenance, and when the device is not in use.



DANGER

Electric shock caused by short-circuit

This device falls under IEC protection class I.

- Make sure that the device is electrically connected to ground (earth). Connect the device only to a socket-outlet with ground (earth) connection.
- Do not cover the ground (earth) connection.
- Do not bypass the thermostatic switch or fuses.
- Do not let the power cable come into contact with other cables. Handle the power cable and all connections with the mains with caution.
- Do not modify, bend, mechanically strain, put pressure on, pull or heat up the power cable.
- Make sure that the power cable is not crimped or damaged. Examine the power cable periodically for any defects.
- Do not immerse the device in water or other liquids. Do not install the device in a location where flooding may occur.
- Do not use the device during thunderstorms. Disconnect the device from the electrical power supply immediately.
- Keep the connectors sealed with the rubber caps when the connectors are not in use.
- Do not connect the cables from above the connectors, if the device is installed outdoors. Make a 'drip loop' in the cable so that rain water cannot enter the device.

- Make sure that the cable run is not too heavy. A heavy cable run can cause damage to the connectors. If the connectors are damaged, their ingress protection (IP) can deteriorate.



WARNING
Risk of epileptic shock

Strobe lighting can trigger seizures in photosensitive epilepsy. Sensitive persons should avoid looking at strobe lights.



Attention
Power supply

- Before connecting the device to the power supply, make sure that the current, voltage and frequency match the input voltage, current and frequency specified on the information label on the device.
- Make sure that the cross-sectional area of the extension cords and power cables is sufficient for the required power consumption of the device.



Attention
General safety

- Do not connect the device to a dimmer pack.
- Do not switch the device on and off in short intervals. This decreases the device's life.
- Do not shake the device. Avoid brute force when installing or operating the device.
- Change the lens or the LEDs if they are visibly damaged to such an extent that their effectiveness is impaired, for example by cracks or deep scratches. Contact your Highlite International dealer for more information, as servicing can be performed only by instructed or skilled persons.
- If the device is dropped or struck, disconnect the device from the electrical power supply immediately.
- If the device is exposed to extreme temperature variations (e.g. after transportation), do not switch it on immediately. Let the device reach room temperature before switching it on, otherwise it may be damaged by the formed condensation.
- If the device fails to work properly, discontinue the use immediately.



Attention
For professional use only
This device shall be used only for the purposes it is designed for.

This device is designed to be used as an outdoor spot. Any incorrect use may lead to hazardous situations and result in injuries and material damage.

- This device is not suitable for households and for general lighting.
- This device is not designed for permanent operation.
- This device contains a non-user-replaceable light source.
- This device does not contain user-serviceable parts. Unauthorized modifications to the device will render the warranty void. Such modifications may result in injuries and material damage.

**Attention**

Before each use, examine the device visually for any defects.

Make sure that:

- All screws used for installing the device or parts of the device are tightly fastened and are not corroded.
- The safety devices are not damaged.
- There are no deformations on housings, fixations and installation points.
- The lens is not cracked or damaged.
- The power cables are not damaged and do not show any material fatigue.

**Attention**

Do not expose the device to conditions that exceed the rated IP class conditions.

This device is IP66 rated. IP (Ingress Protection) 66 class means that the device is dust-tight and protected against harmful effect of powerful water jets or of heavy seas.

2.2. Requirements for the User

This product may be used by ordinary persons. Maintenance may be carried by ordinary persons. Installation and service shall be carried out only by instructed or skilled persons. Contact your Highlite dealer for more information.

Instructed persons have been instructed and trained by a skilled person, or are supervised by a skilled person, for specific tasks and work activities associated with the installation, service and maintenance of this product, so that they can identify risks and take precautions to avoid them.

Skilled persons have training or experience, which enables them to recognize risks and to avoid hazards associated with the installation, service and maintenance of this product.

Ordinary persons are all persons other than instructed persons and skilled persons. Ordinary persons include not only users of the product but also any other persons that may have access to the device or who may be in the vicinity of the device.

3. Description of the Device

The Artecta Image Spot 150 CW is a 150 Watt gobo projector spot in an IP66 die-cast aluminium housing, suitable for indoor and outdoor applications. It has 4 bi-directional gobos + open and a color wheel with 5 colors + open. A 4-facet bi-rotational prism with speed control and a frost filter allow you to create colorful dynamic effects. It has Focus and Zoom (20° to 40°) and multiple scenes can be programmed and played back via a sequence or programme for stand-alone use. The Image Spot 150 CW can be controlled via DMX and is RDM compatible.

3.1. Front View

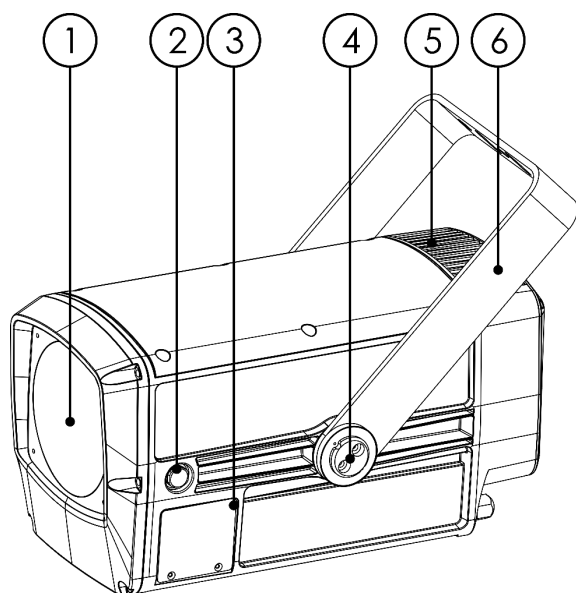

- 01) 150 W LED
- 02) Protective vent
- 03) Protective metal plate for LED display+ menu buttons
- 04) Adjustment screw
- 05) Ventilation
- 06) Mounting bracket

Fig. 02

3.2. Back View

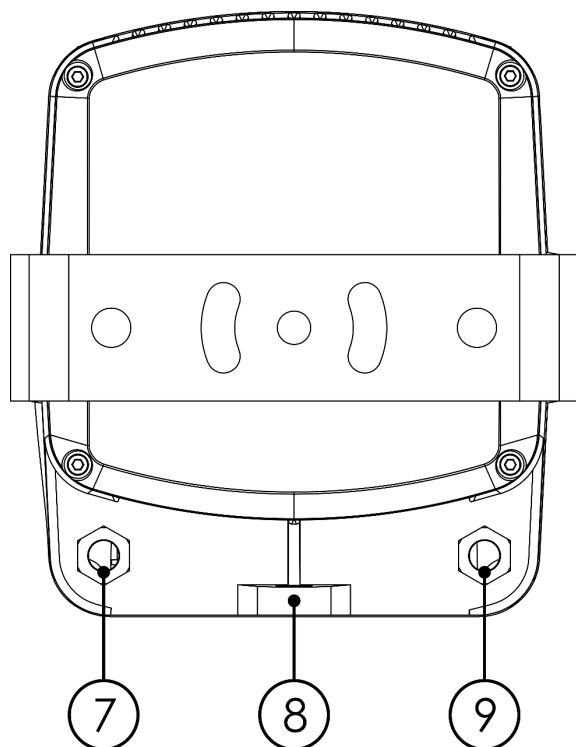

- 07) Special 3-pin IP68 DMX signal connector IN/Out
- 08) Safety eye
- 09) IP68 power IN

Fig. 03

3.3. Product Specifications

Model:	Image Spot 150 CW
Electrical:	
Input voltage:	100–240 V AC, 50/60 Hz
Power consumption:	170 W
Physical:	
Dimensions:	454 x 206 x 201 mm (LxWxH)
Weight:	9,36 kg
Optics:	
Light source:	150W CW LED
Dimmer:	0–100 %
Strobe:	0–25 Hz
Gobo	4 x Glass gobo: Diameter 28,79 mm, image size 22,32 mm, thickness 1,1 mm
Beam angle (circular):	20°–40°
	Zoom
	Focus
	Effect wheel
	4-facet rotational prism
	4 gobos + open
Operation and control:	
Control:	Stand-alone (auto, edit 1, edit2) Master/Slave (auto, edit 1, edit2) DMX-512, RDM
DMX channels:	11, 14 channels
Control panel:	LED display
Connections:	
Power connection:	Dedicated IP68 Power connector IN
Data connections:	Dedicated IP68 3-pin DMX connectors IN/OUT
Signal pinouts:	3-pin: pin 1 (ground), pin 2 (-), pin 3 (+)
Construction:	
Housing:	ABS / Aluminum
Color:	Light grey
IP rating:	IP66
Cooling:	Convection/axial fan
Thermal:	
Maximum ambient temperature t_a :	45 °C
Minimum operating temperature	-20 °C
Minimum distance:	
Minimum distance from flammable surfaces:	0,5 m
Minimum distance to lighted object:	0,8 m

3.4. Optional Accessories

The Image Spot 150 CW is delivered with accessories. You can additionally purchase the following accessories:

- Product code: [43600](#) IP65 Power Extension cable 1,5 m
- Product code: [43601](#) IP65 Power Extension cable 5 m
- Product code: [43602](#) IP65 Power Extension cable 10 m
- Product code: [43610](#) IP65 Data Extension cable 1,5 m
- Product code: [43611](#) IP65 Data Extension cable 5 m
- Product code: [43612](#) IP65 Data Extension cable 10 m

3.5. Dimensions

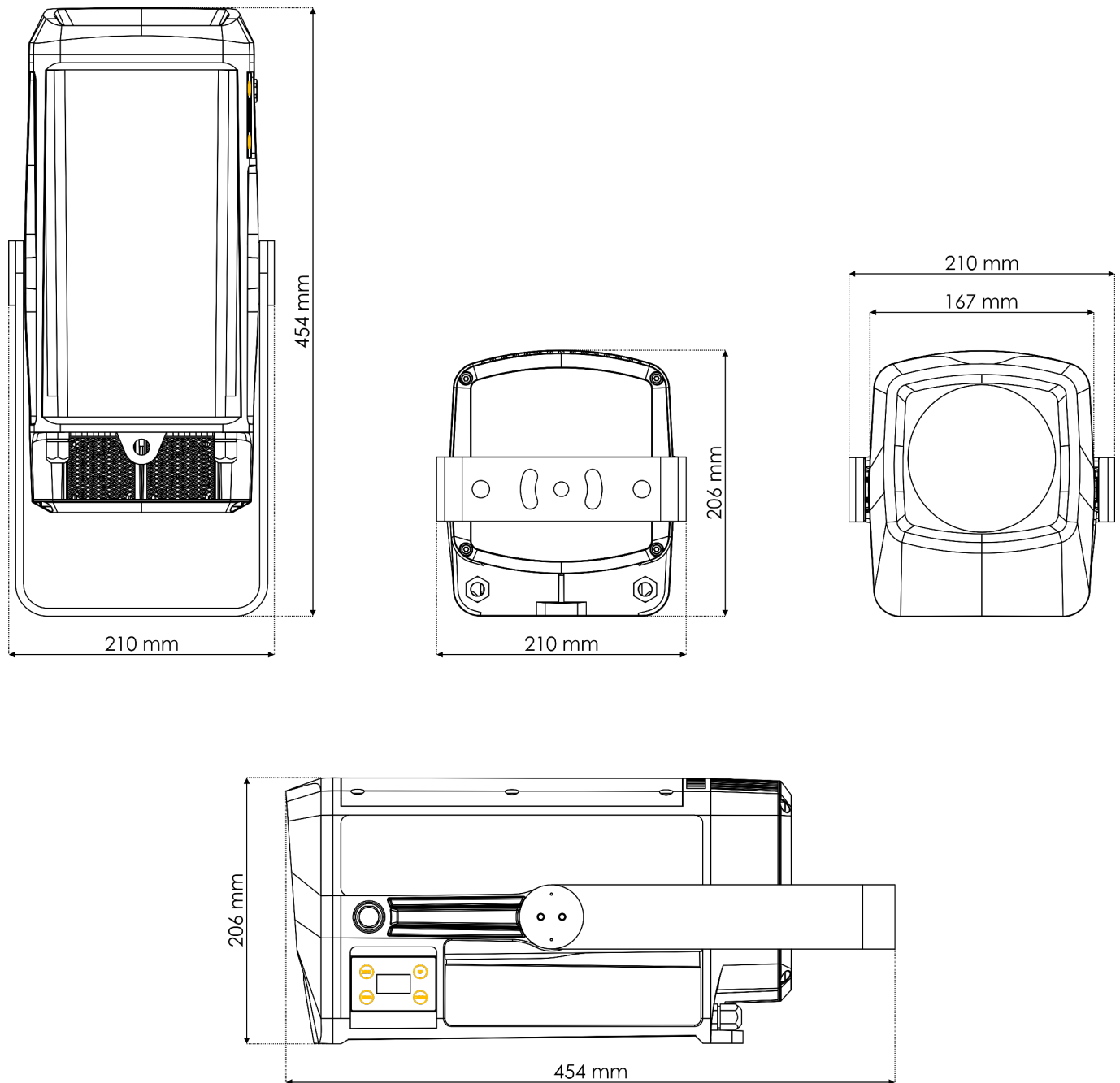

Fig. 04

4. Installation

4.1. Safety Instructions for Installation



WARNING

Incorrect installation can cause serious injuries and damage of property.

If trussing systems are used, installation must be carried out only by instructed or skilled persons.

Follow all applicable European, national and local safety regulations concerning rigging and trussing.

4.2. Personal Protective Equipment

During installation and rigging wear personal protective equipment in compliance with the national and site-specific regulations.

4.3. Installation Site Requirements

- The device can be used outdoors.
- The device can be mounted to a truss or other rigging structure in any orientation.
- The minimum distance to other objects must be bigger than 0,5 m.
- The minimum distance between the light output and the illuminated surface must be bigger than 0,8 m.
- The maximum ambient temperature $t_a = 45\text{ °C}$ must never be exceeded.
- The relative humidity must not exceed 50 % with an ambient temperature of 45 °C .

4.4. Rigging

The device can be positioned on a flat surface or mounted to a truss or other rigging structure in any orientation. Make sure that all loads are within the pre-determined limits of the supporting structure.



CAUTION

Restrict the access under the work area during rigging and/or derigging.

To mount the device, follow the steps below:

- 01) Use a clamp to attach the device to the supporting structure, as shown in Fig. 05. Make sure that the device cannot move freely.

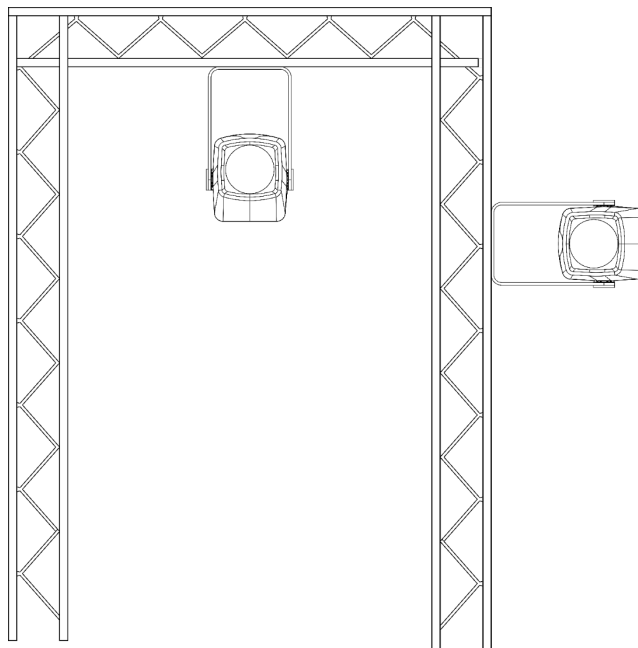

Fig. 05

- 02) Secure the device with a secondary suspension, for example a safety cable. Make sure that the secondary suspension can hold 10 times the weight of the device. If possible, the secondary suspension should be attached to a supporting structure independent of the primary suspension.
- 03) Put the safety cable through the safety eye, as shown in Fig. 06.

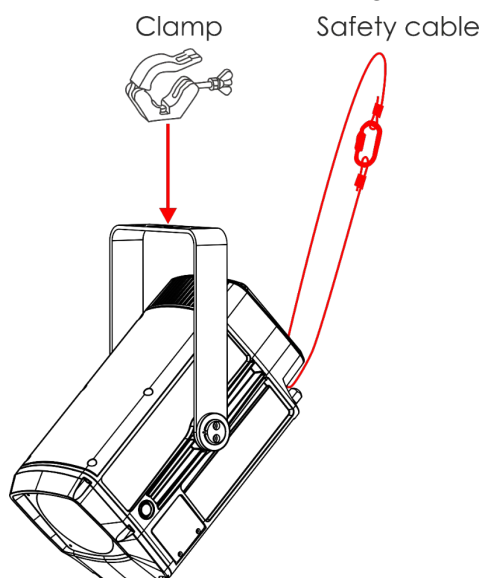

Fig. 06

4.4.1. Angle Adjustment

You can adjust the angle of the device with the **adjustment screw (04)**.

- 01) Turn the **adjustment screw (04)** counterclockwise to release it.
- 02) Tilt the device to the desired angle (see Fig. 07).
- 03) Turn the **adjustment screw (04)** clockwise to tighten it. Make sure that the device cannot move freely after the **adjustment screw (04)** is tightened.

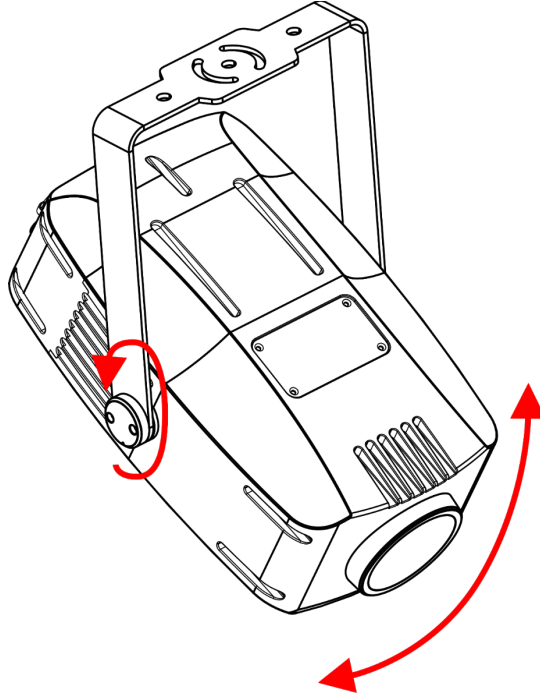

Fig. 07

4.5. Connecting to Power Supply



DANGER
Electric shock caused by short-circuit

The device accepts AC mains power at 100–240 V and 50/60 Hz. Do not supply power at any other voltage or frequency to the device.

This device falls under IEC protection class I. Make sure that the device is always electrically connected to the ground (earth).

Before connecting the device to the socket-outlet:

- Make sure that the power supply matches the input voltage specified on the information label on the device.
- Make sure that the socket-outlet has ground (earth) connection.

Connect the device to the socket-outlet with the power plug. Do not connect the device to a dimmer circuit, as this may damage the device.

This device is IP66 rated.

- Do not expose the device to conditions that exceed the rated IP class conditions.
- Keep the connectors sealed with the rubber caps when the connectors are not in use.
- Do not connect the cables from above the connectors, if the device is installed outdoors. Make a 'drip loop' in the cable so that rain water cannot enter the device.
- Make sure that the cable run is not too heavy. A heavy cable run can cause damage to the connectors. If the connectors are damaged, their ingress protection (IP) can deteriorate.

4.6. Power Linking of Multiple Devices

This device supports power linking. Power can be relayed to another device via the power OUT connector. Note that the input and the output connectors have different designs: one type cannot be connected to the other.

Power linking of multiple devices must be carried out only by instructed or skilled persons.



WARNING
Incorrect power linking may lead to overload of the electrical circuit and result in serious injuries and damage of property.

To prevent overload of the electrical circuit, when power linking multiple devices:

- Use cables with sufficient current-carrying capacity. The power cable supplied with the device is not suitable for power linking of multiple devices.
- Make sure that the total current draw of the device and all connected devices does not exceed the rated capacity of the power cables and the circuit breaker.
- Do not link more devices on one power link than the maximum recommended number.

Maximum recommended number of devices:

- at 100–120 V: 6 devices Image Spot 150 CW
- at 200–240 V: 12 devices Image Spot 150 CW

5. Setup

5.1. Warnings and Precautions



Attention

Connect all data cables before supplying power.

Disconnect power supply before connecting or disconnecting data cables.

5.2. Stand-alone Setup

When the Image Spot 150 CW is not connected to a controller or to other devices, it functions as a stand-alone device. It can be operated in auto mode or manually.

For more information about the control modes, refer to **6.6.3. Run Mode** on page 25 or **6.6.5. Edit** on page 28.

5.3. DMX Connection

5.3.1. DMX-512 Protocol

You need a DMX serial data link to run light shows of one or more devices using a DMX-512 controller or to run synchronized shows of two or more devices set in a master/slave operating mode.

The Image Spot 150 CW has 3-pin DMX signal IN and OUT connectors.

The pin assignment is as follows:

- 3-pin: pin 1 (ground), pin 2 (-), pin 3 (+)

Devices on a serial data link must be daisy-chained in a single line. The number of devices that you can control on one data link is limited by the combined number of the DMX channels of the connected devices and the 512 channels available in one DMX universe.

To comply with the TIA-485 standard, no more than 32 devices should be connected on one data link. In order to connect more than 32 devices on one data link, you must use a DMX optically isolated splitter/booster, otherwise this may result in deterioration of the DMX signal.

Note:

- Maximum recommended DMX data link distance: 300 m
- Maximum recommended number of devices on a DMX data link: 32 devices

5.3.2. DMX Cables

Shielded twisted-pair cables with 3-pin XLR connectors must be used for reliable DMX connection. You can purchase DMX cables directly from your Highlite International dealer or make your own cables.

If you use 3-pin XLR audio cables for DMX data transmission, this may lead to signal degradation and unreliable operation of the DMX network.

When you make your own DMX cables, make sure that you connect the pins and wires correctly as shown in Fig. 08.

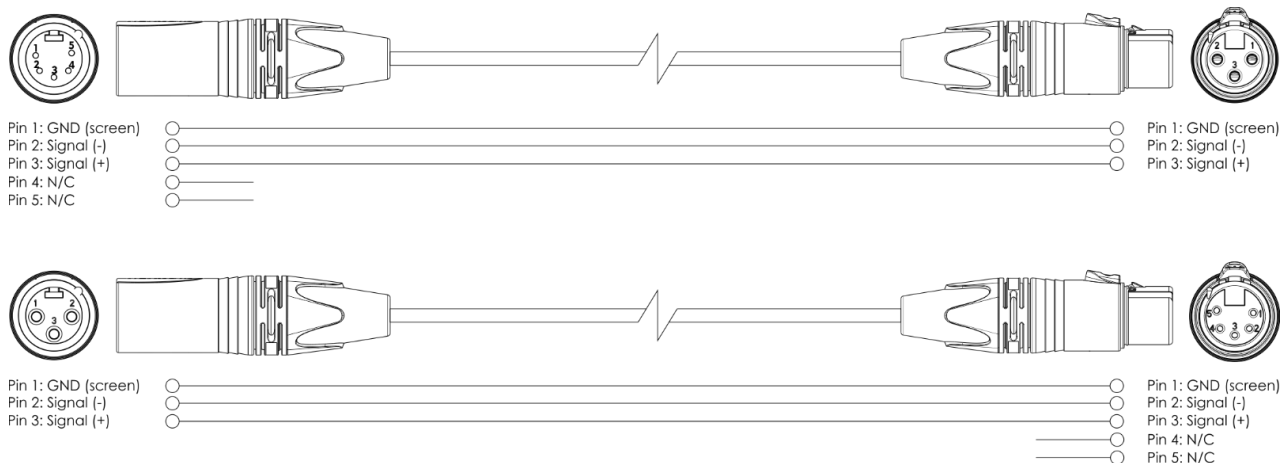

Fig. 08

5.3.3. Master/Slave Setup

The Image Spot 150 CW supports master/slave control mode. To connect multiple devices in master/slave setup, follow the steps below:

- 01) Connect the first device's DMX OUT connector to the second device's DMX IN connector.
- 02) Repeat step 1 to connect all devices as shown in Fig. 09.
- 03) Connect a DMX terminator (120 Ω resistor) to the DMX OUT connector of the last device in the setup.
- 04) Set the first device on the data link as a master device. See **6.6.3. Run Mode** on page 25 or **6.6.5. Edit** on page 28 for more information.
- 05) Set the remaining devices to slave mode. See **6.6.3. Run Mode** on page 25 or **6.6.5. Edit** on page 28 for more information.

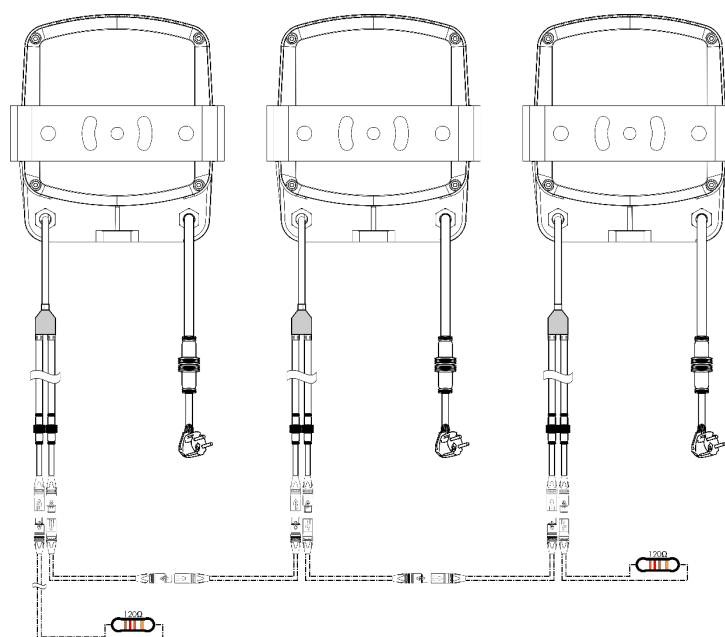

Fig. 09

5.3.4. DMX Linking

To connect multiple devices on one DMX data link, follow the steps below:

- 01) Use the supplied 3-pin XLR to special 3-pin data cable to connect the DMX OUT connector of the lighting controller to the DMX IN connector of the first device.
- 02) Connect the first device's DMX OUT connector to the second device's DMX IN connector.
- 03) Repeat step 2 to connect all devices in a daisy-chain as shown in Fig. 10.
- 04) Connect a DMX terminator (120 Ω resistor) to the DMX OUT connector of the last device on the data link.

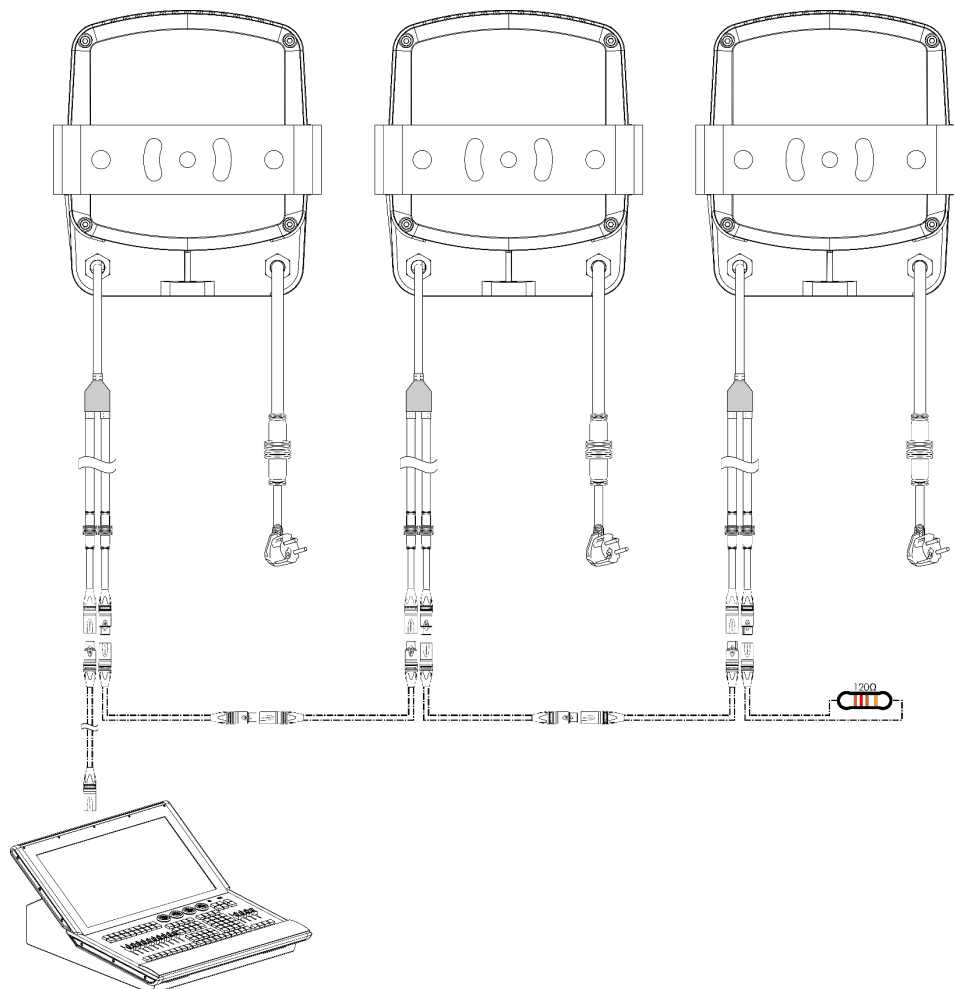

Fig. 10

5.3.5. DMX Addressing

In a setup with multiple devices, make sure that you set the DMX starting address of each device correctly. The Image Spot 150 CW has 2 personalities: 11 and 14 channels.

If you want to connect multiple devices on one data link and use them in 14-channel mode, for example, follow the steps below:

- 01) Set the starting address of the 1st device on the data link to 1 (001).
- 02) Set the starting address of the 2nd device on the data link to 15 (015), as $1 + 14 = 15$.
- 03) Set the starting address of the 3rd device on the data link to 29 (029) as $15 + 14 = 29$.
- 04) Continue assigning the starting addresses of the remaining devices by adding each time 14 to the previous number.

Make sure that you do not have any overlapping channels in order to control each Image Spot 150 CW correctly. If two or more devices are addressed similarly, they will work similarly.

6. Operation

6.1. Safety Instructions for Operation



Attention

This device must be used only for the purposes it is designed for.

This device is intended for professional use as an outdoor spot. It is not suitable for households and for general lighting.

Any other use, not mentioned under intended use, is regarded as non-intended and incorrect use.



Attention

Power supply

Before connecting the device to the power supply, make sure that the current, voltage and frequency match the input voltage, current and frequency specified on the information label on the device.

6.2. Control Mode

The Image Spot 150 CW supports the following control modes:

- Stand-alone: Auto, edit 1, edit2
- Master/Slave: Auto, edit 1, edit2
- DMX-512 11, 14 channels

For more information about how to connect the devices, refer to **5. Setup** on pages 16–18.

To operate the device manually as a stand-alone device or in a master/slave setup:

See **6.6.3. Run Mode** on page 25 or **6.6.5. Edit** on page 28 for more information

In auto mode you can run the auto program. To run the auto program:

See **6.6.3. Run Mode** on page 25 for more information.

To operate the device with a DMX controller:

- Set the DMX starting address of the device in the DMX Address menu. See **5.3.5. DMX Addressing** on page 18 and **6.6.1. DMX Address** on page 24.
- Select the DMX channel mode. See **6.6.1. DMX Address** on page 24 for more information. See **6.7. DMX Channels** on pages 33–34 for complete overview of all DMX channels.

6.3. Control Panel

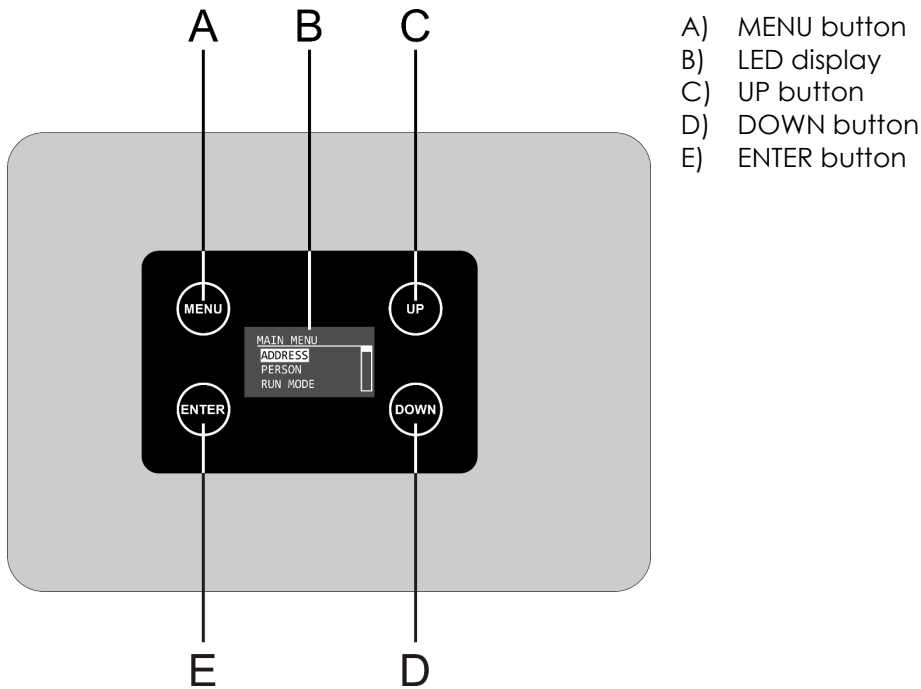

Fig. 11

- Use the **MENU** function in each menu to exit the current submenu and to return to the Main Menu.
- Use the **ENTER** button to open the desired menu, to confirm your choice or to set the currently selected value.
- Use the **UP/DOWN** buttons to navigate through the menus or to increase/decrease numeric values.

6.4. Start-up

Upon start-up the display shows a splash screen with the brand name of this device. Immediately afterwards the display shows the start screen. The start screen provides information about the currently active operation mode and temperature. Press the **MENU** button to enter the main menu. The display shows:



Note:

When no button is pressed after 10 seconds of inactivity, the display turns off.

To light up the display, you have to press the MENU button for 3 seconds. Once you have pressed this button, the display lights up.

6.5. Menu Overview

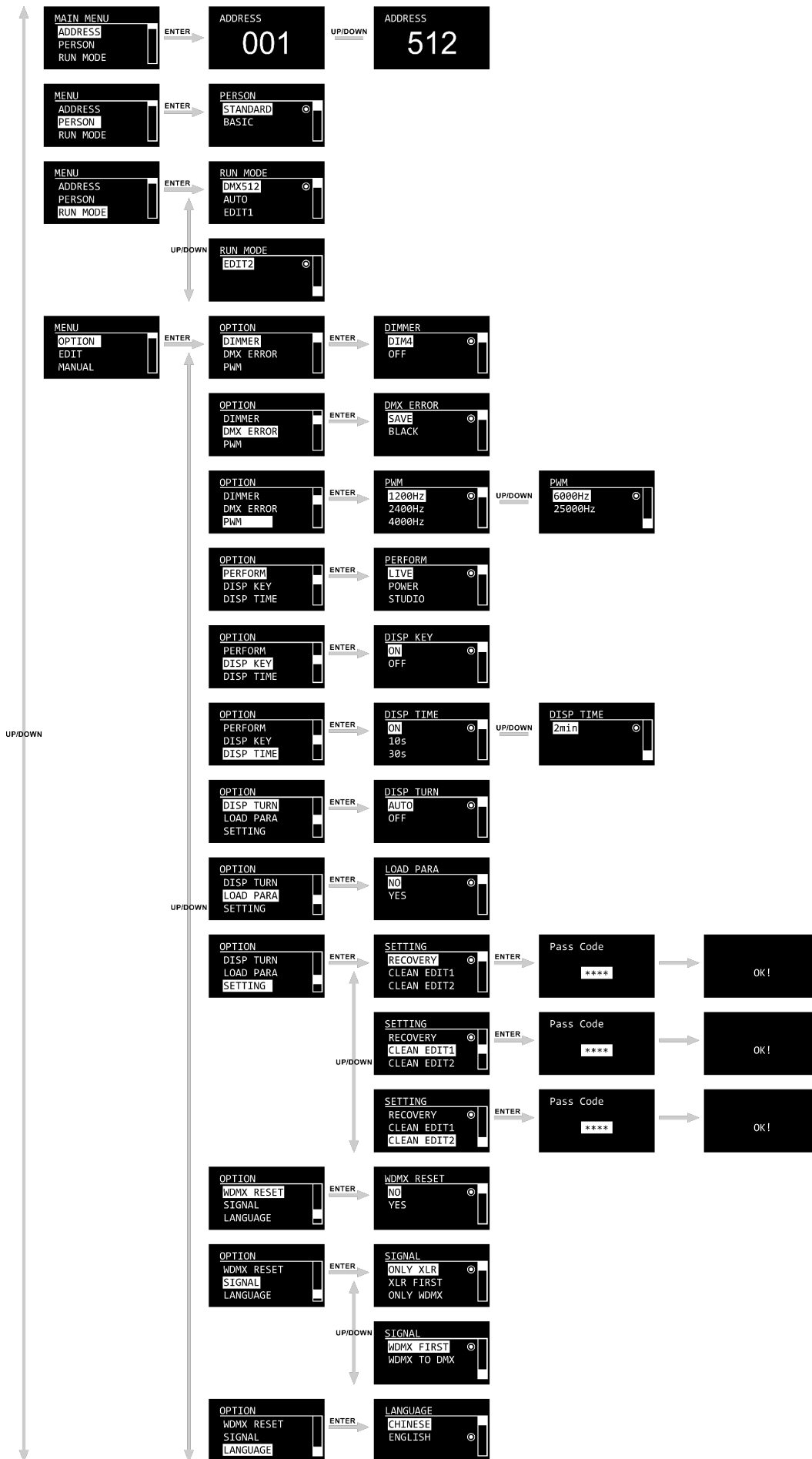

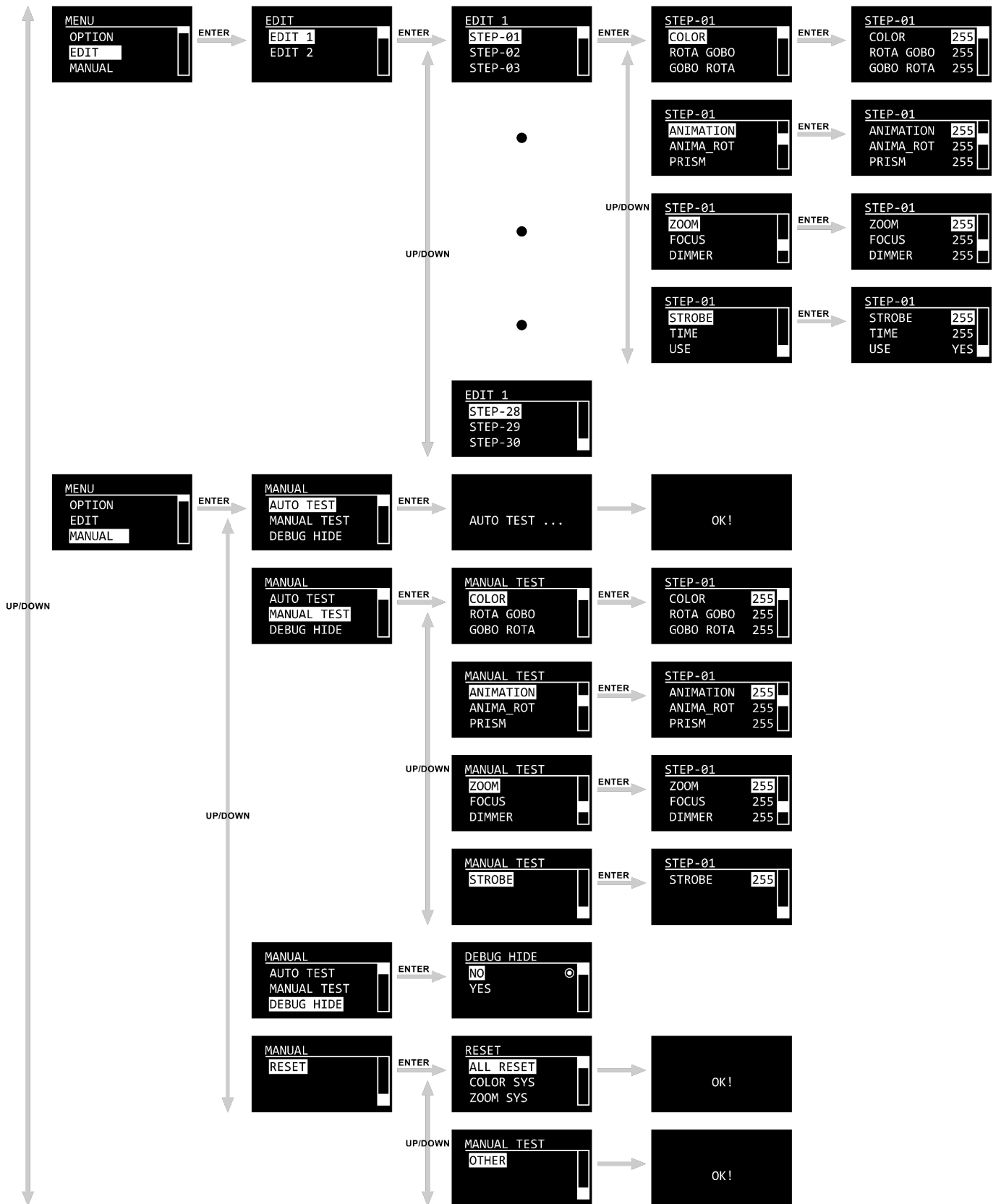

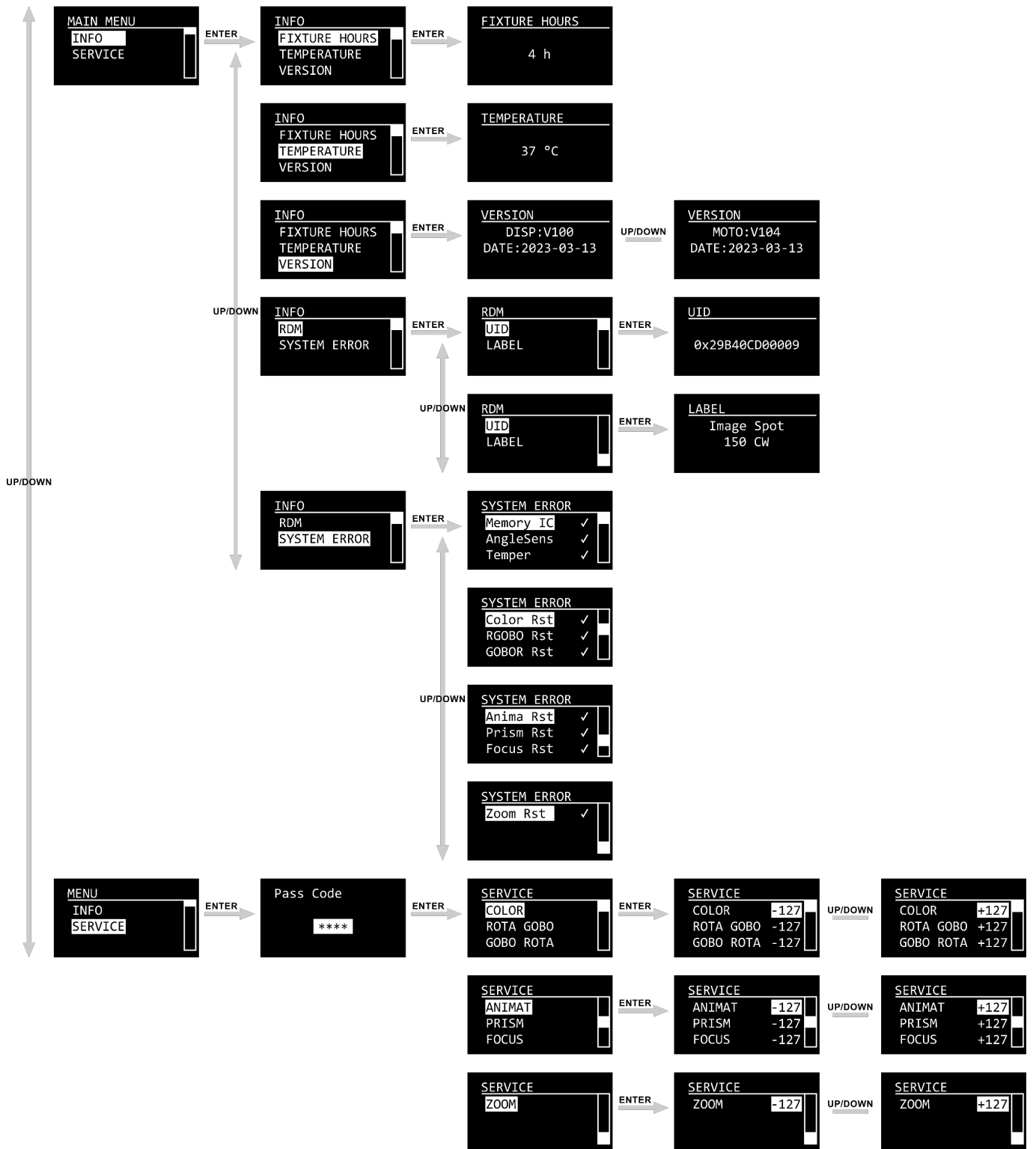

6.6. Main Menu Options

The main menu has the following options:

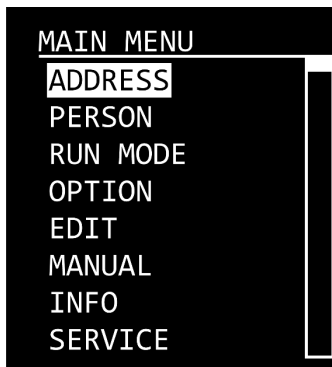

- 01) Press the **MENU** button to open the main menu.
- 02) Press the **UP/DOWN** buttons to navigate through the main menu.
 - Address: See **6.6.1. DMX Address**
 - Person: See **6.6.2. Person**
 - Run Mode See **6.6.3. Run Mode**
 - Option: See **6.6.4. Option**
 - Edit: See **6.6.5. Edit**
 - Manual: See **6.6.6. Manual**
 - Info: See **6.6.7. Info**
 - Service: See **6.6.8. System Error**
- 03) Press the **ENTER** button to open the submenus.

6.6.1. DMX Address

In this menu you can set the DMX starting address of the device and the personality of this device.

- 01) Press the **UP/DOWN** buttons to select the DMX starting address of the device. The selection range is 001–512. Refer to **5.3.5. DMX Addressing** on page 18 for more information.
- 02) Press the **ENTER** button to confirm.

6.6.2. Person

In this menu you can select the DMX channel mode.

- 01) Press the **UP/DOWN** buttons to select the DMX channel mode. There are 2 options available:



- Standard: 11-channel mode
 - Basic: 14-channel mode
- 02) Press the **ENTER** button to confirm.

6.6.3. Run Mode

In this menu you can select the desired operating mode.

01) Press the **UP/DOWN** buttons to select the run mode. There are 4 options available:

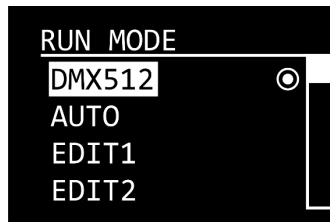

- DMX512: DMX mode
- Auto: Built-in programs
- Edit1: Custom Program Edit 1 is active, steps 1–30
- Edit2: Custom Program Edit 2 is active, steps 1–30

02) Press the **ENTER** button to confirm.

6.6.4. Option

In this menu, you can adjust the settings of the device. This menu requires a password.

01) Press the **UP/DOWN** buttons to select one of the following 12 options:

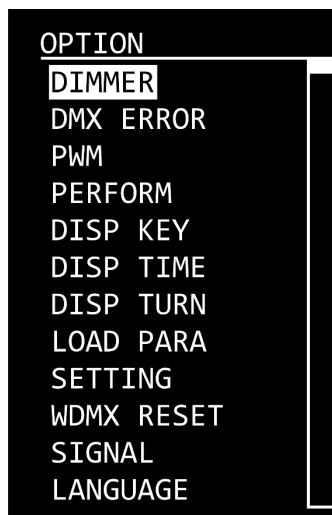

- DIMMER: Set the dimmer speed. The available options are OFF or DIM4
- DMX ERROR: See **6.6.4.1. DMX Error**
- PWM: Set the PWM (Pulse Width Modulation) frequency. The available options are 1200 Hz, 2400 Hz, 4000 Hz, 6000 Hz and 25000 Hz
- PERFORM: Set the speed of the cooling fans: LIVE (auto), STUDIO (slow), POWER (fast)
- DISP KEY: See **6.6.4.2. Disp Key**
- DISP TIME: After a set period of inactivity, the display turns off. The period of time can be set to one of the following options: ON, 10s, 30s, 2min
- DISP TURN: The LED display will be inverted 180° (AUTO/OFF)
- LOAD PARA: Upload the parameters of Custom Program 1 and/or 2 (EDIT1 or EDIT2) from the master device to the slave device(s)
- SETTING: See **6.6.4.3. Settings** for more information
- WDMX RESET: Reset the wireless connection and clear all messages of the receiver (NO/YES)
- SIGNAL: See **6.6.4.4. Signal** for more information
- LANGUAGE: Set the language of the display. The available options are English or Chinese

02) Press the **ENTER** button to confirm.

6.6.4.1. DMX Error

In this submenu you can determine the behavior of the device in case of a DMX failure.

- 01) Press the **UP/DOWN** buttons select one of the following 2 options:
- **SAVE:** The device will use the last properly received DMX signal
 - **BLACK:** The device will black out the light output
- 02) Press the **ENTER** button to confirm.

6.6.4.2. Display Key

In this submenu you can activate the display keylock.

- 01) Press the **UP/DOWN** buttons to toggle between ON and OFF.
- **ON:** The display lock is on. The display will be locked after 30 seconds of inactivity. After 5 more seconds the display will turn off. To access the main menu, you need to enter the password. The default password is pressing the **UP/DOWN** buttons in the following order: **UP, DOWN, UP, DOWN**, then press **ENTER**
 - **OFF:** The access to the main menu remains unlocked after the display turns off
- 02) Press the **ENTER** button to confirm.

Note:

If you turn off the display lock, this will not affect the submenus which by default require a password.

6.6.4.3. Setting

In this submenu you can reset some of the parameters of the device.

- 01) Press the **UP/DOWN** buttons to select one of the following 3 options:

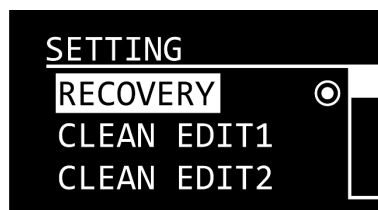

- **RECOVERY:** Restore the default factory settings of the device. This submenu requires a password. The default password is pressing the **UP/DOWN** buttons in the following order: **UP, DOWN, UP, DOWN**, then press **ENTER**
 - **CLEAN EDIT1:** Reset Custom Program 1. All values set in EDIT 1 will be cleared. See **6.6.5. Edit** on pages 28–29 for more information. This submenu requires a password. The default password is pressing the **UP/DOWN** buttons in the following order: **UP, DOWN, UP, DOWN**, then press **ENTER**
 - **CLEAN EDIT2:** Reset Custom Program 2. All values set in EDIT 2 will be cleared. See **6.6.5. Edit** on pages 28–29 for more information. This submenu requires a password. The default password is pressing the **UP/DOWN** buttons in the following order: **UP, DOWN, UP, DOWN**, then press **ENTER**
- 02) Press the **ENTER** button to confirm.

6.6.4.4. Signal

In this submenu you can set the signal preferences when wireless DMX is enabled.

01) Press the **UP/DOWN** buttons to select one of the following 5 options:



- **ONLY XLR:** DMX signal is only received via wired XLR cable
- **XLR FIRST:** DMX signal is received via wired XLR cable (1st priority). When DMX signal is lost, the device will keep playing via WDMX (2nd priority). The device must be paired with WDMX
- **ONLY WDMX:** DMX signal is only received via Wireless DMX. Device needs to be paired via WDMX
- **WDMX FIRST:** DMX signal is received via WDMX (1st priority). The device must be paired with WDMX. When DMX signal is lost, the device will keep playing via wired XLR cable (2nd priority)
- **WDMX TO WDMX:** WDMX signal is received via WDMX. When linking multiple devices, you can set a wireless connection between the first device and the lighting controller and link the rest of the devices to the first device via WDMX

02) Press the **ENTER** button to confirm.

6.6.5. Edit

In this menu you can edit the 2 custom programs.



To edit the custom programs:

- 01) Press the **UP/DOWN** buttons to select the custom program you want to edit: EDIT1 or EDIT2.
- 02) Press the **ENTER** button to confirm and open the submenu with the scenes. Each custom program has 30 scenes, which can be edited:

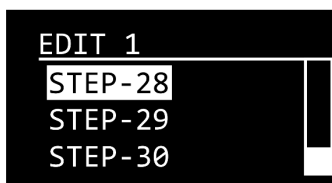
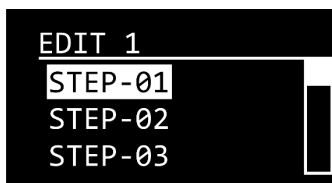

- 03) Press the **UP/DOWN** buttons to select the desired scene.
- 04) Press the **ENTER** button to confirm and open the submenu with the settings for the respective scene.
- 05) Press the **UP/DOWN** buttons to select one of the following 12 options:

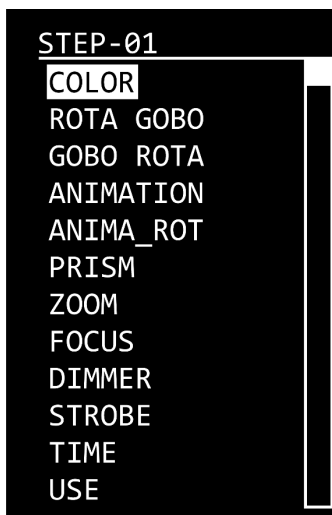

- COLOR: Set the position of the color wheel. The adjustment range is 0–255
- ROTA GOBO: Set the position of the gobo wheel. The adjustment range is 0–255
- GOBO ROTA: Set the rotation speed of the gobo wheel. The adjustment range is 0–255
- ANIMATION: Set the position of the effect wheel. The adjustment range is 0–255
- ANIMA_ROT: Set the rotation speed of the effect wheel. The adjustment range is 0–255
- PRISM: Set the rotation speed of the prism. The adjustment range is 0–255
- ZOOM: Set the zoom adjustment. The adjustment range is 0–255

- **FOCUS:** Set the focus adjustment. The adjustment range is 0–255
- **DIMMER:** Set the intensity of the dimmer. The adjustment range is 0–255, from low to high intensity
- **STROBE:** Add strobe effect. The adjustment range is 0–25, from OFF to high frequency
- **TIME:** Set the duration of the step (0–255, from 0,1 to approximately 25 seconds)
- **USE:** Include the step in the custom program (YES/NO). If you select NO, the step will be excluded from the playback of the custom program

- 06) Press the **ENTER** button to confirm.
- 07) Press the **UP/DOWN** buttons to increase/decrease the values.
- 08) Press the **ENTER** button to set the value and to move to the next setting.
- 09) Repeat steps 7–8 to set all parameters in the scene.
- 10) Press the **MENU** button to return to the submenu with the steps.
- 11) Repeat steps 3–9 to edit the remaining steps of the selected custom program.

Note:

For each custom program you can create 30 steps, which makes it possible to create 60 customized scenes in total.

6.6.6. Manual

In this menu you can manually adjust and reset the parameters of the device.

- 01) Press the **UP/DOWN** buttons to select one of the following 4 options:

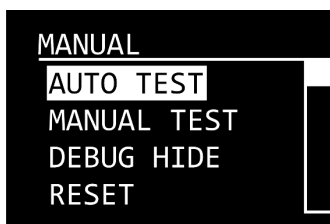

- **AUTO TEST:** Perform auto test of parameters of the device
 - **MANUAL TEST:** See **6.6.6.1. Manual Test**
 - **DEBUG HIDE:** This option is not relevant to the use and operation of the device
 - **RESET:** See **6.6.6.2. Reset**
- 02) Press the **ENTER** button to confirm.

6.6.6.1. Manual Test

In this submenu you can manually adjust the parameters of the device.

01) Press the **UP/DOWN** buttons to select one of the following 10 options:

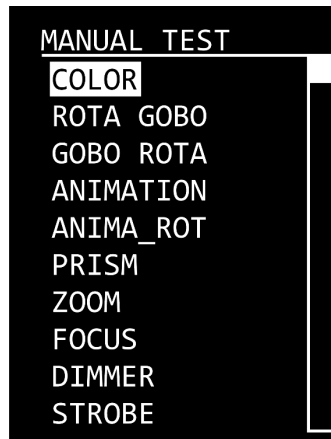

- **COLOR:** Set the position of the color wheel. The adjustment range is 0–255
- **ROTA GOBO:** Set the position of the gobo wheel. The adjustment range is 0–255
- **GOBO ROTA:** Set the rotation speed of the gobo wheel. The adjustment range is 0–255
- **ANIMATION:** Set the position of the effect wheel. The adjustment range is 0–255
- **ANIMA_ROT** Set the rotation speed of the effect wheel. The adjustment range is 0–255
- **PRISM** Set the rotation speed of the prism. The adjustment range is 0–255
- **ZOOM:** Set the zoom adjustment. The adjustment range is 0–255
- **FOCUS:** Set the focus adjustment. The adjustment range is 0–255
- **DIMMER:** Set the intensity of the dimmer. The adjustment range is 0–255, from low to high intensity
- **STROBE:** Add strobe effect. The adjustment range is 0–25, from OFF to high frequency

02) Press the **ENTER** button to confirm.

03) Press the **UP/DOWN** buttons to increase/decrease the values.

04) Press the **ENTER** button to set the value.

6.6.6.2. Reset

In this submenu you can manually reset the parameters of the device.

01) Press the **UP/DOWN** buttons to select one of the following 4 options:



- **ALL RESET:** Reset all parameters
- **COLOR SYS:** Color wheel, gobo wheel, rotating gobo reset
- **ZOOM SYS:** Zoom, focus reset
- **OTHER:** Prism, effect wheel reset

02) Press the **ENTER** button to confirm and perform the reset.

6.6.7. Info

In this menu you can view the parameters of the device.

01) Press the **UP/DOWN** buttons to select one of the following 5 options:



- **FIXTURE HOURS:** Shows the total hours of operation of the device
- **TEMPERATURE:** Provides information about the temperature of the LEDs
- **VERSION:** Provides information about the firmware version of the following parameters: DISPLAY and MOTO. Press the **UP/DOWN** buttons to scroll through the 2 screens
- **RDM:** Shows the UID number and name (LABEL) of the device
- **SYSTEM ERROR:** See **6.7.7.1. System Error**

02) Press the **ENTER** button to confirm.

6.6.7.1. System Error

In this submenu you can view whether there are any system errors.

Press the **UP/DOWN** buttons to scroll through the following 10 options:

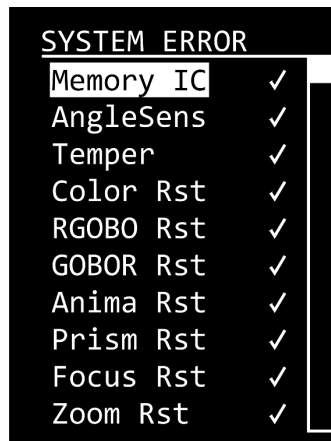

The displayed parameters are:

- MEMORY IC
- ANGLE SENSOR
- TEMPERATURE
- COLOR RESET
- RGOBO RESET
- GOBOR RESET
- ANIMATION RESET
- PRISM RESET
- FOCUS RESET
- ZOOM RESET

If there are no errors, the display shows √ (OK) next to the parameter. If there are errors, the display shows ERROR. Contact your Highlite International dealer if there is a system error.

6.6.8. Service

In this menu you can calibrate some of the parameters of the device. This menu requires a password. The default password is pressing the **UP/DOWN** buttons in the following order: **UP, DOWN, UP, DOWN**, then press **ENTER**

- 01) Enter the password.
- 02) Press the **ENTER** button to confirm the password and enter the submenu.
- 03) Press the **UP/DOWN** buttons to select one of the following 7 options:

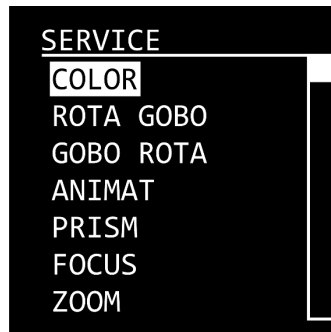

- **COLOR:** Adjust the home position of the color wheel. The adjustment range is between -127 and +127
- **ROTA GOBO:** Adjust of the home position of the rotating gobo wheel. The adjustment range is between -127 and +127
- **GOBO ROTA:** Adjust of the home position of the rotation position of the gobo wheel. The adjustment range is between -127 and +127
- **ANIMAT:** Adjust of the home position of the effect wheel. The adjustment range is between -127 and +127
- **PRISM:** Adjust of the home position of the effect wheel. The adjustment range is between -127 and +127
- **FOCUS:** Adjust of the home position of the effect wheel. The adjustment range is between -127 and +127
- **ZOOM:** Adjust of the home position of the effect wheel. The adjustment range is between -127 and +127

- 04) Press the **ENTER** button to confirm.
- 05) Press the **UP/DOWN** buttons to increase/decrease the value or make a selection.
- 06) Press the **ENTER** button to set the value or confirm.

6.7. DMX Channels

6.7.1. 11, 14 Channels

11 CH	14 CH	Function	Value	Setting
1	1	Master Dimmer	000–255	From low to high intensity (0–100 %)
	2	Dimmer Fine	000–255	From low to high intensity (0–100 %)
2	3	Strobe	000–009	No function
			010–099	Linear strobe, from low to high frequency (0–25 Hz)
			100–109	Shutter open
			110–179	Pulse strobe, from slow to fast
			180–189	Shutter open
			190–255	Random strobe slow to fast
3	4	Color wheel	000–007	White
			008–015	Red
			016–023	Light blue
			024–031	Green
			032–039	Pink
			040–047	Yellow
			048–191	Color wheel indexing
			192–222	Clockwise rotation, from fast to slow
			223–224	Stop
			225–255	Counter-clockwise rotation, from slow to fast
	5	Color Wheel Fine	000–255	Color wheel positioning fine-tuning
4	6	Gobo wheel	000–010	Open
			011–024	Gobo 1
			025–038	Gobo 2
			039–052	Gobo 3
			053–066	Gobo 4
			067–080	Rotating Gobo 1 shake effect, from slow to fast
			081–094	Rotating Gobo 2 shake effect, from slow to fast
			095–108	Rotating Gobo 3 shake effect, from slow to fast
			109–122	Rotating Gobo 4 shake effect, from slow to fast
			123–127	Open
			128–190	Clockwise rotation (CW) gobo flow from fast to slow
			191–192	Stop
			193–255	Counter-clockwise rotation (CCW) gobo flow from slow to fast
5	7	Gobo rotation	000–121	Gobo Indexing
			122–125	Stop
			126–165	Rotating gobo shake effect, from slow to fast
			166–170	Stop
			171–210	Clockwise gobo rotation, from fast to slow
			211–215	Stop
216–255	Counter-clockwise gobo rotation, from slow to fast			
6	8	Effect wheel	000–255	Effect wheel location
7	9	Effect wheel rotation	000–010	No rotation
			011–131	Clockwise effect wheel rotation, from fast to slow
			132–134	Stop
135–255	Counter-clockwise effect wheel rotation, from slow to fast			
8	10	Prism (4-facet)	000–010	Open
			011–155	Prism indexing
			156–157	Stop
			158–205	Clockwise prism rotation, from fast to slow
			206–207	Stop
208–255	Counter-clockwise prism rotation, from slow to fast			

11 CH	14 CH	Function	Value	Setting
9	11	Zoom	000–255	Zoom adjustment
10	12	Focus	000–255	Gradual focus adjustment, 0–100 %
	13	Focus Fine	000–255	Gradual focus adjustment, 0–100 %
11	14	Function	000–010	No function
			011–060	Reserved
			061–070	Live (Auto)
			071–080	Studio (Slow)
			081–090	Power (Fast)
			091–100	Reserved
			101–110	Dimmer off
			111–120	Dimmer DIM4
			121–150	Reserved
			151–160	1200Hz
			161–170	2400Hz
			171–180	4000Hz
			181–190	6000Hz
			191–200	25000Hz
			201–210	All reset
			211–220	Color wheel, gobo wheel, rotating gobo reset
			221–230	Zoom, focus reset
			231–240	Prism, dynamic effect wheel reset
			241–255	Reserved

6.8. Rotating Gobo Wheel, Effect Wheel and Color Wheel

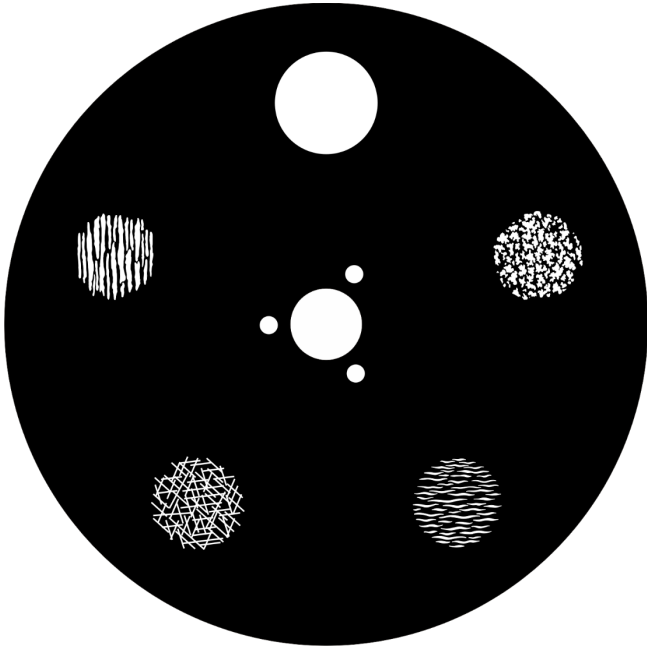

Fig. 12

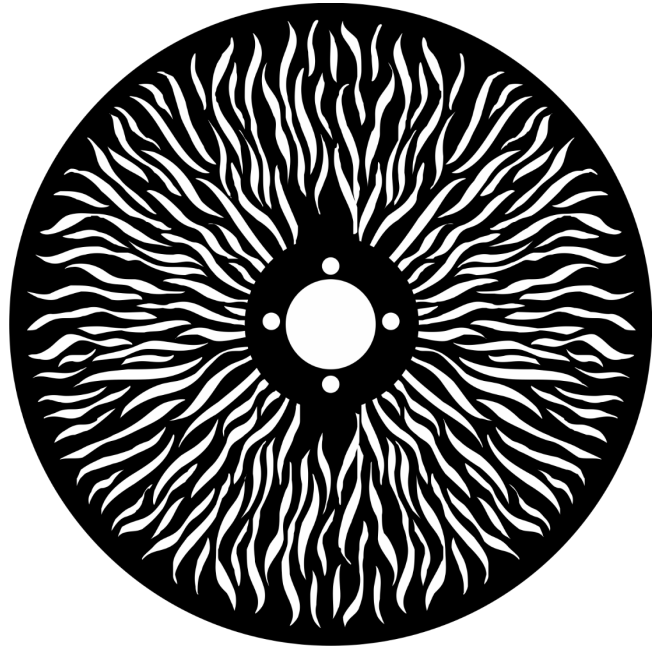

Fig. 13

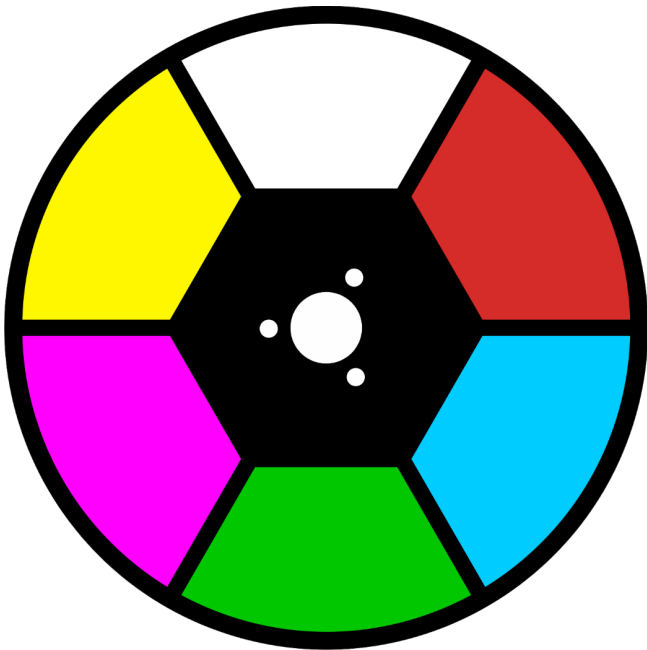

Fig. 14

6.8.1. Replacing a Gobo from the Rotating Gobo Wheel



DANGER
Electric shock caused by dangerous voltage inside

There are areas within the device where dangerous touch voltage may be present.

- Disconnect the device from electrical power supply before service and maintenance, and when the device is not in use.
- Allow the device to cool down before opening the cover.
- Use for replacement only gobos that match the specifications below. Using custom gobos that do not match those specifications may result in damage to the device. Any damage to the device as a result of using a custom gobo is not covered under warranty.
- Do not touch the glass gobo with bare fingers to avoid leaving fingerprints. Handle the gobo only by the gobo carrier, or wear protective gloves. If you touch the glass, clean with a soft lint-free cloth and rubbing alcohol.

To replace a rotating gobo, follow the steps below:

- 01) Disconnect the device from the mains and allow it to cool completely.
- 02) Set the device in horizontal position with the lens facing forward.
- 03) Loosen the 6 hex screws on the maintenance cover, as shown in Fig. 15.

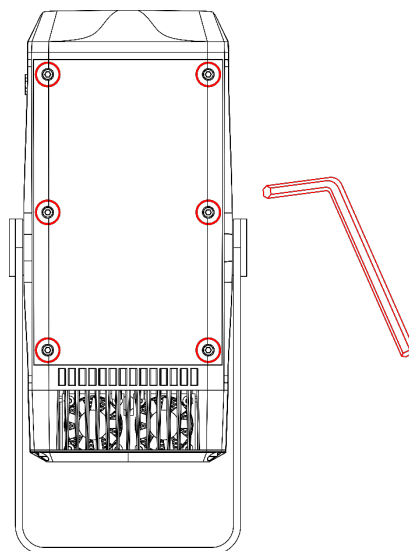

Fig. 15

- 04) Carefully remove the head cover from the housing to get access to the rotating gobo wheel.
- 05) Turn the rotating gobo wheel by hand until you reach the gobo which you want to replace.
- 06) Gently lift the gobo holder a bit up and pull it out from the rotating gobo wheel, as shown in Fig. 16 and Fig. 17.

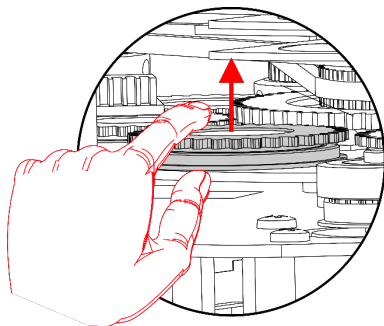

Fig. 16

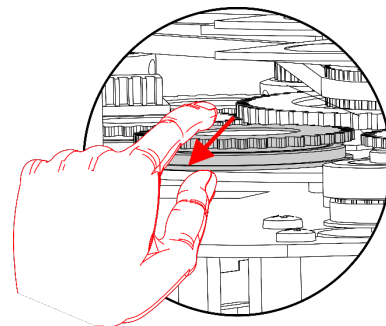

Fig. 17

- 07) Very carefully take the gobo out of the gobo holder with a pair of pliers.
- 08) Take the gobo out of the gobo holder. Do not touch the gobo with bare fingers.
- 09) Put the new gobo in the gobo holder.
- 10) Carefully put the pinchcock back. You can use a pair of pliers to press the pinchcock a little bit together. See **6.8.3. Glass Gobo Orientation** on page 37 for more information.
- 11) Put the gobo holder back under the pressing snap and push it back into position.
- 12) Replace the maintenance cover and fasten all 6 hex screws.

6.8.2. Gobo Size

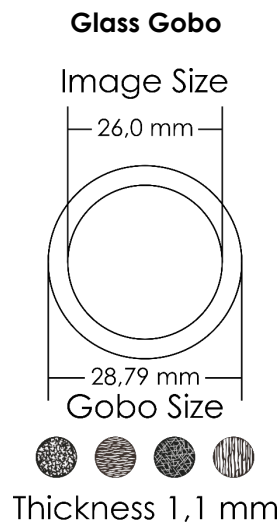

Fig. 18

6.8.3. Glass Gobo Orientation

Coated glass gobos are inserted with the coating against the rim of the holder. Textured gobos are inserted with the smooth side pointing away from the holder. This provides the best results when combining rotating gobos.

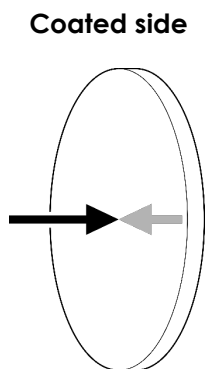

Fig. 19

When an object is held up to the coated side, there is no space between the object and its reflection. The back edge of the gobo cannot be seen when looking through the coated side.

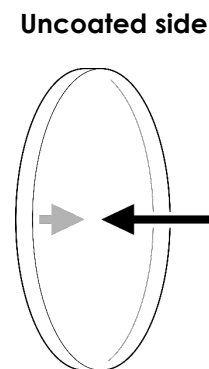

Fig. 20

When an object is held up to the uncoated side, there is a space between the object and its reflection. The back edge of the gobo can be seen when looking through the uncoated side.

6.9. RDM Information

This device supports RDM. Refer to **6.8.2. Supported RDM PIDs (Parameter IDs)** for more information.

6.9.1. RDM Details

- Responder: 29B4:0CDxxxxx
- Manufacturer's ID: Showtec (Highlite International B.V.)
- Manufacturer Label: Arctea
- Model Description: Image Spot 150 CW
- Model ID: 205
- Device Label: Image Spot 150 CW

6.9.2. Supported RDM PIDs (Parameter IDs)

Parameter ID	Value	Required	GET	SET
COMMS_STATUS	0x0015		*	*
STATUS_MESSAGES	0x0030		*	
STATUS_ID_DESCRIPTION	0x0031		*	
CLEAR_STATUS_ID	0x0032			*
SUPPORTED_PARAMETERS	0x0050	*	*	
DEVICE_MODEL_DESCRIPTION	0x0080		*	
MANUFACTURER_LABEL	0x0081		*	
DEVICE_LABEL	0x0082		*	*
LANGUAGE_CAPABILITIES	0x00A0		*	
LANGUAGE	0x00B0		*	*
DMX_PERSONALITY	0x00E0		*	*
DMX_PERSONALITY_DESCRIPTION	0x00E1		*	
DMX_START_ADDRESS	0x00F0	*	*	*
SENSOR_DEFINITION	0x0200		*	
SENSOR_VALUE	0x0201		*	*
RECORD_SENSORS	0x0202			*
CURVE	0x0343		*	*
CURVE_DESCRIPTION	0x0344	*	*	
MODULATION_FREQUENCY	0x0347		*	*
MODULATION_FREQUENCY_DESCRIPTION	0x0348	*	*	

6.9.3. Highlite RDM Details

All Highlite RDM responder IDs are divided into 3 parts, starting with a 4-digit Manufacturer's ID, followed by a 3-digit Model ID, and a 5-digit unique ID for each item.

As a result, RDM responder IDs will always start with the same 7 digits (exclusive to each type of device). The last 5 digits will be different for each device.

7. Troubleshooting

This troubleshooting guide contains solutions to problems which can be carried out by an ordinary person. The device does not contain user-serviceable parts.

Unauthorized modifications to the device will render the warranty void. Such modifications may result in injuries and material damage.

Refer servicing to instructed or skilled persons. Contact your Highlite International dealer in case the solution is not described in the table.

Problem	Probable cause(s)	Solution
The device does not function at all	No power to the device	<ul style="list-style-type: none"> • Make sure the power is switched on and cables are plugged in
	Main fuse is blown	<ul style="list-style-type: none"> • Disconnect the device and contact your Highlite International dealer
The device does not respond to DMX control	The controller is not connected	<ul style="list-style-type: none"> • Connect the controller
	The signal is reversed. The 3-pin/5-pin DMX OUT of the controller does not match the DMX IN of the device	<ul style="list-style-type: none"> • Install a phase-reversing cable between the controller and the device
	The controller is defective	<ul style="list-style-type: none"> • Try using another controller
The device responds erratically to DMX control	Bad data link connection	<ul style="list-style-type: none"> • Examine connections and cables. Correct poor connections. Repair or replace damaged cables
	The data link is not terminated with a 120 Ω termination plug	<ul style="list-style-type: none"> • Insert a termination plug in the DMX OUT connector of the last device on the link
	Incorrect addressing	<ul style="list-style-type: none"> • Check address settings and correct, if necessary
	In case of a setup with multiple devices, one of the devices is defective and disturbs data transmission on the link	<ul style="list-style-type: none"> • To find out the defective device, bypass one device at a time until normal operation is restored
No light or LEDs cut out intermittently	LEDs are damaged	<ul style="list-style-type: none"> • Disconnect the device and contact your Highlite International dealer
	The power supply settings do not match local AC voltage and frequency	<ul style="list-style-type: none"> • Disconnect the device. Check the settings and correct, if necessary

8. Maintenance

8.1. Safety Instructions for Maintenance



DANGER
Electric shock caused by dangerous voltage inside

Disconnect power supply before servicing or cleaning.

8.2. Preventive Maintenance



Attention
Before each use, examine the device visually for any defects.

Make sure that:

- All screws used for installing the device or parts of the device are tightly fastened and are not corroded.
- The safety devices are not damaged.
- There are no deformations on housings, fixations and installation points.
- The lens is not cracked or damaged.
- The power cables are not damaged and do not show any material fatigue.

8.2.1. Basic Cleaning Instructions

The external lens of the device must be cleaned periodically in order to optimize the light output. The cleaning schedule depends on the conditions at the site where the device is installed. When smoke or fog machines are used at the site, the device will need more frequent cleaning. On the other hand, if the device is installed in well-ventilated area, it will need less frequent cleaning. To establish a cleaning schedule, examine the device at regular intervals during the first 100 hours of operation.

To clean the device, follow the steps below:

- 01) Disconnect the device from the electrical power supply.
- 02) Allow the device to cool down for at least 15 minutes.
- 03) Remove the dust collected on the external surface with dry compressed air and a soft brush.
- 04) Clean the lens with a damp cloth. Use a mild detergent solution.
- 05) Dry the lens carefully with a lint-free cloth.
- 06) Clean the DMX and other connections with a damp cloth.



Attention

- Do not immerse the device in liquid.
- Do not use alcohol or solvents.
- Make sure that the connections are fully dry before connecting the device to the power supply and to other devices.

8.2.2. Draining Condensation Water

The Image Spot 150 CW is IP66 rated. The device can resist water jets. If the device is exposed to extreme humid conditions during servicing, condensation may collect inside the device. This can happen also during transportation, if the device is exposed to extreme temperature variations.

If condensation water collects inside the device, follow the steps below to remove the condensation water:

01) Carefully remove the **protective vent (02)** with a wrench (16 mm).

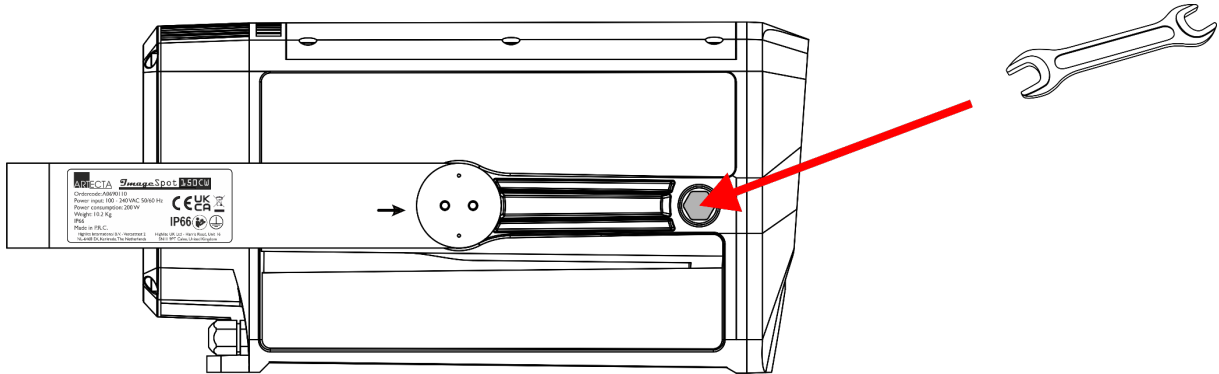

Fig. 21

02) Let the device operate at full output for 60 minutes.

03) Let the device cool down for 30 minutes.

04) Install the **protective vent (02)** back in place. Make sure that you do not overtighten it.

8.3. Corrective Maintenance

The device does not contain user-serviceable parts. Do not open the device and do not modify the device.

Refer repairs and servicing to instructed or skilled persons. Contact your Highlite International dealer for more information.

9. Deinstallation, Transportation and Storage

9.1. Instructions for Deinstallation



WARNING
Incorrect deinstallation can cause serious injuries and damage of property.

- Let the device cool down before dismounting.
- Disconnect power supply before deinstallation.
- Always observe the national and site-specific regulations during deinstallation and derigging of the device.
- Wear personal protective equipment in compliance with the national and site-specific regulations.

9.2. Instructions for Transportation

- Use the original packaging to transport the device, if possible.
- Always observe the handling instructions printed on the outer carton box, for example: "Handle with care", "This side up", "Fragile".

9.3. Storage

- Clean the device before storing. Follow the cleaning instructions in chapter **8.2.1. Basic Cleaning Instructions** on page 40.
- Store the device in the original packaging, if possible.

10. Disposal

Correct disposal of this product

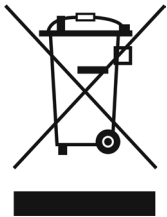

Waste Electrical and Electronic Equipment

This symbol on the product, its packaging or documents indicates that the product shall not be treated as household waste. Dispose of this product by handing it to the respective collection point for recycling of electrical and electronic equipment. This is to avoid environmental damage or personal injury due to uncontrolled waste disposal. For more detailed information about recycling of this product contact the local authorities or the authorized dealer.

11. Approval



Check the respective product page on the website of Highlite International (www.highlite.com) for an available declaration of conformity.



©2023 Artecta