

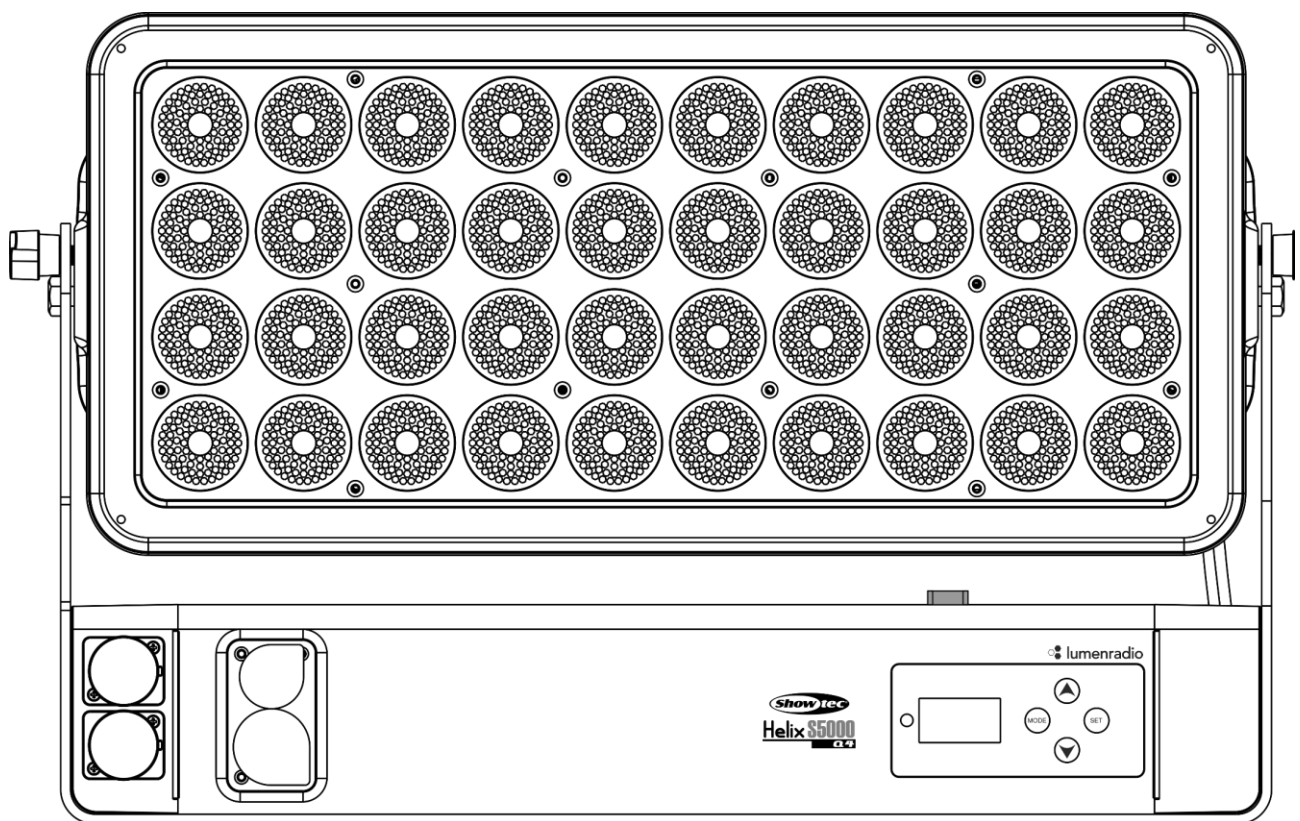

USER MANUAL



ENGLISH

Helix S5000 10° IP65

V1

Product code: 43724

Firmware version: 2.6

Preface

Thank you for purchasing this Showtec product.

The purpose of this user manual is to provide instructions for the correct and safe use of this product.

Keep the user manual for future reference as it is an integral part of the product. The user manual shall be stored at an easily accessible location.

This user manual contains information concerning:

- Safety instructions
- Intended and non-intended use of the device
- Installation and operation of the device
- Maintenance procedures
- Troubleshooting
- Transport, storage and disposal of the device

Non-observance of the instructions in this user manual may result in serious injuries and damage of property.

©2023 Showtec. All rights reserved.

No part of this document may be copied, published or otherwise reproduced without the prior written consent of Highlite International.

Design and product specifications are subject to change without prior notice.

For the latest version of this document and other language versions, please visit our website www.highlite.com or contact us at service@highlite.com.

Highlite International and its authorized service providers are not liable for any injury, damage, direct or indirect loss, consequential or economic loss or any other loss arising from the use of, or inability to use or reliance on the information contained in this document.

Table of contents

1. Introduction	4
1.1. Before Using the Product	4
1.2. Intended Use	4
1.3. Product Lifespan	4
1.4. LEDs Lifespan	5
1.5. Text Conventions	5
1.6. Symbols and Signal Words	5
1.7. Symbols on the Information Label	5
2. Safety	6
2.1. Warnings and Safety Instructions	6
2.2. Requirements for the User	9
3. Description of the Device	10
3.1. Front View	10
3.2. Bottom View	10
3.3. Product Specifications	11
3.4. Dimensions	12
3.5. Optional Accessories	12
4. Installation	13
4.1. Safety Instructions for Installation	13
4.2. Personal Protective Equipment	13
4.3. Installation Site Requirements	13
4.4. Installing the Beamshapers (43727/43728/43729)	14
4.5. Installing the Barndoor (43726)	15
4.6. Installing the Tophat (43730)	17
4.7. Rigging	19
4.7.1. Angle Adjustment	20
4.8. Connecting to Power Supply	21
4.9. Power Linking of Multiple Devices	21
5. Setup	22
5.1. Warnings and Precautions	22
5.2. Stand-alone Setup	22
5.3. DMX Connection	22
5.3.1. DMX-512 Protocol	22
5.3.2. DMX Cables	23
5.3.3. Master/Slave Setup	23
5.3.4. DMX Linking	24
5.3.5. DMX Addressing	24
5.3.6. Multiple Helixes (Wireless DMX Control)	25
5.3.6.1. LumenRadio 2.4GHz Wireless Communication Module	25
5.3.6.2. Wireless DMX Connection	25
5.3.6.3. Wireless DMX Problems	25
5.3.6.4. Connect the Helix to the Wireless DMX Signal Transmitter	26
5.3.6.5. Disconnect the Helix from the Wireless DMX Signal Transmitter	26
5.3.6.6. Setup Example 1	26
5.3.6.7. Setup Example 2	27
6. Operation	28
6.1. Safety Instructions for Operation	28
6.2. Control Modes	28
6.3. Control Panel	29
6.4. Start-up	29
6.5. Menu Overview	30
6.6. Main Menu Options	32
6.6.1. DMX Settings	32

6.6.1.1.	DMX Address	32
6.6.1.2.	DMX Channels	33
6.6.1.3.	DMX Signal.....	33
6.6.1.4.	CRMX Unlock.....	33
6.6.2.	Manual Mode	34
6.6.3.	Auto Mode	34
6.6.4.	Built-in Programs Mode	35
6.6.4.1.	Program 01 / Static Colors	35
6.6.4.2.	Program 02–26	35
6.6.5.	Slave Mode	36
6.6.6.	Settings.....	36
6.6.6.1.	Curves Select	37
6.6.6.2.	Dimmer Speed	38
6.6.6.3.	Fan Speed	38
6.6.6.4.	Pixel Dir	38
6.6.6.5.	PWM Frequency	38
6.6.6.6.	PWM Frequency	39
6.6.6.7.	DMX Fail	39
6.6.6.8.	DMX Sync.....	39
6.6.6.9.	Lock.....	40
6.6.6.10.	Key Backlight.....	40
6.6.6.11.	Strobe Mode	40
6.6.6.12.	Factory Reset	41
6.6.7.	Information	41
6.7.	DMX Channels.....	42
6.7.1.	4 channels, 6 channels	42
6.7.2.	8 channels	42
6.7.3.	20 channels, 24 channels	44
6.8.	RDM Information	47
6.8.1.	RDM Details	47
6.8.2.	Supported RDM PIDs (Parameter IDs)	47
6.8.3.	Highlite RDM Details	47
7.	Troubleshooting	48
8.	Maintenance	49
8.1.	Safety Instructions for Maintenance	49
8.2.	Preventive Maintenance	49
8.2.1.	Basic Cleaning Instructions.....	49
8.2.2.	Draining Condensation Water	50
8.3.	Corrective Maintenance	50
9.	Deinstallation, Transportation and Storage	51
9.1.	Instructions for Deinstallation	51
9.2.	Instructions for Transportation	51
9.3.	Storage	51
10.	Disposal	51
11.	Approval.....	51

1. Introduction

1.1. Before Using the Product



Important
Read and follow the instructions in this user manual before installing, operating or servicing this product.

The manufacturer will not accept liability for any resulting damages caused by the non-observance of this manual.

After unpacking, check the contents of the box. If any parts are missing or damaged, contact your Highlite International dealer.

Your shipment includes:

- Showtec Helix S5000 10° IP65
- Schuko to Neutrik PowerCON True1 power cable (1,5 m)
- 6 x quick-lock
- 2 x quick-lock bracket
- 4 x rubber foot
- 1 x mounting bracket
- User manual

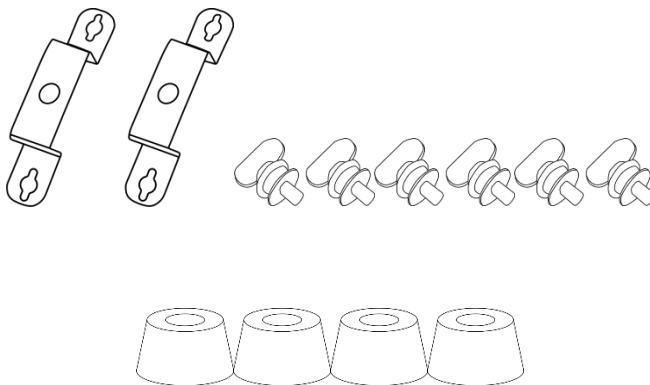
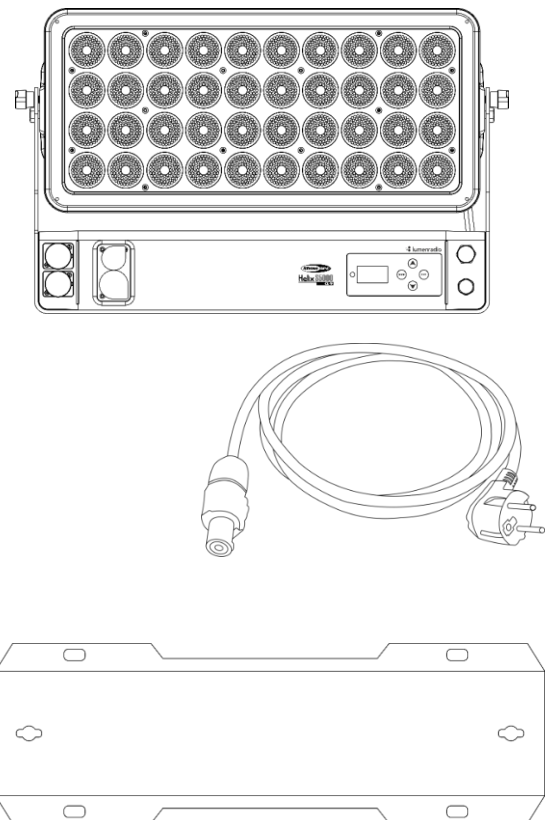

Fig. 01

1.2. Intended Use

This device is intended for professional use as an outdoor spot. It is not suitable for households and for general lighting.

Any other use, not mentioned under intended use, is regarded as non-intended and incorrect use.

1.3. Product Lifespan

This device is not designed for permanent operation. Disconnect the device from the electrical power supply when the device is not in operation. This will reduce the wear and will improve the device's lifespan.

1.4. LEDs Lifespan

The light output of the LEDs gradually decreases over time (lumen depreciation). High operating temperatures contribute to this process. You can extend the lifespan of the LEDs by providing adequate ventilation and operating the LEDs at the lowest possible brightness.

1.5. Text Conventions

Throughout the user manual the following text conventions are used:

- Buttons: All buttons are in bold lettering, for example "Press the **UP/DOWN** buttons"
- References: References to chapters and parts of the device are in bold lettering, for example: "Refer to **2. Safety**", "turn the **adjustment handle (05)**"
- 0–255: Defines a range of values
- Notes: **Note:** (in bold lettering) is followed by useful information or tips

1.6. Symbols and Signal Words

Safety notes and warnings are indicated throughout the user manual by safety signs.

Always follow the instructions provided in this user manual.



DANGER

Indicates an imminently hazardous situation which, if not avoided, will result in death or serious injury.



WARNING

Indicates a potentially hazardous situation which, if not avoided, could result in death or serious injury.



CAUTION

Indicates a potentially hazardous situation, which, if not avoided, may result in minor or moderate injury.



Attention

Indicates important information for the correct operation and use of the product.



Important

Read and observe the instructions in this document.



Electrical hazard



Eye damage hazard



Provides important information about the disposal of this product.



1.7. Symbols on the Information Label

This product is provided with an information label. The information label is located on the mounting bracket of the device.

The information label contains the following symbols:



This device shall not be treated as household waste.



This device falls under IEC protection class I.

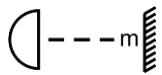

Minimum distance from lighted objects.

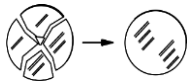

Replace any cracked protective shield.



Caution: Risk of electric shock. Do not open.

Caution: To reduce the risk of electrical shock, do not remove cover. No user-serviceable parts inside. Refer servicing to qualified personnel.

2. Safety



Important

Read and follow the instructions in this user manual before installing, operating or servicing this product.

The manufacturer will not accept liability for any resulting damages caused by the non-observance of this manual.

2.1. Warnings and Safety Instructions



DANGER

Danger for children

For adult use only. The device must be installed beyond the reach of children.

- Do not leave various parts of the packaging (plastic bags, polystyrene foam, nails, etc.) within children's reach. Packaging material is a potential source of danger for children.



DANGER

Electric shock caused by dangerous voltage inside

There are areas within the device where dangerous touch voltage may be present.

- Do not open the device or remove any covers.
- Do not operate the device if the covers or the housing are open. Before operation, check if the housing is firmly closed and all screws are tightly fastened.
- Disconnect the device from electrical power supply before service and maintenance, and when the device is not in use.



DANGER

Electric shock caused by short-circuit

This device falls under IEC protection class I.

- Make sure that the device is electrically connected to ground (earth). Connect the device only to a socket-outlet with ground (earth) connection.
- Do not cover the ground (earth) connection.
- Do not bypass the thermostatic switch or fuses.

- Do not let the power cable come into contact with other cables. Handle the power cable and all connections with the mains with caution.
- Do not modify, bend, mechanically strain, put pressure on, pull or heat up the power cable.
- Make sure that the power cable is not crimped or damaged. Examine the power cable periodically for any defects.
- Do not immerse the device in water or other liquids. Do not install the device in a location where flooding may occur.
- Do not use the device during thunderstorms. Disconnect the device from the electrical power supply immediately.
- Keep the connectors sealed with the rubber caps when the connectors are not in use.
- Do not connect the cables from above the connectors, if the device is installed outdoors. Make a 'drip loop' in the cable so that rain water cannot enter the device.



WARNING
Risk of epileptic shock

Strobe lighting can trigger seizures in photosensitive epilepsy. Sensitive persons should avoid looking at strobe lights.



CAUTION
Possible eye damage caused by high light intensity

Possibly hazardous optical radiation emitted from this device.

- Do not look at the operating light source. May be harmful to the eye.
- Do not look at the light source with optical instruments that may concentrate the light output.
- Make sure that persons are not looking directly into the light source when the device lights up suddenly. This can happen when the device is powered or when it receives DMX signal, or when certain menu items are selected.
- Disconnect power supply before servicing.
- Wear protective goggles if looking into light source during service or maintenance.



Attention
Power supply

- Before connecting the device to the power supply, make sure that the current, voltage and frequency match the input voltage, current and frequency specified on the information label on the device.
- Make sure that the cross-sectional area of the extension cords and power cables is sufficient for the required power consumption of the device.



Attention
General safety

- Do not connect the device to a dimmer pack.
- Do not switch the device on and off in short intervals. This decreases the device's life.
- Do not shake the device. Avoid brute force when installing or operating the device.
- Change the lens or the LEDs if they are visibly damaged to such an extent that their effectiveness is impaired, for example by cracks or deep scratches. Contact your Highlite International dealer for more information, as servicing can be performed only by instructed or skilled persons.

- If the device is dropped or struck, disconnect the device from the electrical power supply immediately.
- If the device is exposed to extreme temperature variations (e.g. after transportation), do not switch it on immediately. Let the device reach room temperature before switching it on, otherwise it may be damaged by the formed condensation.
- If the device fails to work properly, discontinue the use immediately.



Attention
For professional use only
This device shall be used only for the purposes it is designed for.

This device is designed to be used as a professional outdoor spot. Any incorrect use may lead to hazardous situations and result in injuries and material damage.

- This device is not suitable for households and for general lighting.
- This device is not designed for permanent operation.
- This device does not contain user-serviceable parts. Unauthorized modifications to the device will render the warranty void. Such modifications may result in injuries and material damage.



Attention
Before each use, examine the device visually for any defects.

Make sure that:

- All screws used for installing the device or parts of the device are tightly fastened and are not corroded.
- The safety devices are not damaged.
- There are no deformations on housings, fixations and installation points.
- The lens is not cracked or damaged.
- The power cables are not damaged and do not show any material fatigue.



Attention
Do not expose the device to conditions that exceed the rated IP class conditions.

This device is IP65 rated. IP (Ingress Protection) 65 class means that the device is dust-tight and protected against harmful effect of water jets.

Keep the connectors sealed with the rubber caps when the connectors are not in use.

2.2. Requirements for the User

This product may be used by ordinary persons. Maintenance may be carried by ordinary persons. Installation and service shall be carried out only by instructed or skilled persons. Contact your Highlite International dealer for more information.

Instructed persons have been instructed and trained by a skilled person, or are supervised by a skilled person, for specific tasks and work activities associated with the installation, service and maintenance of this product, so that they can identify risks and take precautions to avoid them.

Skilled persons have training or experience, which enables them to recognize risks and to avoid hazards associated with the installation, service and maintenance of this product.

Ordinary persons are all persons other than instructed persons and skilled persons. Ordinary persons include not only users of the product but also any other persons that may have access to the device or who may be in the vicinity of the device.

3. Description of the Device

The Showtec Helix S5000 is a 40x 10 W RGBW LED washer with IP65 rating, The device can be controlled via CRMX (wireless), DMX and Master/Slave in Manual and Auto-run mode with many built-in programs.

3.1. Front View

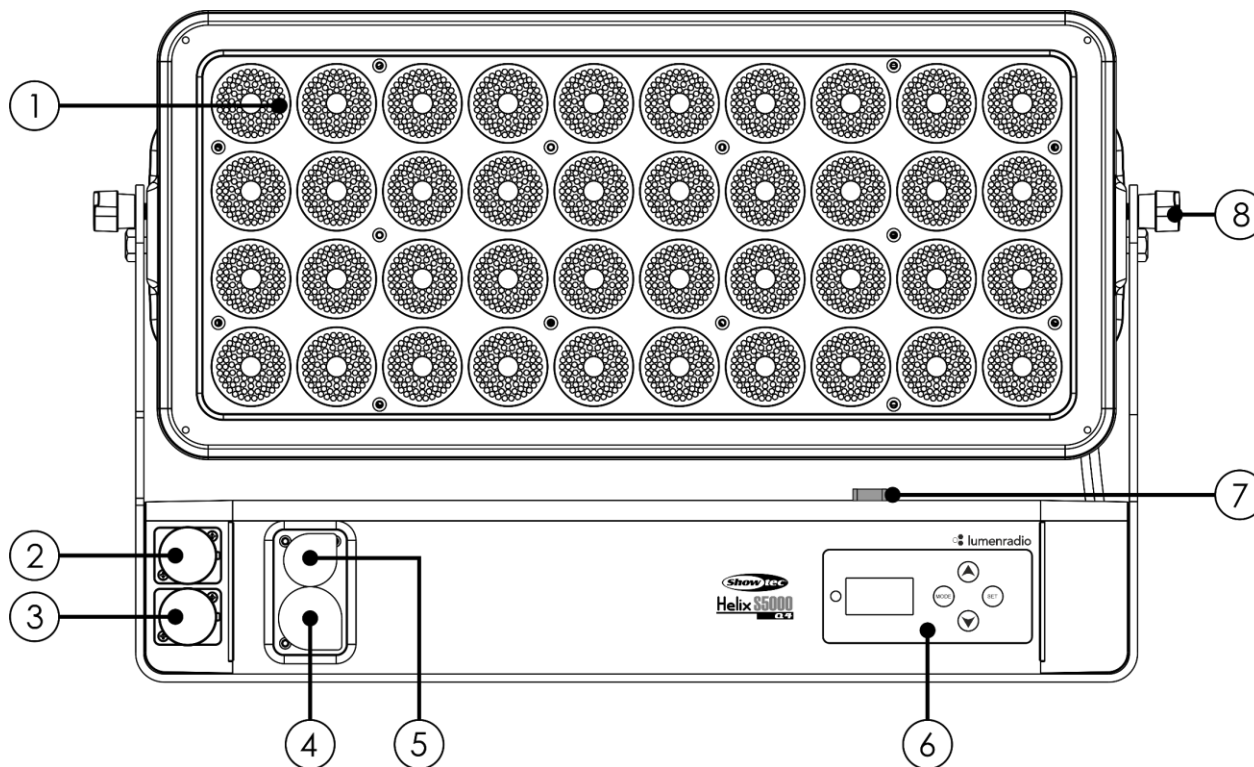
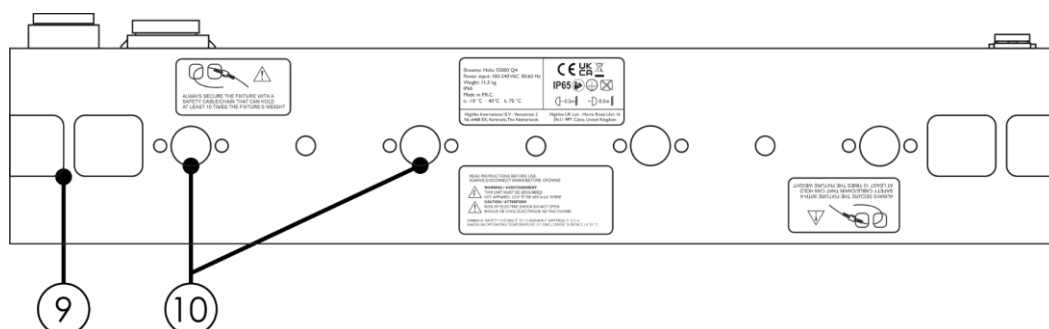

Fig. 02

- 01) 40 x Prolight Opto RGBW 4-in-1 10 W LEDs
- 02) 5-pin XLR-HD connector IN
- 03) 5-pin XLR-HD connector OUT
- 04) 100–240V Neutrik PowerCON True1 TOP power connector OUT
- 05) 100–240V Neutrik PowerCON True1 TOP power connector IN
- 06) OLED display + control buttons
- 07) Protective vent
- 08) 2 x Adjustment screw

3.2. Bottom View



- 09) 2 x Safety eye
- 10) 2 x Quick-lock

Fig. 03

3.3. Product Specifications

Model:	Helix S5000 10° IP65	
Electrical:		
Input voltage:	100–240 V AC, 50/60 Hz	
Power consumption:	415 W	
Physical:		
Dimensions:	530 x 125 x 330 mm (L x W x H)	
Weight:	11,5 kg	
Optics:		
Light source:	40 x Prolight Opto RGBW 4-in-1 10 W LEDs	
Dimmer:	0–100 %	
Beam angle horizontal:	10°	
Beam angle vertical:	10°	
Strobe:	0–20 Hz	
Lumen total:	14560 lm	
Lux @ 2m:	54000 lx	
Refresh rate:	3000 Hz	
Operation and control:		
Control:	Stand-alone (Auto, Built-in Programs, Manual) Master/Slave DMX-512, RDM Wireless DMX / CRMX	
DMX channels:	4, 6, 8, 20, 24 channels	
Control panel:	OLED display and buttons	
Wireless mode:	G3 / G4 / CRMX	
Wireless:	LumenRadio	
Carrier frequency:	2,4 GHz	
Reaction time:	8 ms	
Dimmer curve:	Linear / Square / I-Square / S-Curve	
Connections:		
Power connections:	IP65-rated powerCON True1 TOP power connectors IN/OUT	
Data connections:	IP65-rated 5-pin XLR-HD connectors IN/OUT	
Signal pinouts:	Pin 1 (ground), pin 2 (-), pin 3 (+), pin 4 (N/C), pin 5 (N/C)	
Construction:		
Housing:	Die-cast aluminum	
Color:	Black	
IP rating:	IP65	
Cooling:	Convection / Axial Fan	
Mounting options:	Baseplate / Clamp / Quick-Lock	
Thermal:		
Maximum ambient temperature t_a :	40 °C	
Minimum ambient temperature:	-10 °C	
Minimum distance:		
Minimum distance from flammable surfaces:	0,8 m	
Minimum distance to lighted object:	0,8 m	

3.4. Dimensions

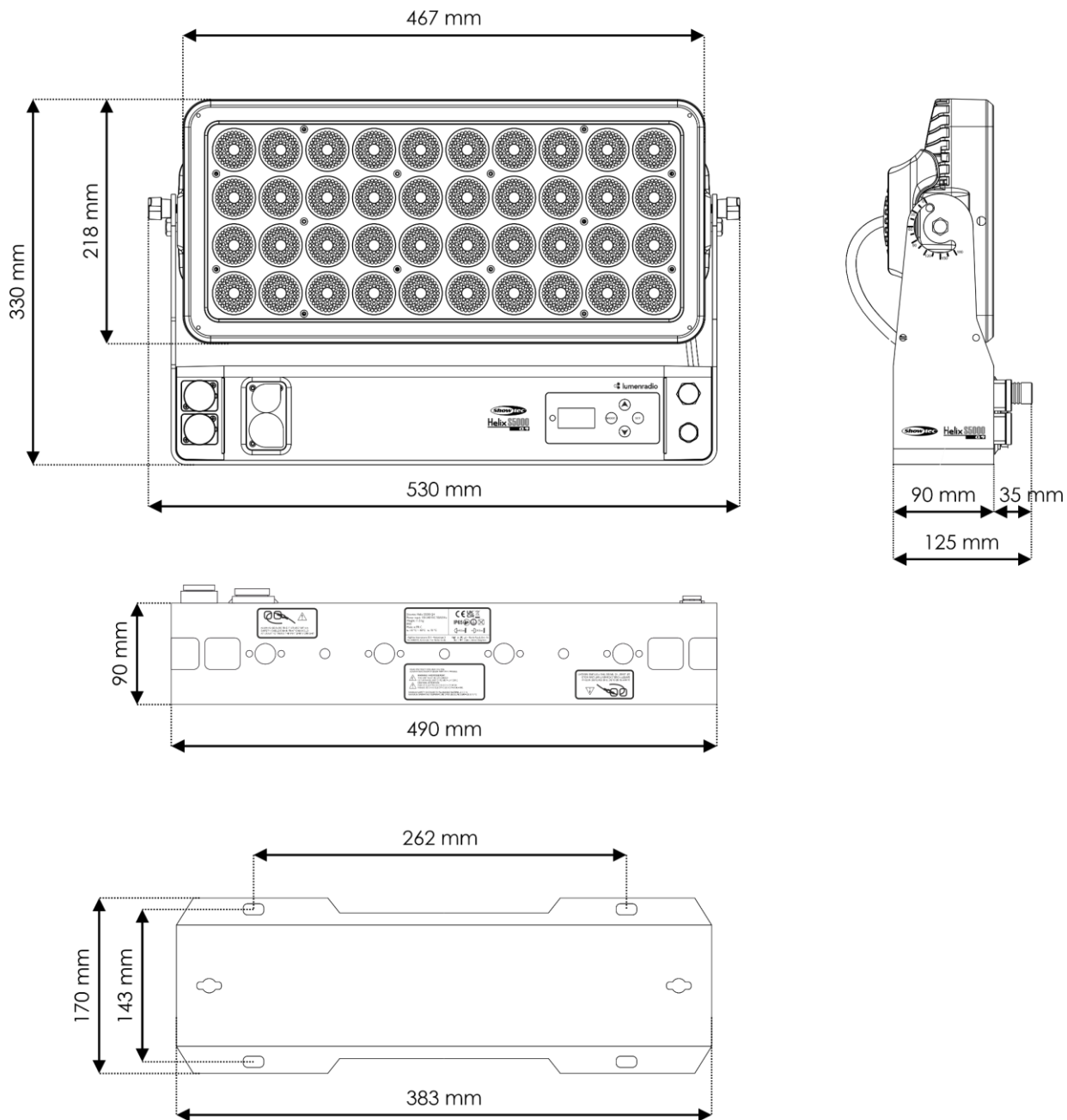

Fig. 04

3.5. Optional Accessories

The device is delivered without a barndoor, beamshaper or tophat. There are several accessories for this device:

- Product code: [43726](#) – Barndoor for Helix S5000 Q4
- Product code: [43727](#) – Beamshaper for Helix S5000 Q4 (20°)
- Product code: [43728](#) – Beamshaper for Helix S5000 Q4 (45°)
- Product code: [43729](#) – Beamshaper for Helix S5000 Q4 (15°x60°)
- Product code: [43730](#) – Tophat for Helix S5000 Q4
- Product code: [52001](#) – BlackBox F-1 G5 Transceiver
- Product code: [52002](#) – BlackBox F-2 G5 Transceiver
- Product code: [D7249](#) – Case for 4 x Helix 4000 / S5000

4. Installation

4.1. Safety Instructions for Installation



WARNING

Incorrect installation can cause serious injuries and damage of property.

If trussing systems are used, installation must be carried out only by instructed or skilled persons.

Follow all applicable European, national and local safety regulations concerning rigging and trussing.

4.2. Personal Protective Equipment

During installation and rigging wear personal protective equipment in compliance with the national and site-specific regulations.

4.3. Installation Site Requirements

- The device can be used outdoors.
- The device can be mounted to a truss or other rigging structure in any orientation.
- The minimum distance between the light output and the illuminated surface must be bigger than 0,8 m.
- The maximum ambient temperature $t_a = 40\text{ °C}$ must never be exceeded.

4.4. Installing the Beamshapers (43727/43728/43729)

You can attach a beamshaper to the device.

To install the beamshaper to the device:

- 01) Put the beamshaper on the lens of the device. The beamshaper is equipped with multiple magnets which keep it firmly in position. For extra safety, use a safety cable to connect the beamshaper to the device.
- 02) To remove the beamshaper, pull it by the handles located on its sides.

[43727](#) – Beamshaper for Helix S5000 Q4 (20°)

[43728](#) – Beamshaper for Helix S5000 Q4 (40°)

[43729](#) – Beamshaper for Helix S5000 Q4 (15°x60°)

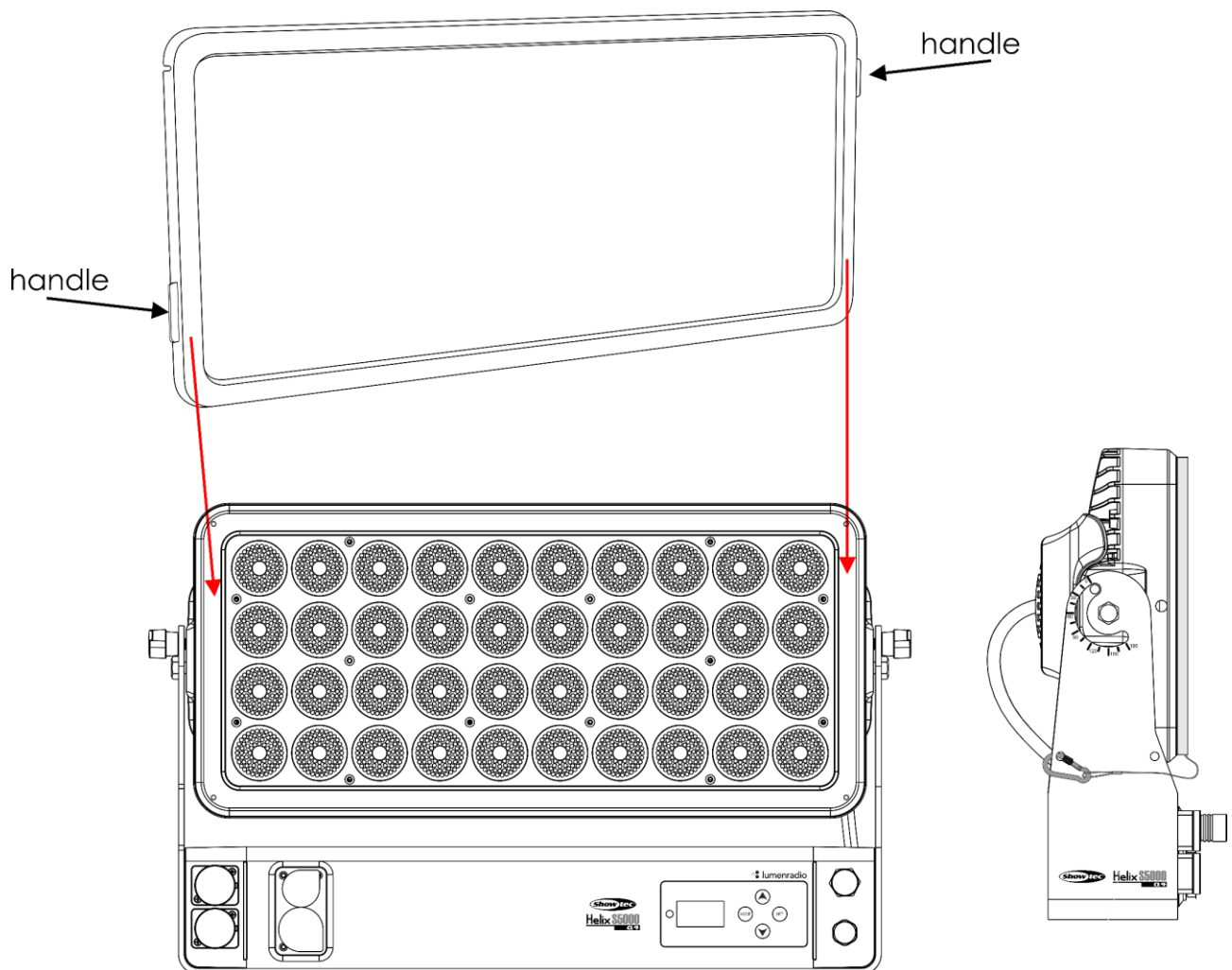

Fig. 05

4.5. Installing the Barndoor (43726)

You can attach a barndoor to the device.

To install the barndoor to the device:

- 01) Pull both spring-loaded locking pins on the barndoor, to unlock on the spring-loaded locking mechanism.

43726 - Barndoor for Helix S5000 Q4

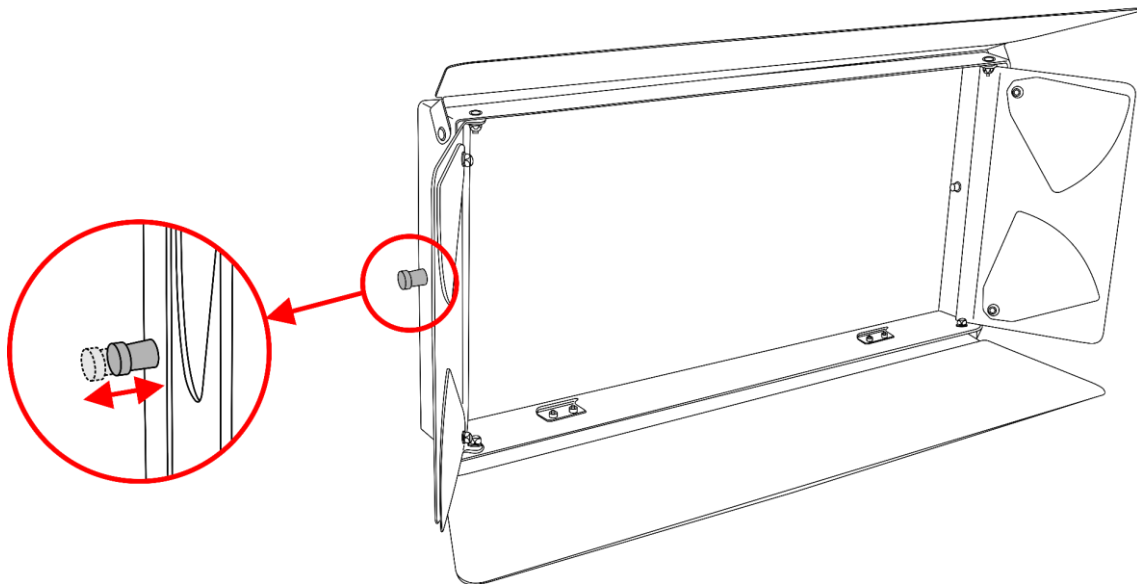
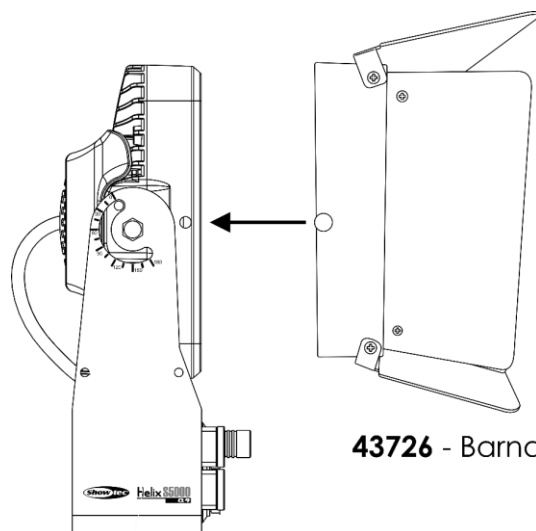

Fig. 06

- 02) Put the barndoor on the device, as shown in Fig. 07.

- 03) Make sure that the 2 pins are aligned with the openings of the spring-loaded locking mechanism.



43726 - Barndoor for Helix S5000 Q4

Fig. 07

- 04) Release both pins of the locking mechanism to lock the barndoor in position.
- 05) Make sure that the pins of the locking mechanism are firmly locked in the openings on the sides of the device. For extra safety, use a safety cable to connect the barndoor to the device.

Safety eye for a safety cable

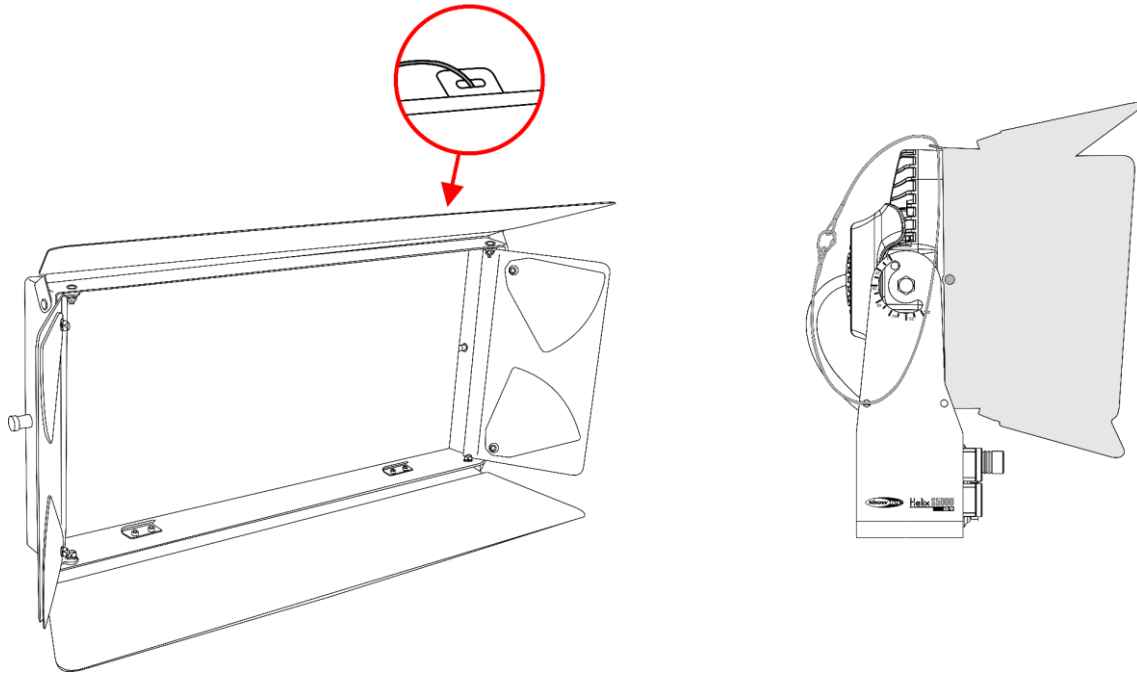

Fig. 08

4.6. Installing the Tophat (43730)

You can attach a tophat to the device.

To install the tophat to the device:

- 01) Pull both spring-loaded locking pins on the tophat, to unlock on the spring-loaded locking mechanism.

43730 - Tophat for Helix S5000 Q4

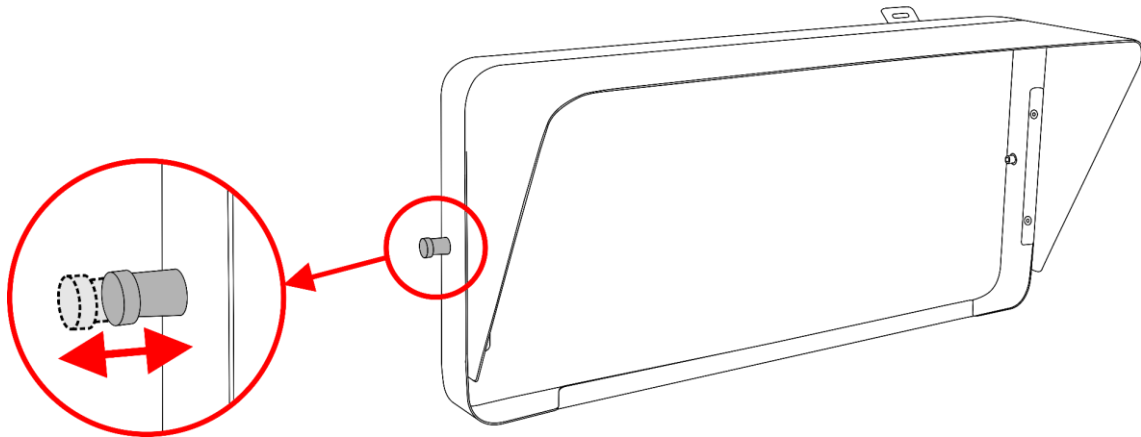
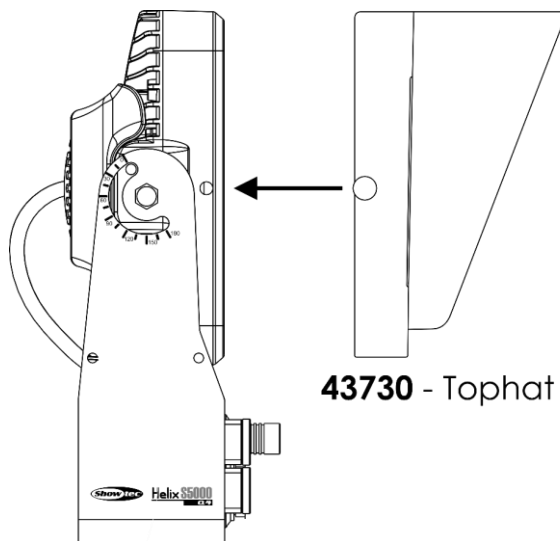

Fig. 09

- 02) Put the tophat on the device, as shown in Fig. 10.

- 03) Make sure that the 2 pins are aligned with the openings of the spring-loaded locking mechanism.



43730 - Tophat for Helix S5000 Q4

Fig. 10

- 04) Release both pins of the locking mechanism to lock the tophat in position.
- 05) Make sure that the pins of the locking mechanism are firmly locked in the openings on the sides of the device. For extra safety, use a safety cable to connect the tophat to the device.

Safety eye for a safety cable

43730 - Tophat for Helix S5000 Q4

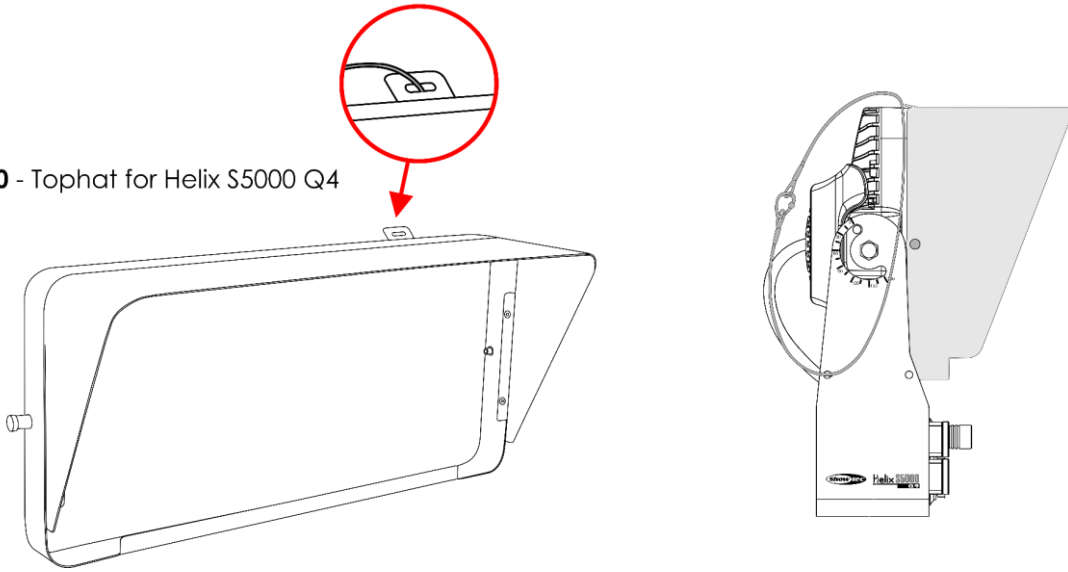

Fig. 11

4.7. Rigging

The device can be positioned on a flat surface (see Fig. 12) or mounted to a truss or other rigging structure in any orientation. Make sure that all loads are within the pre-determined limits of the supporting structure.



CAUTION
Restrict the access under the work area during rigging and/or derigging.

To mount the device, follow the steps below:

- 01) Use a clamp to attach the device to the supporting structure, as shown in Fig. 12. Make sure that the device cannot move freely. The use of a quick lock bracket is optional.
- 02) Secure the device with a secondary suspension, for example a safety cable. Make sure that the secondary suspension can hold 10 times the weight of the device. If possible, the secondary suspension should be attached to a supporting structure independent of the primary suspension. Put the safety cable through the **safety eye (09)**, as shown in Fig. 12. You can use the safety cable supplied with the device.

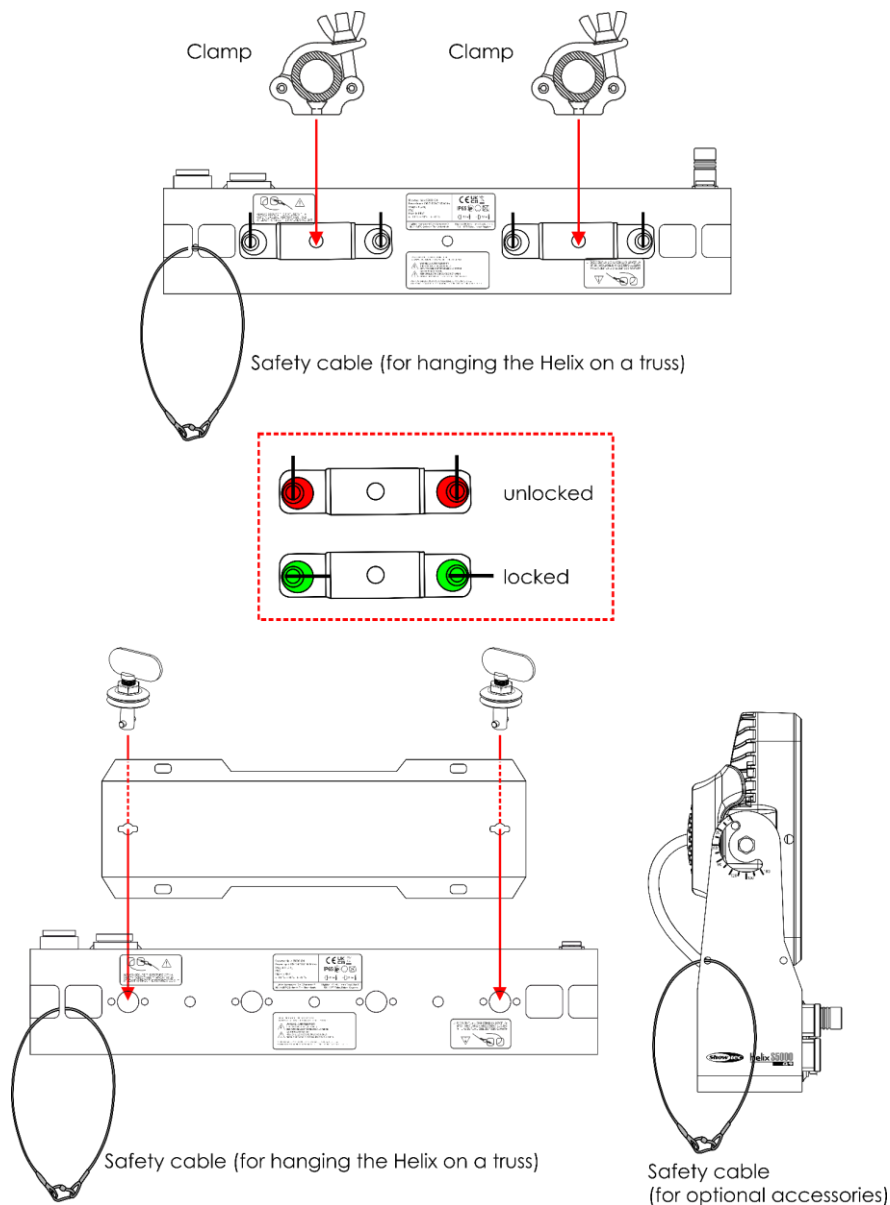

Fig. 12

4.7.1. Angle Adjustment

You can adjust the angle of the device with the 2 **adjustment screws (08)**.

- 01) Turn the **adjustment screws (08)** counterclockwise to release them.
- 02) Tilt the device at the desired angle (see Fig. 13).
- 03) Turn the **adjustment screws (08)** clockwise to tighten them. Make sure that the device cannot move freely after the **adjustment screws (08)** are tightened.

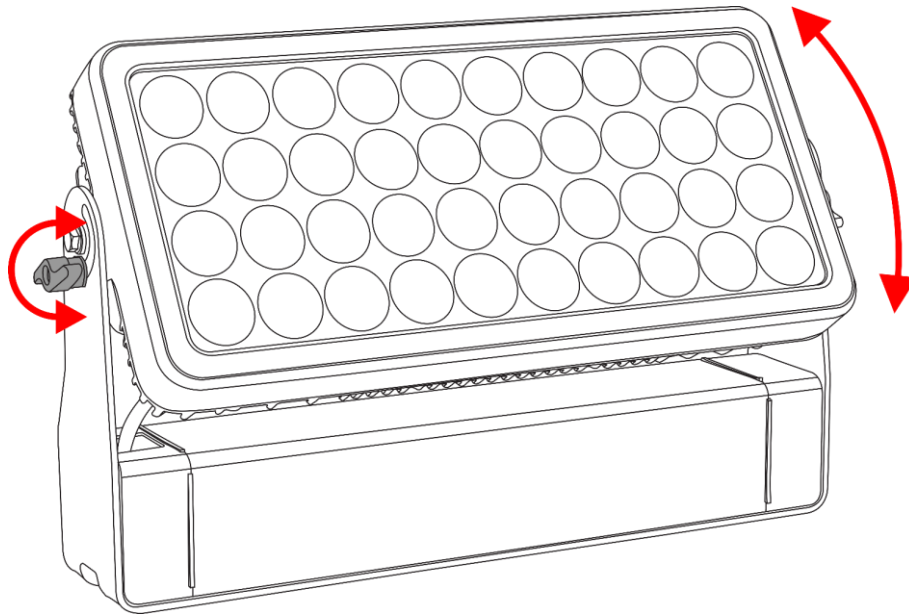

Fig. 13

4.8. Connecting to Power Supply



DANGER
Electric shock caused by short-circuit

The device accepts AC mains power at 100–240 V and 50/60 Hz. Do not supply power at any other voltage or frequency to the device.

This device falls under IEC protection class I. Make sure that the device is always electrically connected to the ground (earth).

Before connecting the device to the socket-outlet:

- Make sure that the power supply matches the input voltage specified on the information label on the device.
- Make sure that the socket-outlet has ground (earth) connection.

Connect the device to the socket-outlet with the power plug. Do not connect the device to a dimmer circuit, as this may damage the device.

This device is IP65 rated.

- Do not expose the device to conditions that exceed the rated IP class conditions.
- Keep the connectors sealed with the rubber caps when the connectors are not in use.
- Do not connect the cables from above the connectors, if the device is installed outdoors. Make a 'drip loop' in the cable so that rain water cannot enter the device.
- Make sure that the cable run is not too heavy. A heavy cable run can cause damage to the connectors. If the connectors are damaged, their ingress protection (IP) can deteriorate.

4.9. Power Linking of Multiple Devices

This device supports power linking. Power can be relayed to another device via the power OUT connector. Note that the input and the output connectors have different designs: one type cannot be connected to the other.

Power linking of multiple devices must be carried out only by instructed or skilled persons.



WARNING
Incorrect power linking may lead to overload of the electrical circuit and result in serious injuries and damage of property.

To prevent overload of the electrical circuit, when power linking multiple devices:

- Use cables with sufficient current-carrying capacity. The power cable supplied with the device is not suitable for power linking of multiple devices.
- Make sure that the total current draw of the device and all connected devices does not exceed the rated capacity of the power cables and the circuit breaker.
- Do not link more devices on one power link than the maximum recommended number.

Maximum recommended number of devices:

- at 100–120 V: 3 devices Helix S5000 10° IP65
- at 200–240 V: 7 devices Helix S5000 10° IP65

5. Setup

5.1. Warnings and Precautions



DANGER
Electric shock caused by short-circuit

This device is IP65 rated.

- Do not expose the device to conditions that exceed the rated IP class conditions.
- Keep the connectors sealed with the rubber caps when the connectors are not in use.
- Do not connect the cables from above the connectors, if the device is installed outdoors. Make a 'drip loop' in the cable so that rain water cannot enter the device.
- Make sure that the cable run is not too heavy. A heavy cable run can cause damage to the connectors. If the connectors are damaged, their ingress protection (IP) can deteriorate.



Attention
Connect all data cables before supplying power.
Disconnect power supply before connecting or disconnecting data cables.

5.2. Stand-alone Setup

When the Helix S5000 10° IP65 is not connected to a controller or to other devices, it functions as a stand-alone device.

For more information about the control modes, refer to **6.2. Control Modes** on pages 28–29.

5.3. DMX Connection

5.3.1. DMX-512 Protocol

You need a DMX serial data link to run light shows of one or more devices using a DMX-512 controller or to run synchronized shows of two or more devices set in a master/slave control mode.

The Helix S5000 10° IP65 has 5-pin DMX signal IN and OUT connectors.

The pin assignment is as follows:

- 5-pin: pin 1 (ground), pin 2 (-), pin 3 (+), pin 4 (N/C), pin 5 (N/C)

Devices on a serial data link must be daisy-chained in a single line. The number of devices that you can control on one data link is limited by the combined number of the DMX channels of the connected devices and the 512 channels available in one DMX universe.

To comply with the TIA-485 standard, no more than 32 devices should be connected on one data link. In order to connect more than 32 devices on one data link, you must use a DMX optically isolated splitter/booster, otherwise this may result in deterioration of the DMX signal.

Note:

- Maximum recommended DMX data link distance: 300 m
- Maximum recommended number of devices on a DMX data link: 32 devices

5.3.2. DMX Cables

Shielded twisted-pair cables with 5-pin XLR connectors must be used for reliable DMX connection. You can purchase DMX cables directly from your Highlite International dealer or make your own cables.

If you use 5-pin XLR audio cables for DMX data transmission, this may lead to signal degradation and unreliable operation of the DMX network.

When you make your own DMX cables, make sure that you connect the pins and wires correctly as shown in Fig. 14.

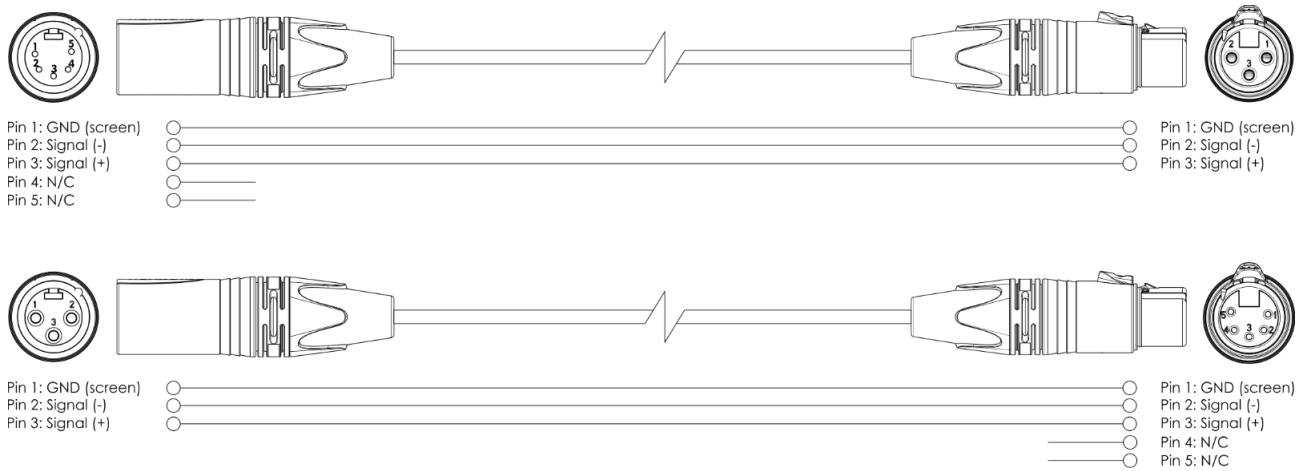

Fig. 14

5.3.3. Master/Slave Setup

The Helix S5000 10° IP65 supports master/slave control mode. To connect multiple devices in a master/slave setup, follow the steps below:

- 01) Connect the first device's DMX OUT connector to the second device's DMX IN connector with a 5-pin DMX cable. The first connected device in the setup will be automatically recognized as the master device.
- 02) Repeat step 1 to connect all devices as shown in Fig. 15.
- 03) Set all subsequent devices in the setup as slave devices. See **6.6.5 Slave Mode** on page 36 for more information.
- 04) Connect a DMX terminator (120 Ω resistor) to the DMX OUT connector of the last device in the setup.

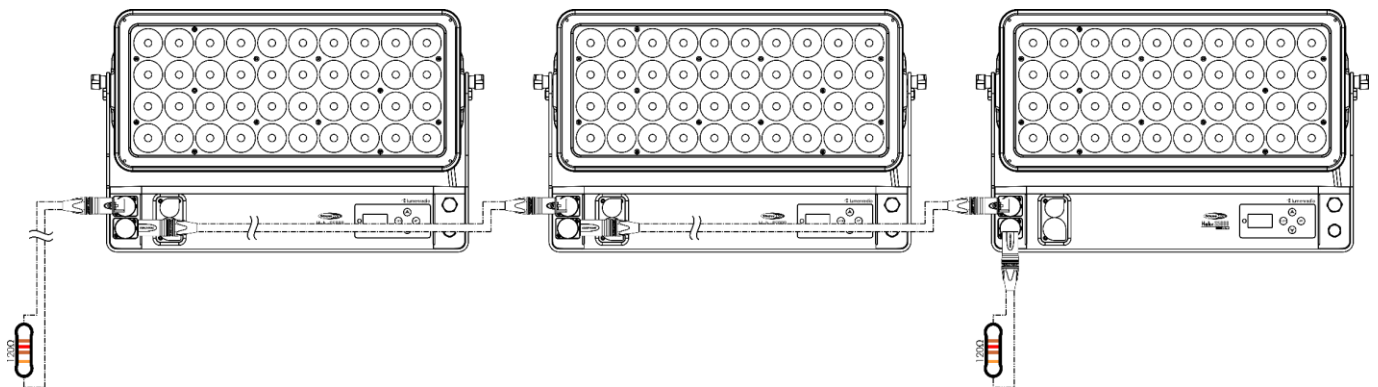

Fig. 15

5.3.4. DMX Linking

To connect multiple devices on one DMX data link, follow the steps below:

- 01) Use a 5-pin DMX cable to connect the DMX OUT connector of the lighting controller to the DMX IN connector of the first device.
- 02) Connect the first device's DMX OUT connector to the second device's DMX IN connector with a 5-pin DMX cable.
- 03) Repeat step 2 to connect all devices in a daisy-chain as shown in Fig. 16.
- 04) Connect a DMX terminator (120 Ω resistor) to the DMX OUT connector of the last device on the data link.

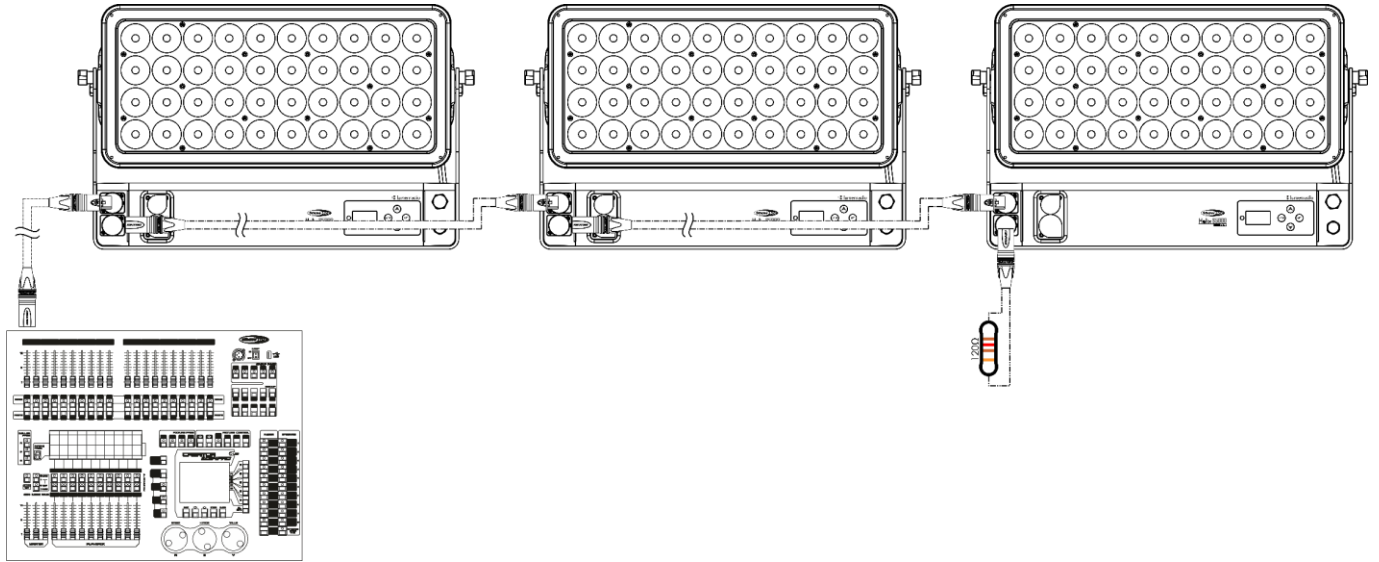

Fig. 16

5.3.5. DMX Addressing

In a setup with multiple devices, make sure that you set the DMX starting address of each device correctly. The Helix S5000 10° IP65 has 5 personalities: 4, 6, 8, 20, 24 channels.

If you want to connect multiple devices on one data link and use them in 24-channel mode, for example, follow the steps below:

- 01) Set the starting address of the 1st device on the data link to 1 (001).
- 02) Set the starting address of the 2nd device on the data link to 25 (025), as $1 + 24 = 25$.
- 03) Set the starting address of the 3rd device on the data link to 49 (049), as $25 + 24 = 49$.
- 04) Continue assigning the starting addresses of the remaining devices by adding each time 24 to the previous number.

Make sure that you do not have any overlapping channels in order to control the Helix S5000 10° IP65 correctly. If two or more devices are addressed similarly, they will work similarly.

5.3.6. Multiple Helixes (Wireless DMX Control)

You can use the Helix in a wireless DMX setup. Make sure the device is operating in wireless DMX mode, which can be set in the main menu (see **6.6.1.3. DMX Signal** on page 33 for more information).

5.3.6.1. LumenRadio 2.4GHz Wireless Communication Module

Communication distance:	depending on the transmitting power or transmitter module
Test conditions:	CRMX TRx Transmitter module, 2dBi Antenna, transmitting power 20dBm (100mW)
Range indoor:	60 m (approx. through three concrete walls)
Range outdoor:	250 m

5.3.6.2. Wireless DMX Connection

The wireless receiving module "Timo", provided by LumenRadio, only has a 2.4 GHz wireless signal receiving function. To establish a wireless connection, please use the ([52001](#)) BlackBox F-1 Tranceiver G6 by LumenRadio. To control the status of the wireless communication, please look at the green LED indicator light on the right-hand side of the display.

Note:

- When the Helix receives a wireless DMX signal, then this signal will also be present at its **5-pin XLR-HD connector (03)**. However, **the Helix has not been designed to send wireless signals**. Therefore, always connect the Helix devices to each other using a DMX cable.

5.3.6.3. Wireless DMX Problems

- The LED indicator will blink quickly: No signal from the CRMX transmitter
- The LED indicator will blink slowly: Proper connection with the CRMX transmitter, but no DMX signal is present.
- First time wireless linking does not work. This may be caused by too much interference from other wireless signals in combination with a large distance between the Helix and the Wireless DMX sender. Move them close together (less than 3m.) and start the initial linking process. After this has been done, move the Helix to the designated installation spot. The created link will remain.

When the wireless DMX communication is unhindered and a DMX signal is present, the LED indicator will always be on.

Note:

The Helix S5000 10° IP65 cannot receive a CRMX signal and a DMX cable signal at the same time.

When the device is in Auto mode or Built-in Programs mode, please make sure that the paired 2.4GHz wireless signal transmitter is OFF.

Note:

The Helix S5000 10° IP65 is only a CRMX receiver and never a wireless DMX transmitter.

5.3.6.4. Connect the Helix to the Wireless DMX Signal Transmitter

The Helix cannot actively match a random wireless signal transmitter. To pair the Helix with the wireless signal transmitter, please check the manual of the wireless signal transmitter you use. We advise you to use the BlackBox F-1 Transceiver G6 ([52001](#)) by LumenRadio.

5.3.6.5. Disconnect the Helix from the Wireless DMX Signal Transmitter

- 01) Turn off/unlink the CRMX. In order to do so, deactivate CRMX (see **6.6.1.4. CRMX Unlock** on page 33 for more information).
- 02) Unlink the Helix (see **6.6.1.4. CRMX Unlock** on page 33 for more information).
- 03) The Helix will now be disconnected.

5.3.6.6. Setup Example 1

The Helix cannot send any wireless signals. Therefore, the slave Helix fixtures must always be connected via a DMX signal cable.

Note:

The Helix S5000 10° IP65 is only a CRMX receiver and never a CRMX transmitter. When the Helix operates in DMX or Slave mode, it can receive a wireless DMX signal (CH1–512) and at the same time it can also send a DMX signal, via its **5-pin XLR-HD connector (03)**, through a DMX cable.

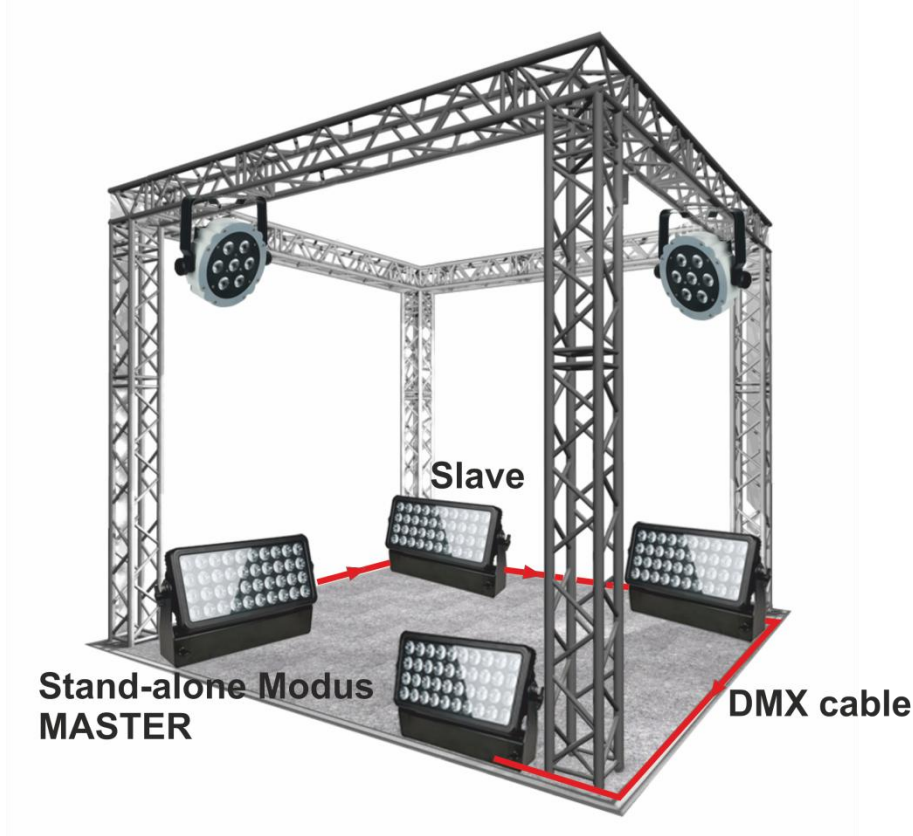

Fig. 17

5.3.6.7. Setup Example 2

Connect the Helix to the wireless DMX signal transmitter

The Helix S5000 10° IP65 cannot actively search for wireless signal transmitters. To pair the Helix with the wireless signal transmitter, please check the manual of the wireless signal transmitter you use. We advise you to use the BlackBox F-1 Tranceiver G6 ([52001](#)) by LumenRadio.

It is recommended to use the BlackBox F-1 Tranceiver G6 ([52001](#)) by LumenRadio.

Disconnect from the Wireless DMX signal transmitter

The Helix can be disconnected from the wireless DMX signal transmitter. It is possible to deactivate CRMX in the main menu, see **6.6.1.4. CRMX Unlock** on page 33 for more information.



Fig. 18

6. Operation

6.1. Safety Instructions for Operation



Attention

This device must be used only for the purposes it is designed for.

This device is intended for professional use as an outdoor spot. It is not suitable for households and for general lighting.

Any other use, not mentioned under intended use, is regarded as non-intended and incorrect use.



Attention

Power supply

Before connecting the device to the power supply, make sure that the current, voltage and frequency match the input voltage, current and frequency specified on the information label on the device.

6.2. Control Modes

The Helix S5000 10° IP65 can be operated with a DMX controller, or without a DMX controller as a stand-alone device or in a master/slave setup.

The Helix S5000 10° IP65 supports the following control modes:

- Stand-alone: Manual operation mode, auto operation mode (auto programs), built-in programs
- Master/Slave: Manual operation mode, auto operation mode (auto programs), built-in programs
- DMX-512: 5 channel modes (4, 6, 8, 20 and 24 channels)
- Wireless DMX / CRMX: 5 channel modes (4, 6, 8, 20 and 24 channels)

For more information about how to connect the devices, refer to **5. Setup** on pages 22–27.

To operate the device manually as a stand-alone device or in a master/slave setup:

Adjust the intensity values for the colors. See **6.6.2. Manual Mode** on page 34 for more information.

In auto operation mode you can run the auto program:

Select the auto program. See **6.6.3. Auto Mode** on page 34 for more information.

In Program Mode 01 you can select one of 38 static colors. To run this program:

- 01) Select Program Mode 01 in the Program menu.
- 02) Select one of the 38 static colors. See **6.6.4.1. Program 01 / Static colors** on page 35 for more information.
- 03) Add strobe effect. See **6.6.4.1. Program 01 / Static colors** on page 35 for more information.

In Program Mode 02–26 you can select one of the built-in programs. To run one of the built-in programs:

- 01) Select Program Mode 02–26 in the Program menu.
- 02) Select one of the 15 built-in chases. See **6.6.4.2. Program 02–26** on page 35 for more information.
- 03) Add strobe effect or adjust the chase speed. See **6.6.4.2. Program 02–26** on page 35 for more information.

To operate the device with a DMX controller:

- 01) Select DMX or CRMX mode in the DMX menu. See **6.6.1.3. DMX Signal** on page 33 for more information.
- 02) Set the DMX starting address of the device in the DMX Address menu. See **6.6.1.1. DMX Address** on page 32 for more information.
- 03) Select the DMX channel mode in the DMX Configuration menu. See **6.6.1.2. Channels** on page 33 for more information. See **6.7. DMX Channels** on pages 42–46 for complete overview of all DMX channels.

6.3. Control Panel

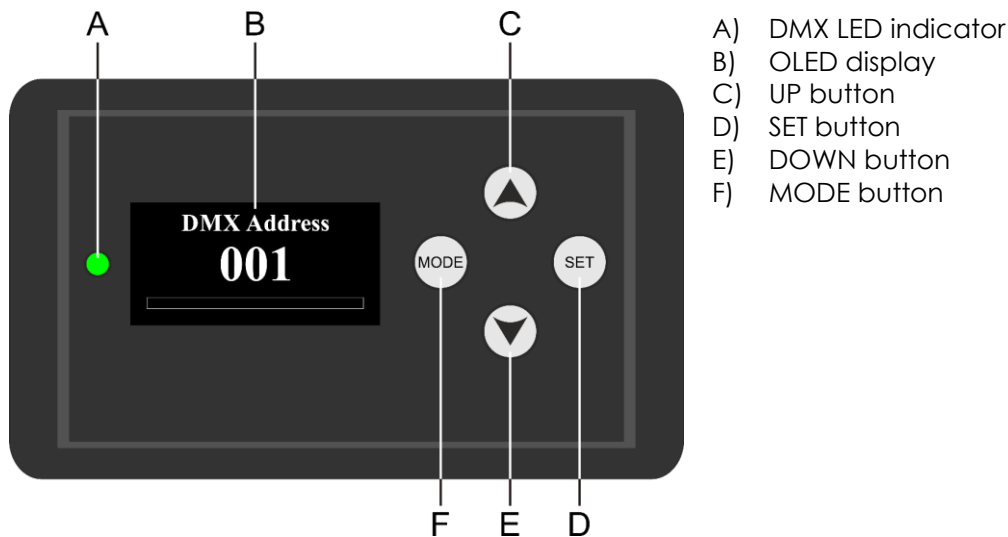

Fig. 19

- Use the **MODE** button to open the main menu or to exit the current submenu and return to the main menu.
- Use the **UP/DOWN** buttons to navigate through the menus or to increase/decrease numeric values.
- Use the **SET** button to open the desired menu, to confirm your choice or to set the currently selected value.

6.4. Start-up

Upon start-up the display shows the start screen. The start screen provides information about the software version, the temperature of the LEDs, the DMX starting address of the device, and the selected DMX channel mode:



Note:

If no button is pressed, after 30 seconds of inactivity the display will turn off. To unlock the display, you have to press and hold down the MODE and SET buttons for 3 seconds. Once you have pressed the buttons, the display will light up.

6.5. Menu Overview

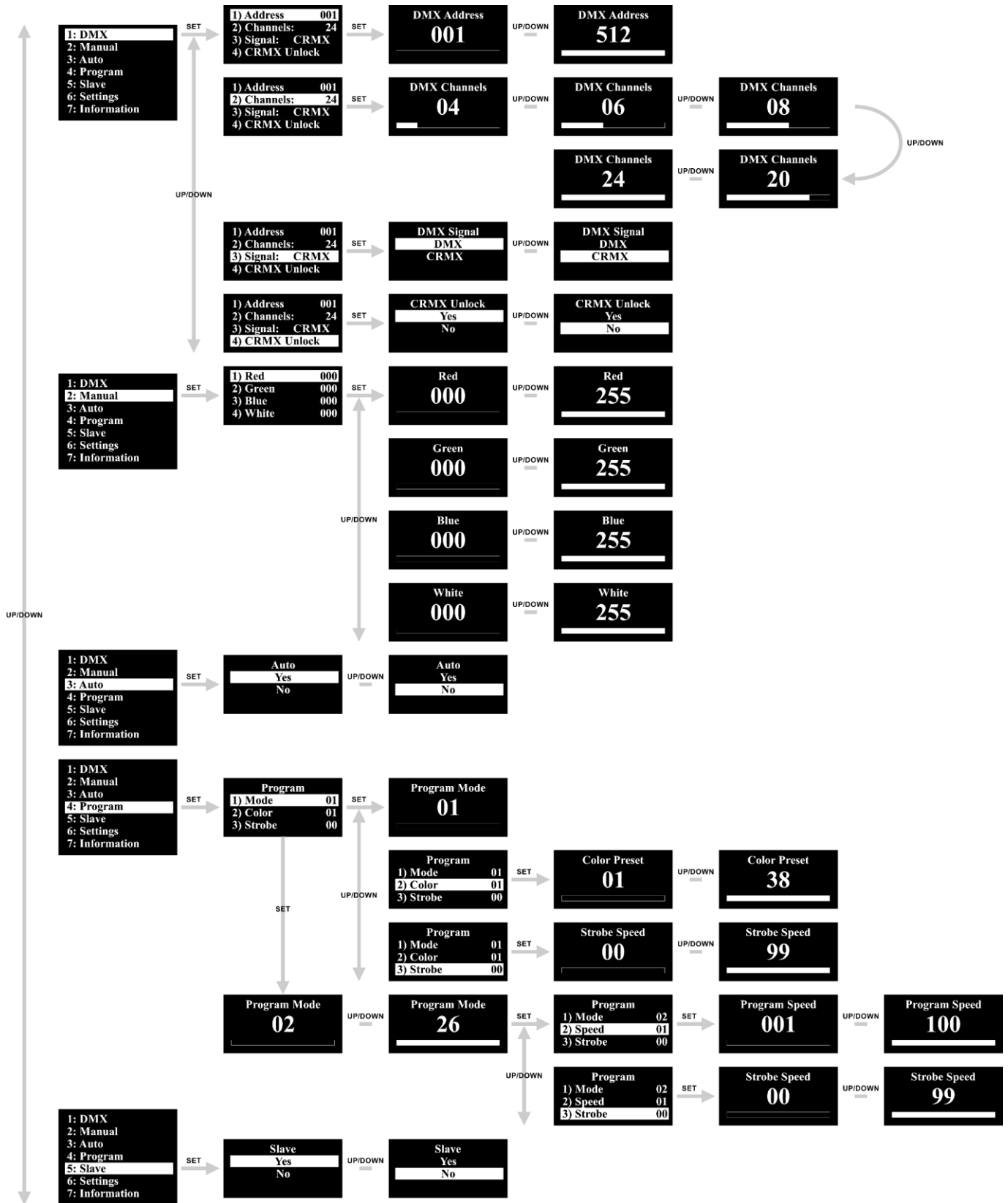

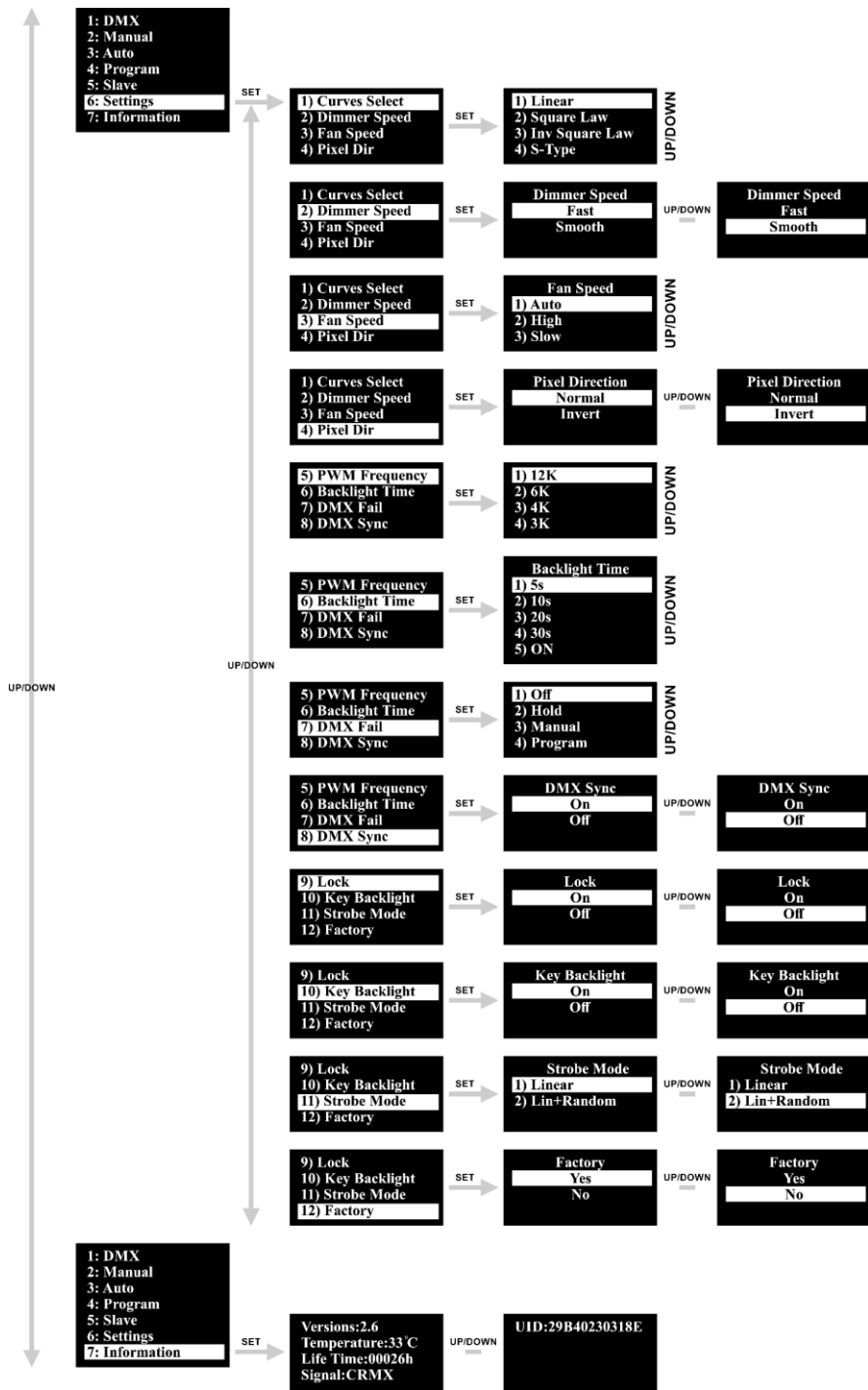

6.6. Main Menu Options

The main menu has the following options:

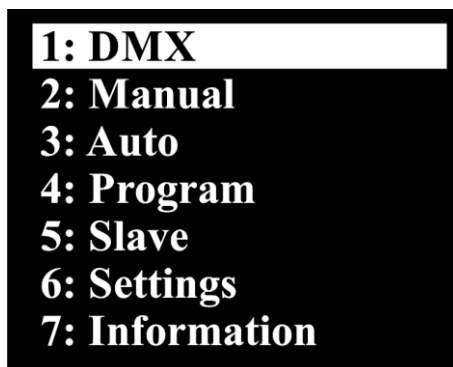

- 01) Press the **UP/DOWN** buttons to navigate through the main menu.
- 02) Press the **SET** button to open the submenu.

6.6.1. DMX Settings

In this menu you can set the DMX address, select the desired DMX mode and activate/deactivate the wireless DMX.

- 01) Press the **UP/DOWN** buttons to select one of the 4 submenus:
 - Address: See **6.6.1.1. DMX Address**
 - Channels: See **6.6.1.2. DMX Channels**
 - Signal: See **6.6.1.3. DMX Signal**
 - CRMX unlock: See **6.6.1.4. CRMX Unlock**

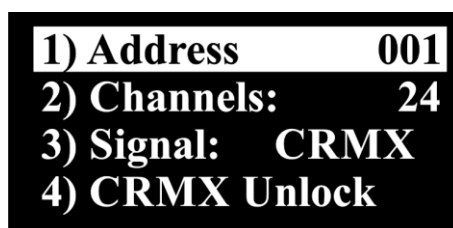

- 02) Press the **SET** button to confirm your choice.

6.6.1.1. DMX Address

In this menu you can set the DMX starting address of the device.

- 01) Press the **UP/DOWN** buttons to select the DMX starting address of the device. The selection range is 001–512. Refer to **5.3.5. DMX Addressing** on page 24 for more information.



- 02) Press the **SET** button to confirm your choice.

6.6.1.2. DMX Channels

In this menu you can set the desired DMX channel mode.



- 01) Press the **UP/DOWN** buttons to set the desired DMX channel mode. Select one of the 5 options:
- 4 channels
 - 6 channels
 - 8 channels
 - 20 channels
 - 24 channels

02) Press the **SET** button to confirm your choice.

Note:

See **6.7. DMX Channels** on pages 42–46 for complete overview of all DMX channels.

6.6.1.3. DMX Signal

In this menu you can set the DMX signal type.



- 01) Press the **UP/DOWN** buttons to set the desired DMX signal type. Select one of the 2 options:
- DMX: Conventional DMX
 - CRMX: Wireless DMX

02) Press the **SET** button to confirm your choice.

6.6.1.4. CRMX Unlock

In this menu you can unlock the wireless DMX.



- 01) Press the **UP/DOWN** buttons to select YES (to unlock the wireless DMX) or NO (to return to the previous screen).
- 02) Press the **SET** button to confirm your choice.

6.6.2. Manual Mode

In this menu you can manually set the desired color.

- 01) Press the **UP/DOWN** buttons to select the parameter.
- 02) Press the **SET** button to confirm the selection and open the submenu.
- 03) Press the **UP/DOWN** buttons to increase/decrease the values:

1) Red	000
2) Green	000
3) Blue	000
4) White	000

- **RED:** Set the intensity of the red color. The adjustment range is 0–255, from low to high intensity
- **GREEN:** Set the intensity of the green color. The adjustment range is 0–255, from low to high intensity
- **BLUE:** Set the intensity of the blue color. The adjustment range is 0–255, from low to high intensity
- **WHITE:** Set the intensity of the white color. The adjustment range is 0–255, from low to high intensity

- 04) You can combine Red, Green, Blue and White to create an infinite range of colors (0–255).
- 05) Press the **SET** button to confirm your choice.

6.6.3. Auto Mode

In this menu you can set Auto mode.

- 01) Press the **SET** button to enter the menu. The display will show:

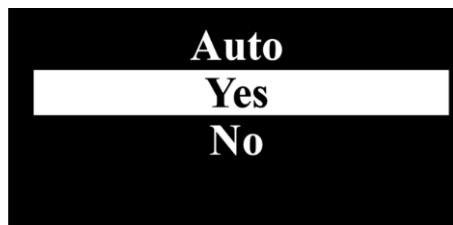

- 02) Press the **UP/DOWN** buttons to select YES (to start the auto show) or NO (to return to the previous screen).
- 03) Press the **SET** button to confirm your choice.

6.6.4. Built-in Programs Mode

In this menu you can set the built-in auto programs.

Press the **UP/DOWN** buttons to select one of the following options. The selection range is Program 01–Program 16:

- Program 01 You can select one of the static colors. See **6.6.4.1. Program 01** on page 35 for more information
- Program 02–26 You can select one of the built-in programs. See **6.6.4.2. Program 02–26** on page 35 for more information

6.6.4.1. Program 01 / Static Colors

01) If you have chosen program 01, the display will show:

Program	
1) Mode	01
2) Color	01
3) Strobe	00

02) Press the **UP/DOWN** buttons to select one of the 2 options:

- COLOR
- STROBE

03) Press the **SET** button to confirm the selection and open the desired submenu.

- If you have chosen COLOR, press the **UP/DOWN** buttons to select one of the 38 color macros. Press the **SET** button to save your settings.
- If you have chosen STROBE, press the **UP/DOWN** buttons to set the strobe frequency. The adjustment range is between 0–99, from OFF to high frequency. Press the **SET** button to save your settings.

6.6.4.2. Program 02–26

01) If you have chosen one of the programs 02–26, the display will show:

Program	
1) Mode	02
2) Speed	01
3) Strobe	00

02) Press the **UP/DOWN** buttons to select one of the 2 options:

- SPEED
- STROBE

03) Press the **SET** button to confirm the selection and open the desired submenu.

- If you have chosen SPEED, press the **UP/DOWN** buttons to set the built-in program's speed. The adjustment range is between 1–100, from slow to fast. Press the **SET** button to save your settings.
- If you have chosen STROBE, press the **UP/DOWN** buttons to set the strobe frequency. The adjustment range is between 0–99, from OFF to high frequency. Press the **SET** button to save your settings.

6.6.5. Slave Mode

In this menu you can set the slave mode of the device.

01) Press the **UP/DOWN** buttons to select one of the following 2 options:



02) Press the **SET** button to confirm your choice.

- If you have chosen YES, the device will be set as a slave and will react the same as the master device.

6.6.6. Settings

In this menu you can adjust the device's settings.

01) Press the **UP/DOWN** buttons to select one of the following 12 options:

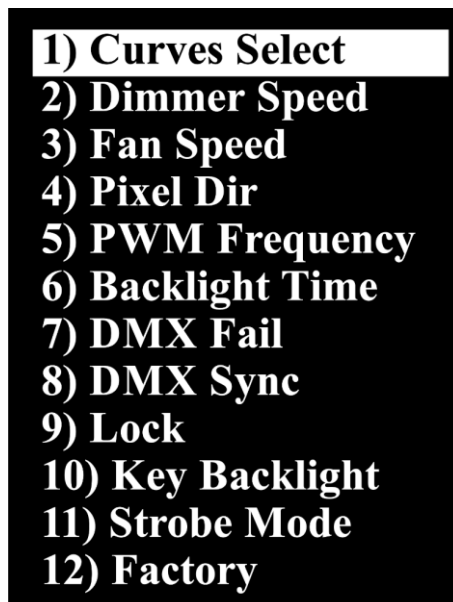

02) Press the **ENTER** button to confirm the selection.

6.6.6.1. Curves Select

In this menu you can set dimming curves.

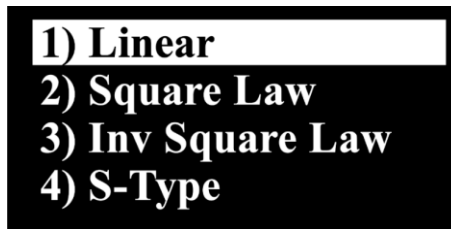

01) Press the **UP/DOWN** buttons to set the desired dimming curve. Select one of the 4 options:

- Linear
- Square Law
- Inv Square Law
- S-Type

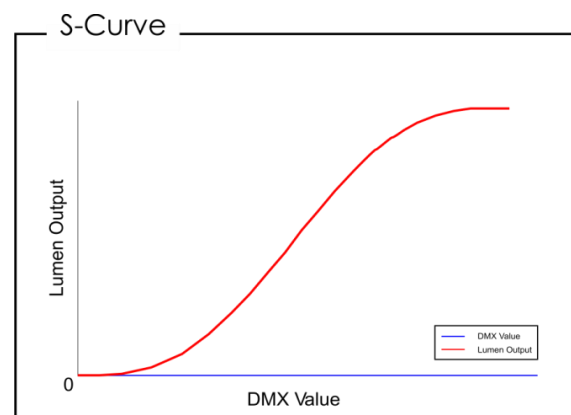
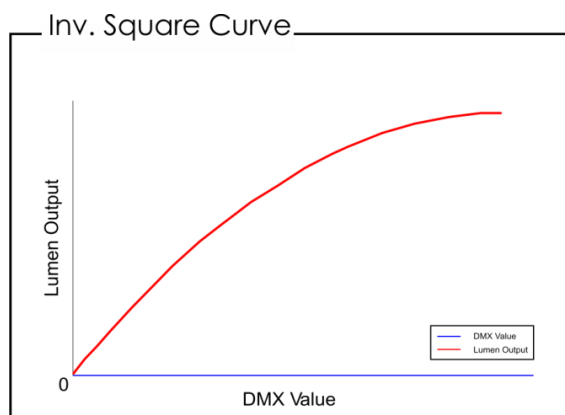
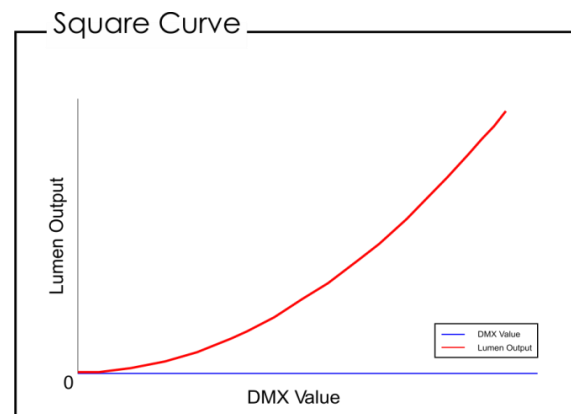
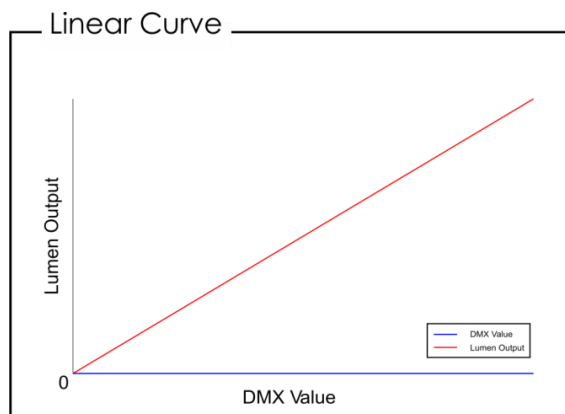

02) Press the **SET** button to confirm your choice.

6.6.6.2. Dimmer Speed

In this menu you can set the dimming speed.



- 01) Press the **UP/DOWN** buttons to set the desired dimming speed. Select one of the 2 options:
 - Fast: Output will follow DMX dimmer value directly
 - Smooth: Output will follow DMX dimmer value with fade time to create smooth transitions
- 02) Press the **SET** button to confirm your choice.

6.6.6.3. Fan Speed

In this menu you can set the fan speed.



- 01) Press the **UP/DOWN** buttons to select AUTO, HIGH or SLOW.
- 02) Press the **SET** button to confirm your choice.

6.6.6.4. Pixel Dir

In this menu you can set the pixel direction.

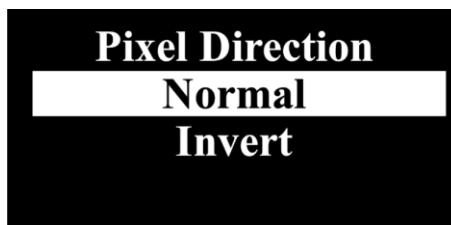

- 01) Press the **UP/DOWN** buttons to select NORMAL or INVERT.
- 02) Press the **SET** button to confirm your choice.

6.6.6.5. PWM Frequency

In this menu you can set the PWM frequency.

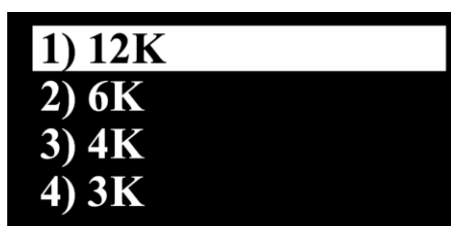

- 01) Press the **UP/DOWN** buttons to select 12K, 6K, 4K or 3K.
- 02) Press the **SET** button to confirm your choice.

6.6.6.6. PWM Frequency

In this menu you can set the time which needs to pass before the display turns off, when no buttons are pressed.

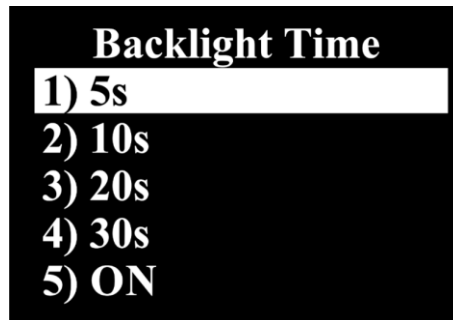

- 01) Press the **UP/DOWN** buttons to select 5s, 10s, 20s, 30s or ON (display continuously on).
 02) Press the **SET** button to confirm your choice.

6.6.6.7. DMX Fail

In this menu you can set the device's behavior in case of a DMX failure.

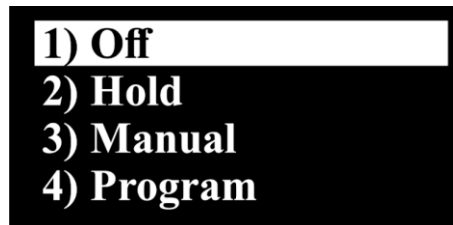

- 01) Press the **UP/DOWN** buttons to set the desired DMX Fail option. Select one of the 4 options:
- OFF: The device will black out the light output
 - HOLD: The device will use last properly received DMX signal, ensuring uninterrupted performance
 - MANUAL: The device will switch to Manual mode
 - PROGRAM: The device will run the built-in programs
- 02) Press the **SET** button to confirm your choice.

6.6.6.8. DMX Sync

In this menu you can set the Sync behavior of the device, while using multiple Helixes.

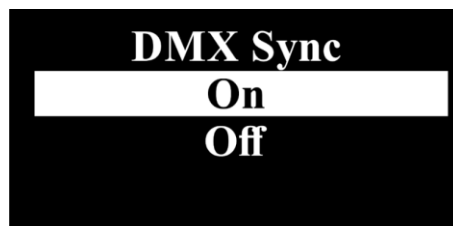

- 01) Press the **UP/DOWN** buttons to set the desired DMX sync option. Choose one of the 2 options:
- ON: all Helix devices will simultaneously perform the same action, without any delays
 - OFF: risk of random delays
- 02) Press the **SET** button to confirm your choice.

6.6.6.9. Lock

In this menu you can set the safety lock, restricting access to the main menu.



- 01) Press the **UP/DOWN** buttons to set the desired safety lock. Choose one of the 2 options:
 - **ON:** When no button is pressed within 30 seconds, the device's main menu will be locked. To unlock it, press and hold down the **MODE** and **SET** buttons for 3 seconds.
 - **OFF:** Safety lock is inactive.

02) Press the **SET** button to confirm your choice.

6.6.6.10. Key Backlight

In this menu you can set whether the 4 buttons (**MODE**, **SET**, **UP**, **DOWN**) will be illuminated or not.

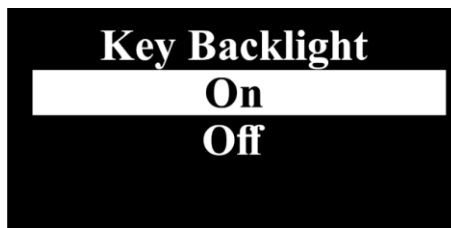

- 01) Press the **UP/DOWN** buttons to select **ON** or **OFF**.
- 02) Press the **SET** button to confirm your choice.

6.6.6.11. Strobe Mode

In this menu you can set the strobe mode.

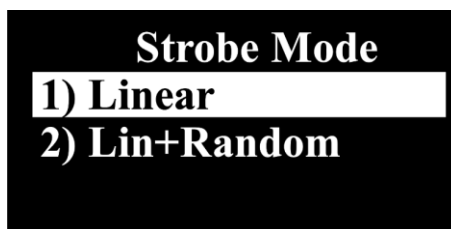

- 01) Press the **UP/DOWN** buttons to select **LINEAR** or **LIN+RANDOM**.
- 02) Press the **SET** button to confirm your choice.

6.6.6.12. Factory Reset

In this menu you can restore the default factory settings of the device.



01) Press the **UP/DOWN** buttons to select one of the 2 options:

- YES: Restore to factory default settings
- NO: Keep current settings, no factory reset.

02) Press the **SET** button to confirm your choice.

6.6.7. Information

In this menu you can see the device's current software version, temperature, total lifetime, type of DMX signal and the device's UID number.

01) Press the **SET** button to enter the menu. The display will show:



02) Press the **UP/DOWN** buttons to toggle through the screens.

6.7. DMX Channels

6.7.1. 4 channels, 6 channels

4 CH	6 CH	Function	Value	Setting
	1	Master Dimmer	000–255	From low to high intensity (0–100 %)
1	2	Red	000–255	From low to high intensity (0–100 %)
2	3	Green	000–255	From low to high intensity (0–100 %)
3	4	Blue	000–255	From low to high intensity (0–100 %)
4	5	White	000–255	From low to high intensity (0–100 %)
	6	Strobe ONLY when 6.6.6.11. Strobe Mode is set to LIN+RANDOM	000–004	No function
			005–127	Linear strobe flash frequency, from OFF to highest frequency
			128–189	All LEDs, random strobe flash frequency, from OFF to highest frequency
			190–255	Sectional LEDs, random strobe flash frequency, from OFF to highest frequency
	6	Strobe ONLY when 6.6.6.11. Strobe Mode is set to LINEAR	000–010	No function
			011–255	Strobe flash frequency, from OFF to highest frequency

Note:

Make sure that the Master Dimmer channel is open to see the light output.

6.7.2. 8 channels

8 CH	Function	Value	Setting
1	Master Dimmer	000–255	From low to high intensity (0–100 %)
2	Red	000–255	From low to high intensity (0–100 %)
3	Green	000–255	From low to high intensity (0–100 %)
4	Blue	000–255	From low to high intensity (0–100 %)
5	White	000–255	From low to high intensity (0–100 %)
6	Color switch/flow	000–005	No function
		006–015	Color switch 1
		016–025	Color switch 2
		026–035	Color switch 3
		036–045	Color switch 4
		046–055	Color switch 5
		056–065	Color switch 6
		066–075	Color switch 7
		076–085	Color switch 8
		086–095	Color flow 1
		096–105	Color flow 2
		106–115	Color flow 3
		116–125	Color flow 4
		126–135	Color flow 5
		136–145	Color flow 6
		146–155	Color flow 7
		156–165	Section switch 1
		166–175	Section switch 2
		176–185	Section switch 3
		186–195	Section switch 4
196–205	Section switch 5		
206–215	Section flow 1		

8 CH	Function	Value	Setting
		216–225	Section flow 2
		226–235	Section flow 3
		236–245	Section flow 4
		246–255	Section flow 5
7	Color switch/flow speed CH6 must be set between 6-255	000–255	From slow to fast (0–100 %)
7	Color macros CH1 must be open; CH6 must be closed	000–010	No function
		011–016	Red
		017–022	Flame Red
		023–028	Deep Gold Amber
		029–034	Millennium Gold
		035–040	Gold Amber
		041–046	Yellow
		047–052	Chrome Yellow
		053–058	Deep Amber
		059–064	Spring Yellow
		065–070	Lime Green
		071–076	JAS Green
		077–082	Fern Green
		083–088	Moss Green
		089–094	Primary Green
		095–100	Dark Green
		101–106	Green
		107–112	Medium Blue Green
		113–118	Light Blue
		119–124	Lighter Blue
		125–130	Steel Blue
		131–136	½ CT Blue
		137–142	Full CT Blue
		143–148	State Blue
		149–154	Double CT Blue
		155–160	Medium Blue
		161–166	Just Blue
		167–172	Deep Blue
		173–178	Blue
		179–184	Congo Blue
		185–190	Surprise Pink
		191–196	Fuchsia Pink
		197–202	Follies Pink
203–208	Special Rose Pink		
209–214	Pink		
215–220	Moroccan Pink		
221–226	Warm White		
227–232	Cold White		
233–255	Open White		
8	Strobe ONLY when 6.6.6.11 Strobe Mode is set to LIN+RANDOM	000–004	No function
		005–127	Linear strobe flash frequency, from OFF to highest frequency
		128–189	All LEDs, random strobe flash frequency, from OFF to highest frequency
		190–255	Sectional LEDs, random strobe flash frequency, from OFF to highest frequency

8 CH	Function	Value	Setting
8	Strobe ONLY when 6.6.6.11. Strobe Mode is set to LINEAR	000-010 011-255	No function Strobe flash frequency, from OFF to highest frequency

Note:

Make sure that the Master Dimmer channel is open in order to see the light output.

6.7.3. 20 channels, 24 channels

The Helix's output is divided into 5 sections.

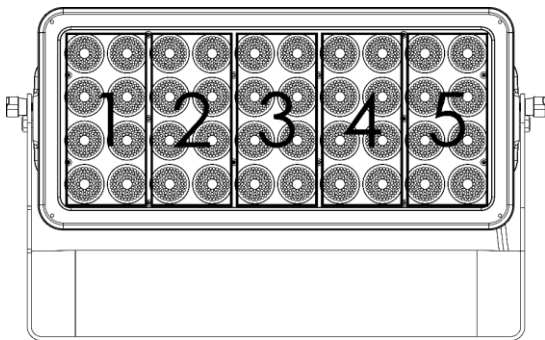

20 CH	24 CH	Function	Value	Setting
	1	Master Dimmer	000-255	From low to high intensity (0-100 %)
	2	Strobe ONLY when 6.11 Strobe Mode is set to LIN+RANDOM	000-004	No function
			005-127	Linear strobe flash frequency, from OFF to highest frequency
			128-189	All LEDs, random strobe flash frequency, from OFF to highest frequency
		190-255	Sectional LEDs, random strobe flash frequency, from OFF to highest frequency	
	2	Strobe ONLY when 6.11 Strobe Mode is set to LINEAR	000-010	No function
			011-255	Strobe flash frequency, from OFF to highest frequency
	3	Color switch/flow speed CH4 must be set between 6-255	000-255	From slow to fast (0-100 %)
	3	Color macros CH1 must be open; CH6 must be closed	000-010	No function
			011-016	Red
			017-022	Flame Red
			023-028	Deep Gold Amber
			029-034	Millennium Gold
			035-040	Gold Amber
			041-046	Yellow
			047-052	Chrome Yellow
			053-058	Deep Amber
			059-064	Spring Yellow
			065-070	Lime Green

		071-076	JAS Green
		077-082	Fern Green
		083-088	Moss Green
		089-094	Primary Green
		095-100	Dark Green
		101-106	Green
		107-112	Medium Blue Green
		113-118	Light Blue
		119-124	Lighter Blue
		125-130	Steel Blue
		131-136	½ CT Blue
		137-142	Full CT Blue
		143-148	State Blue
		149-154	Double CT Blue
		155-160	Medium Blue
		161-166	Just Blue
		167-172	Deep Blue
		173-178	Blue
		179-184	Congo Blue
		185-190	Surprise Pink
		191-196	Fuchsia Pink
		197-202	Follies Pink
		203-208	Special Rose Pink
		209-214	Pink
		215-220	Moroccan Pink
		221-226	Warm White
		227-232	Cold White
		233-255	Open White
4	Color macros CH1 must be open; CH6 must be closed	000-005	No function
		006-015	Color switch 1
		016-025	Color switch 2
		026-035	Color switch 3
		036-045	Color switch 4
		046-055	Color switch 5
		056-065	Color switch 6
		066-075	Color switch 7
		076-085	Color switch 8
		086-095	Color flow 1
		096-105	Color flow 2
		106-115	Color flow 3
		116-125	Color flow 4
		126-135	Color flow 5
		136-145	Color flow 6
		146-155	Color flow 7
		156-165	Section switch 1
		166-175	Section switch 2
		176-185	Section switch 3
		186-195	Section switch 4
		196-205	Section switch 5
		206-215	Section flow 1
		216-225	Section flow 2
		226-235	Section flow 3
		236-245	Section flow 4
		246-255	Section flow 5
		246-255	Section flow 5

1	5	Red (section 1)	000-255	From low to high intensity (0-100 %)
2	6	Green (section 1)	000-255	From low to high intensity (0-100 %)
3	7	Blue (section 1)	000-255	From low to high intensity (0-100 %)
4	8	White (section 1)	000-255	From low to high intensity (0-100 %)
5	9	Red (section 2)	000-255	From low to high intensity (0-100 %)
6	10	Green (section 2)	000-255	From low to high intensity (0-100 %)
7	11	Blue (section 2)	000-255	From low to high intensity (0-100 %)
8	12	White (section 2)	000-255	From low to high intensity (0-100 %)
9	13	Red (section 3)	000-255	From low to high intensity (0-100 %)
10	14	Green (section 3)	000-255	From low to high intensity (0-100 %)
11	15	Blue (section 3)	000-255	From low to high intensity (0-100 %)
12	16	White (section 3)	000-255	From low to high intensity (0-100 %)
13	17	Red (section 4)	000-255	From low to high intensity (0-100 %)
14	18	Green (section 4)	000-255	From low to high intensity (0-100 %)
15	19	Blue (section 4)	000-255	From low to high intensity (0-100 %)
16	20	White (section 4)	000-255	From low to high intensity (0-100 %)
17	21	Red (section 5)	000-255	From low to high intensity (0-100 %)
18	22	Green (section 5)	000-255	From low to high intensity (0-100 %)
19	23	Blue (section 5)	000-255	From low to high intensity (0-100 %)
20	34	White (section 5)	000-255	From low to high intensity (0-100 %)

Note:

Make sure that the Master Dimmer channel is open to see the light output.

6.8. RDM Information

This device supports RDM. Refer to **6.8.2. Supported RDM PIDs (Parameter IDs)** for more information.

6.8.1. RDM Details

- Responder: 29B4:023xxxxx
- Manufacturer's ID: Showtec (Highlite International B.V.)
- Manufacturer Label: Showtec
- Model Description: Helix S5000
- Model ID: 35
- Device Label: Helix S5000

6.8.2. Supported RDM PIDs (Parameter IDs)

Parameter ID	Value	Required	GET	SET
DISC_UNIQUE_BRANCH	0x0001	*		
DISC_MUTE	0x0002	*		
DISC_UN_MUTE	0x0003	*		
SUPPORTED_PARAMETERS	0x0050	*	*	
DEVICE_INFO	0x0060	*	*	
DEVICE_MODEL_DESCRIPTION	0x0080		*	
MANUFACTURER_LABEL	0x0081		*	
DEVICE_LABEL	0x0082		*	*
FACTORY_DEFAULTS	0x0090		*	*
SOFTWARE_VERSION_LABEL	0x00C0	*	*	
DMX_PERSONALITY	0x00E0		*	*
DMX_PERSONALITY_DESCRIPTION	0x00E1		*	
DMX_START_ADDRESS	0x00F0	*	*	*
SENSOR_DEFINITION	0x0200		*	
SENSOR_VALUE	0x0201		*	*
IDENTIFY_DEVICE	0x1000	*	*	*
RESET_DEVICE	0x1001			*

6.8.3. Highlite RDM Details

All Highlite RDM responder IDs are divided into 3 parts, starting with a 4-digit Manufacturer's ID, followed by a 3-digit Model ID, and a 5-digit unique ID for each item.

As a result, RDM responder IDs will always start with the same 7 digits (exclusive to each type of device). The last 5 digits will be different for each device.

7. Troubleshooting

This troubleshooting guide contains solutions to problems which can be carried out by an ordinary person. The device does not contain user-serviceable parts.

Unauthorized modifications to the device will render the warranty void. Such modifications may result in injuries and material damage.

Refer servicing to instructed or skilled persons. Contact your Highlite International dealer in case the solution is not described in the table.

Problem	Probable cause(s)	Solution
The device does not function at all	No power to the device	<ul style="list-style-type: none"> Check if power is switched on and cables are plugged in
	Internal fuse is blown	<ul style="list-style-type: none"> Disconnect the device and contact your Highlite International dealer
The device responds erratically	The factory settings of the device are changed	<ul style="list-style-type: none"> Reset the parameters of the device to the default factory settings. See 6.6.6.12. Factory Reset on page 41
The device does not respond to DMX control	The controller is not connected	<ul style="list-style-type: none"> Connect the controller
	The signal is reversed. The 5-pin DMX OUT of the controller does not match the DMX IN of the device	<ul style="list-style-type: none"> Install a phase-reversing cable between the controller and the device
	The controller is defective	<ul style="list-style-type: none"> Try using another controller
The device responds erratically to DMX control	Bad data link connection	<ul style="list-style-type: none"> Examine connections and cables. Correct poor connections. Repair or replace damaged cables
	The data link is not terminated with a 120 Ω termination plug	<ul style="list-style-type: none"> Insert a termination plug in the DMX OUT connector of the last device on the link
	Incorrect addressing	<ul style="list-style-type: none"> Check address settings and correct, if necessary
	In case of a setup with multiple devices, one of the devices is defective and disturbs data transmission on the link	<ul style="list-style-type: none"> To find out which device is defective, bypass one device at a time until normal operation is restored
No light or LEDs cut out intermittently	LEDs are damaged	<ul style="list-style-type: none"> Disconnect the device and contact your Highlite International dealer
	The power supply settings do not match local AC voltage and frequency	<ul style="list-style-type: none"> Disconnect the device. Check the settings and correct, if necessary

8. Maintenance

8.1. Safety Instructions for Maintenance



DANGER
Electric shock caused by dangerous voltage inside

Disconnect power supply before servicing or cleaning.

8.2. Preventive Maintenance



Attention
Before each use, examine the device visually for any defects.

Make sure that:

- All screws used for installing the device or parts of the device are tightly fastened and are not corroded.
- The safety devices are not damaged.
- There are no deformations on housings, fixations and installation points.
- The lens is not cracked or damaged.
- The power cables are not damaged and do not show any material fatigue.

8.2.1. Basic Cleaning Instructions

The external lens of the device must be cleaned periodically in order to optimize the light output. The cleaning schedule depends on the conditions at the site where the device is installed. When smoke or fog machines are used at the site, the device will need more frequent cleaning. On the other hand, if the device is installed in well-ventilated area, it will need less frequent cleaning. To establish a cleaning schedule, examine the device at regular intervals during the first 100 hours of operation.

To clean the device, follow the steps below:

- 01) Disconnect the device from the electrical power supply.
- 02) Allow the device to cool down for at least 5 minutes.
- 03) Remove the dust collected on the external surface with dry compressed air and a soft brush.
- 04) Clean the lens with a damp cloth. Use a mild detergent solution.
- 05) Dry the lens carefully with a lint-free cloth.
- 06) Clean the DMX and other connections with a damp cloth.



Attention

- Do not immerse the device in liquid.
- Do not use alcohol or solvents.
- Make sure that the connections are fully dry before connecting the device to the power supply and to other devices.

8.2.2. Draining Condensation Water

The Helix S5000 10° IP65 is IP65 rated. The device can resist water jets. If the device is exposed to extreme humid conditions during servicing, condensation may collect inside the device. This can happen also during transportation, if the device is exposed to extreme temperature variations.

If condensation water collects inside the device, follow the steps bellow to remove the condensation water:

01) Carefully remove the **protective vent (07)** with a wrench (16 mm).

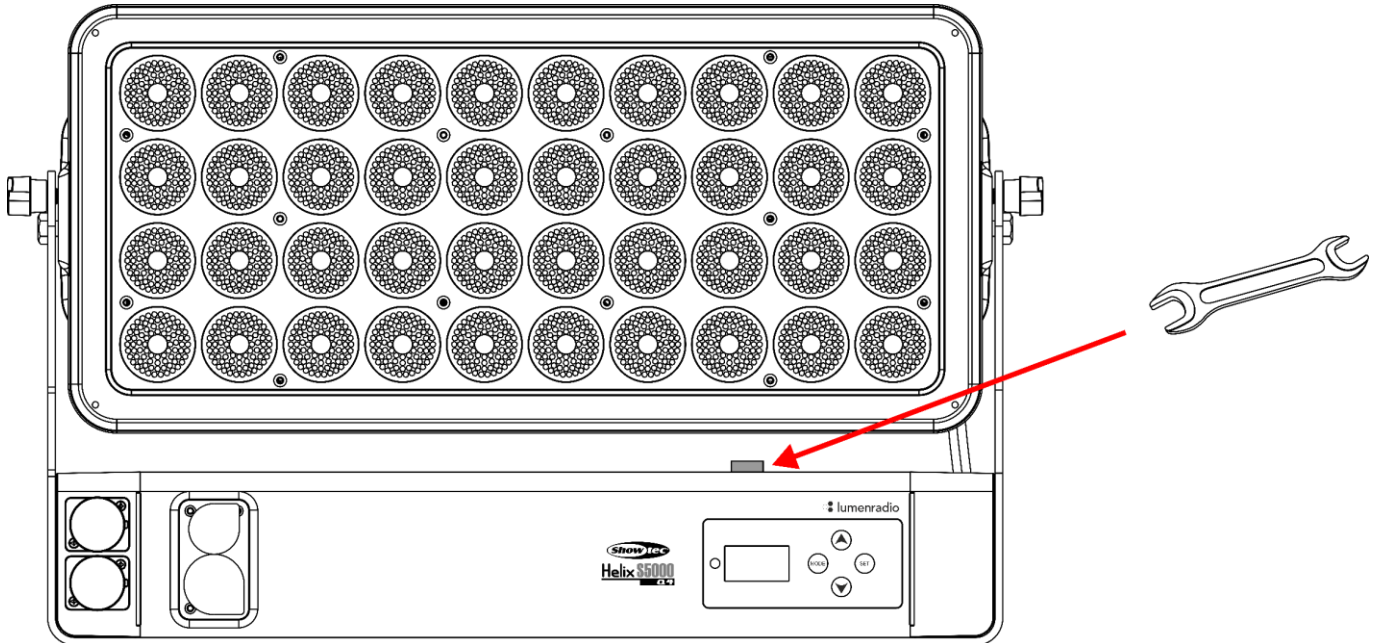

Fig. 20

02) Let the device operate at full output for 60 minutes.

03) Let the device cool down for 30 minutes.

04) Install the **protective vent (07)** back in place. Make sure that you do not overtighten it.

8.3. Corrective Maintenance

The device does not contain user-serviceable parts. Do not open the device and do not modify the device.

Refer repairs and servicing to instructed or skilled persons. Contact your Highlite International dealer for more information.

9. Deinstallation, Transportation and Storage

9.1. Instructions for Deinstallation



WARNING

Incorrect deinstallation can cause serious injuries and damage of property.

- Let the device cool down before dismounting.
- Disconnect power supply before deinstallation.
- Always observe the national and site-specific regulations during deinstallation and derigging of the device.
- Wear personal protective equipment in compliance with the national and site-specific regulations.

9.2. Instructions for Transportation

- Use the original packaging to transport the device, if possible.
- Always observe the handling instructions printed on the outer carton box, for example: "Handle with care", "This side up", "Fragile".

9.3. Storage

- Clean the device before storing. Follow the cleaning instructions in chapter **8.2.1. Basic Cleaning Instructions** on page 49.
- Store the device in the original packaging, if possible.

10. Disposal

Correct disposal of this product



Waste Electrical and Electronic Equipment

This symbol on the product, its packaging or documents indicates that the product shall not be treated as household waste. Dispose of this product by handing it to the respective collection point for recycling of electrical and electronic equipment. This is to avoid environmental damage or personal injury due to uncontrolled waste disposal. For more detailed information about recycling of this product contact the local authorities or the authorized dealer.

11. Approval



Hereby, Highlite International declares that the device Helix S5000, product code 43724, is in compliance with Directive 2014/53/EU (RED – Radio Equipment Directive).

The full text of the EU declaration of conformity is available on the respective product page on the website of Highlite International (www.highlite.com).



©2023 Showtec