

Raccoon P7/7

Product code: 200550

Firmware: 2.04/9933

Preface

Thank you for purchasing this Infinity product.

The purpose of this user manual is to provide instructions for the correct and safe use of this product.

Keep the user manual for future reference as it is an integral part of the product. The user manual shall be stored at an easily accessible location.

This user manual contains information concerning:

- Safety instructions
- Intended and non-intended use of the device
- Installation and operation of the device
- Maintenance procedures
- Troubleshooting
- Transport, storage and disposal of the device

Non-observance of the instructions in this user manual may result in serious injuries and damage of property.

©2025 Infinity. All rights reserved.

No part of this document may be copied, published or otherwise reproduced without the prior written consent of Highlite International.

Design and product specifications are subject to change without prior notice.

For the latest version of this document or other language versions, please visit our website www.highlite.com or contact us at service@highlite.com.

Highlite International and its authorized service providers are not liable for any injury, damage, direct or indirect loss, consequential or economic loss or any other loss arising from the use of, or inability to use or reliance on the information contained in this document.

Highlite International B.V. – Vestastraat 2 – 6468 EX Kerkrade – the Netherlands

Table of contents

1. Introduction	4
1.1. Before Using the Product.....	4
1.2. Intended Use.....	4
1.3. LEDs Lifespan.....	4
1.4. Text Conventions.....	4
1.5. Symbols and Signal Words.....	5
1.6. Symbols on the Information Label.....	5
2. Safety	6
2.1. Warnings and Safety Instructions.....	6
2.2. Requirements for the User.....	8
2.3. Personal Protective Equipment.....	8
3. Description of the Device	9
3.1. Front view.....	9
3.2. Back View.....	9
3.3. Product Specifications.....	10
3.4. Dimensions.....	11
3.5. Optional Accessories.....	11
4. Installation	12
4.1. Safety Instructions for Installation.....	12
4.2. Personal Protective Equipment.....	12
4.3. Installation Site Requirements.....	12
4.4. Rigging.....	12
4.5. Angle Adjustment.....	13
4.6. Installation of Accessories.....	13
4.6.1. Accessory Holder Installation.....	14
4.6.2. Barndoor Installation.....	14
4.6.3. Top Hat Installation.....	15
4.6.4. Diffuser Installation.....	15
4.7. Connecting to Power Supply.....	16
4.8. Power Linking of Multiple Devices.....	16
5. Setup	17
5.1. Warnings and Precautions.....	17
5.2. Stand-alone Setup.....	17
5.3. DMX Connection.....	17
5.3.1. DMX-512 Protocol.....	17
5.3.2. DMX Cables.....	17
5.3.3. DMX Linking.....	18
5.3.4. DMX Addressing.....	19
6. Operation	20
6.1. Safety Instructions for Operation.....	20
6.2. Control Modes.....	20
6.3. Control Panel.....	21
6.4. Start-up.....	21
6.5. Menu Overview.....	22
6.6. Main Menu Options.....	24
6.6.1. DMX Mode.....	25
6.6.2. DMX Address.....	25
6.6.3. Manual Mode.....	26
6.6.3.1. Static Color Mode.....	26
6.6.3.2. Built-in Effects.....	26
6.6.4. Dimmer Curve.....	27
6.6.5. Dimmer Speed.....	27
6.6.6. Color Space.....	28
6.6.7. Tungsten.....	29
6.6.8. LED Mode.....	29
6.6.9. Calibration.....	30
6.6.10. LED Frequency.....	30

6.6.11. Display.....	30
6.6.11.1. Backlight.....	30
6.6.11.2. Display Flip.....	30
6.6.11.3. Key Lock.....	31
6.6.12. DMX Lost.....	31
6.6.13. Information.....	31
6.6.13.1. Power Consumption.....	32
6.6.14. Send Settings.....	32
6.6.15. Factory Settings.....	32
6.7. DMX Channels.....	33
6.7.1. DMX Channels Overview.....	33
6.7.2. Dimmer (1 Channel), Pixel (3 Channels), XY (8 Channels), Raw (14 Channels).....	34
6.7.3. Basic (8 Channels), RGB (12 Channels), CMY (12 Channels), HSI (10 Channels).....	36
6.7.4. HSI+CCT (12 Channels), CMY+CCT (15 Channels), RGB+CCT (15 Channels).....	38
6.7.5. Lee Color Presets.....	40
6.8. RDM Information.....	42
6.8.1. RDM Details.....	42
6.8.2. Supported RDM PIDs (Parameter IDs).....	42
7. Troubleshooting.....	43
8. Maintenance.....	44
8.1. Safety Instructions for Maintenance.....	44
8.2. Preventive Maintenance.....	44
8.2.1. Basic Cleaning Instructions.....	44
8.3. Corrective Maintenance.....	44
9. Deinstallation, Transportation and Storage.....	45
9.1. Instructions for Deinstallation.....	45
9.2. Instructions for Transportation.....	45
9.3. Storage.....	45
10. Disposal.....	45
11. Approval.....	45
12. Changelog.....	45

1. Introduction

1.1. Before Using the Product



Important

Read and follow the instructions in this user manual before installing, operating or servicing this product.

The manufacturer will not accept liability for any resulting damages caused by the non-observance of this manual.

After unpacking, check the contents of the box. If any parts are missing or damaged, contact your Highlite International dealer.

Your shipment includes:

- Infinity Raccoon P7/7
- Power Pro True cable (1,5 m)
- Quick-lock bracket
- User manual

Figure 1

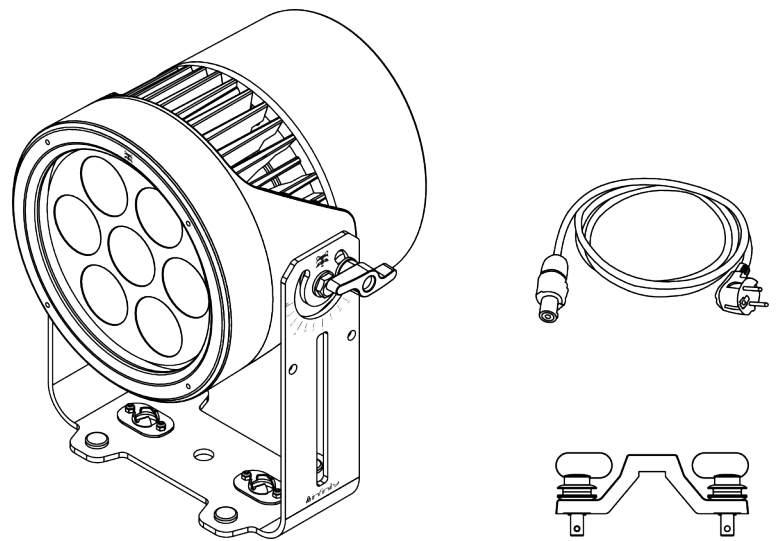

1.2. Intended Use

This device is intended for professional use as an LED luminaire for stage lighting. It can be installed indoors and outdoors. This device is not suitable for households and for general lighting.

Any other use, not mentioned under intended use, is regarded as non-intended and incorrect use.

1.3. LEDs Lifespan

The light output of the LEDs gradually decreases over time (lumen depreciation). High operating temperatures contribute to this process. You can extend the lifespan of the LEDs by providing adequate ventilation and operating the LEDs at the lowest possible brightness.

1.4. Text Conventions

Throughout the user manual the following text conventions are used:

- Buttons: All buttons are in bold lettering, for example "Press the **UP/DOWN** buttons"
- References: References to parts of the device are in bold lettering, for example: "turn the **adjustment handle (05)**". References to chapters are hyperlinked
- 0–255: Defines a range of values
- Notes: **Note:** (in bold lettering) is followed by useful information or tips

1.5. Symbols and Signal Words

Safety notes and warnings are indicated throughout the user manual by safety signs.

Always follow the instructions provided in this user manual.



DANGER

Indicates an imminently hazardous situation which, if not avoided, will result in death or serious injury.



WARNING

Indicates a potentially hazardous situation which, if not avoided, could result in death or serious injury.



CAUTION

Indicates a potentially hazardous situation, which, if not avoided, may result in minor or moderate injury.



Attention

Indicates important information for the correct operation and use of the product.



Important

Read and observe the instructions in this document.



Electrical hazard



Provides important information about the disposal of this product.

1.6. Symbols on the Information Label

This product is provided with an information label. The information label is located on the mounting bracket of the device.

The information label contains the following symbols:



This device shall not be treated as household waste.



Read and follow the instructions in the user manual before installing, operating or servicing the device.



This device falls under IEC protection class I.

IP65

This devices is rated IP65.

2. Safety



Important
Read and follow the instructions in this user manual before installing, operating or servicing this product.

The manufacturer will not accept liability for any resulting damages caused by the non-observance of this manual.

2.1. Warnings and Safety Instructions



DANGER
Danger for children

For adult use only. The device must be installed beyond the reach of children.

- Do not leave any parts of the packaging (plastic bags, polystyrene foam, nails, etc.) within the reach of children. Packaging material is a potential source of danger for children.



DANGER
Electric shock caused by dangerous voltage inside

There are areas inside the device where dangerous touch voltage may be present.

- Do not open the device or remove any covers.
- Do not operate the device if the covers or the housing are open. Before operation, check if the housing is firmly closed and all screws are tightly fastened.
- Disconnect the device from the electrical power supply before service and maintenance, and when the device is not in use.



DANGER
Electric shock caused by short-circuit

This device falls under IEC protection Class I.

- Make sure that the device is electrically connected to ground (earth). Connect the device only to a socket-outlet with a ground (earth) connection.
- Do not cover the ground (earth) connection.
- Do not bypass the thermostatic switch or fuses.
- Do not let the power cable come into contact with other cables. Handle the power cable and all connections with the mains with caution.
- Do not modify, bend, mechanically strain, put pressure on, pull or heat up the power cable.
- Make sure that the power cable is not crimped or damaged. Examine the power cable periodically for any defects.
- Do not immerse the device in water or other liquids. Do not install the device in a location where flooding may occur.
- Do not use the device during thunderstorms. Disconnect the device from the electrical power supply immediately.
- Keep the connectors sealed with the rubber caps when the connectors are not in use.
- Do not connect the cables from above the connectors, if the device is installed outdoors. Make a 'drip loop' in the cable so that rain water cannot enter the device.



WARNING
Risk of epileptic shock

Strobe lighting can trigger seizures in photosensitive epilepsy. Sensitive persons should avoid looking at strobe lights.



Attention
Power supply

- Before connecting the device to the power supply, make sure that the current, voltage and frequency match the input voltage, current and frequency specified on the information label on the device.
- Make sure that the cross-sectional area of the extension cords and power cables is sufficient for the required power consumption of the device.



Attention
General safety

- Do not connect the device to a dimmer pack.
- Do not switch the device on and off in short intervals. This reduces the device's life.
- Do not shake the device. Avoid brute force when installing or operating the device.
- Change the lens or the LEDs if they are visibly damaged to such an extent that their effectiveness is impaired, for example by cracks or deep scratches. Contact your Highlite International dealer for more information, as servicing can be performed only by instructed or skilled persons.
- If the device is dropped or struck, disconnect the device from the electrical power supply immediately.
- If the device is exposed to extreme temperature variations (e.g. after transportation), do not switch it on immediately. Let the device reach room temperature before switching it on, otherwise it may be damaged by the formed condensation.
- If the device fails to work properly, discontinue use immediately.



Attention
For professional use only
This device must be used only for the purposes it is designed for.

This device is intended for professional use as an LED luminaire for stage lighting. Any incorrect use may lead to hazardous situations and result in injuries and material damage.

- This device is not suitable for households and for general lighting.
- This device is not designed for permanent operation.
- This device does not contain user-serviceable parts. Unauthorized modifications to the device will render the warranty void. Such modifications may result in injuries and material damage.



Attention
Before each use, examine the device visually for any defects.

Make sure that:

- All screws used for installing the device or parts of the device are tightly fastened and are not corroded.
- The safety devices are not damaged.
- There are no deformations on housings, fixings and installation points.
- The lens is not cracked or damaged.
- The power cables are not damaged and do not show any material fatigue.

Attention

Do not expose the device to conditions that exceed the rated IP class conditions.

This device is IP65 rated. IP (Ingress Protection) 65 class means that the device is dust-tight and protected against harmful effect of water jets.

Keep the connectors sealed with the rubber caps when the connectors are not in use.

2.2. Requirements for the User

This product may be used by ordinary persons. Maintenance may be carried out by ordinary persons. Installation and service shall be carried out only by instructed or skilled persons. Contact your Highlite International dealer for more information.

Instructed persons have been instructed and trained by a skilled person, or are supervised by a skilled person, for specific tasks and work activities associated with the installation, service and maintenance of this product, so that they can identify risks and take precautions to avoid them.

Skilled persons have training or experience, which enables them to recognize risks and avoid hazards associated with the installation, service and maintenance of this product.

Ordinary persons are all persons other than instructed persons and skilled persons. Ordinary persons include not only users of the product but also any other persons that may have access to the device or who may be in the vicinity of the device.

2.3. Personal Protective Equipment

During installation, deinstallation and rigging wear personal protective equipment in compliance with the national and site-specific regulations.

3. Description of the Device

The Infinity Raccoon P7/7 is an IP65-rated, high-CRI, LED par effect, suitable for indoor and outdoor applications. The device is equipped with 7 LEDs that have 7 colors each: Red, Green, Blue, Lime, Amber, Cyan, and Royal Blue. You can switch between maximum brightness and maximum light quality (high CRI) mode. The calibrated XY color engine guarantees stable color output at every temperature of the LEDs and every brightness setting, without any visible color shift when dimming.

3.1. Front view

Figure 2

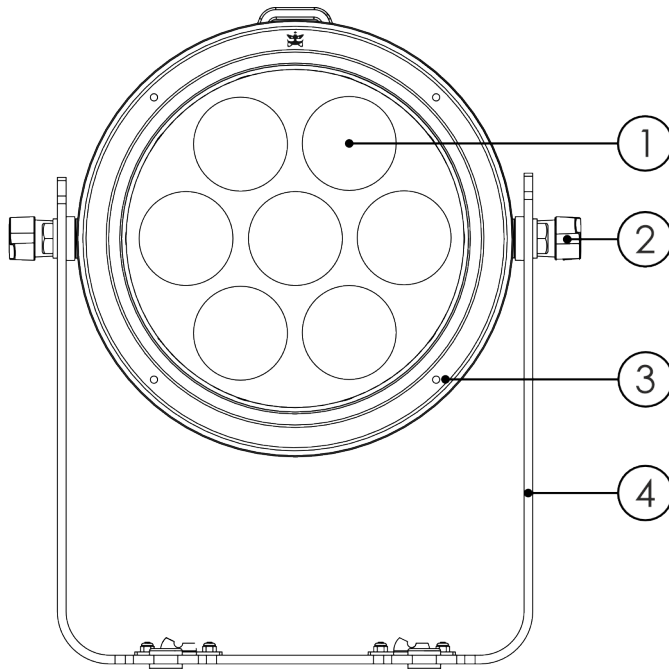

- 01) 7 x 25 W RGBCALDB LEDs
- 02) 2 x adjustment screws
- 03) 4 x openings for screws
- 04) Mounting bracket

3.2. Back View

Figure 3

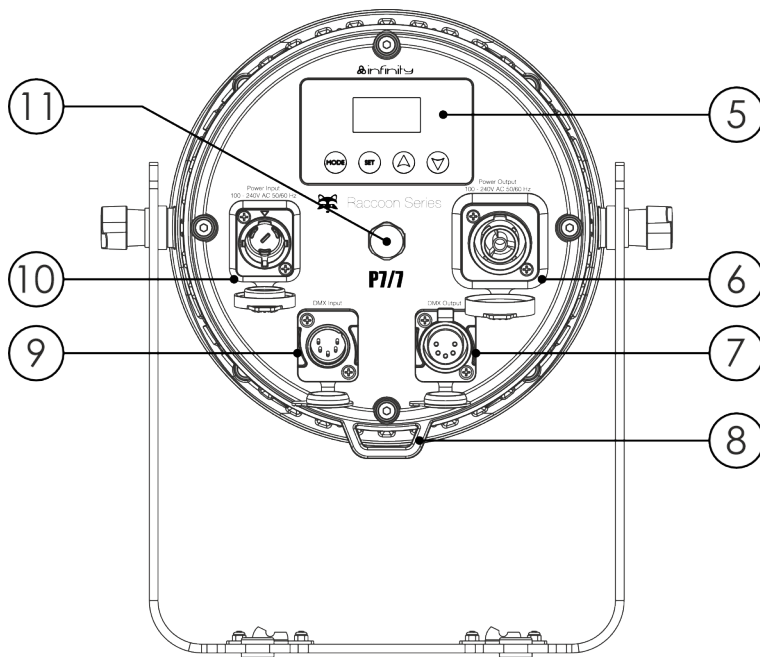

- 05) Control panel: OLED display and control buttons
- 06) IP65-rated Seetronic power connector OUT
- 07) IP65-rated Seetronic 5-pin DMX signal connector OUT
- 08) Safety eye
- 09) IP65-rated Seetronic 5-pin DMX signal connector IN
- 10) IP65-rated Seetronic power connector IN
- 11) Protective vent

3.3. Product Specifications

Model:	Raccoon P7/7
Source:	
Light source type	LED
Light source quantity	7
Light source power	25 W
LED color type	RGBCALDB
Luminous flux (total)	4932 lm
CRI	95
Minimum CCT	2000 K
Maximum CCT	8000 K
Optical:	
Beam angle (circular)	15°
Control and Programming:	
Control mode	DMX / Manual / Static Dimmer
DMX channels	1 / 3 / 8 / 8 / 10 / 12 / 12 / 12 / 14 / 15 / 15
Protocols	DMX / RDM
Display	OLED
Dynamic Effects:	
Dimmer	0–100 %
Strobe	0–20 Hz
Electrical Specifications and Connections:	
Power supply	100–240 V AC 50/60 Hz
Power consumption	150 W
Power connector IN	Power Pro True
Power connector OUT	Power Pro True
DMX connector IN	XLR 5P
DMX connector OUT	XLR 5P
Mechanical Specifications:	
Length	203 mm
Width	262 mm
Height	301 mm
Weight	6 kg
IP rating	IP65
Housing	Aluminum die-cast
Color	Black
Product Properties:	
Cooling	Convection
Thermal Specifications:	
Maximum ambient temperature	45 °C
Minimum operating temperature	-20 °C

Included Items:

Included cables

Power Pro True cable

Included rigging

Quick-lock bracket

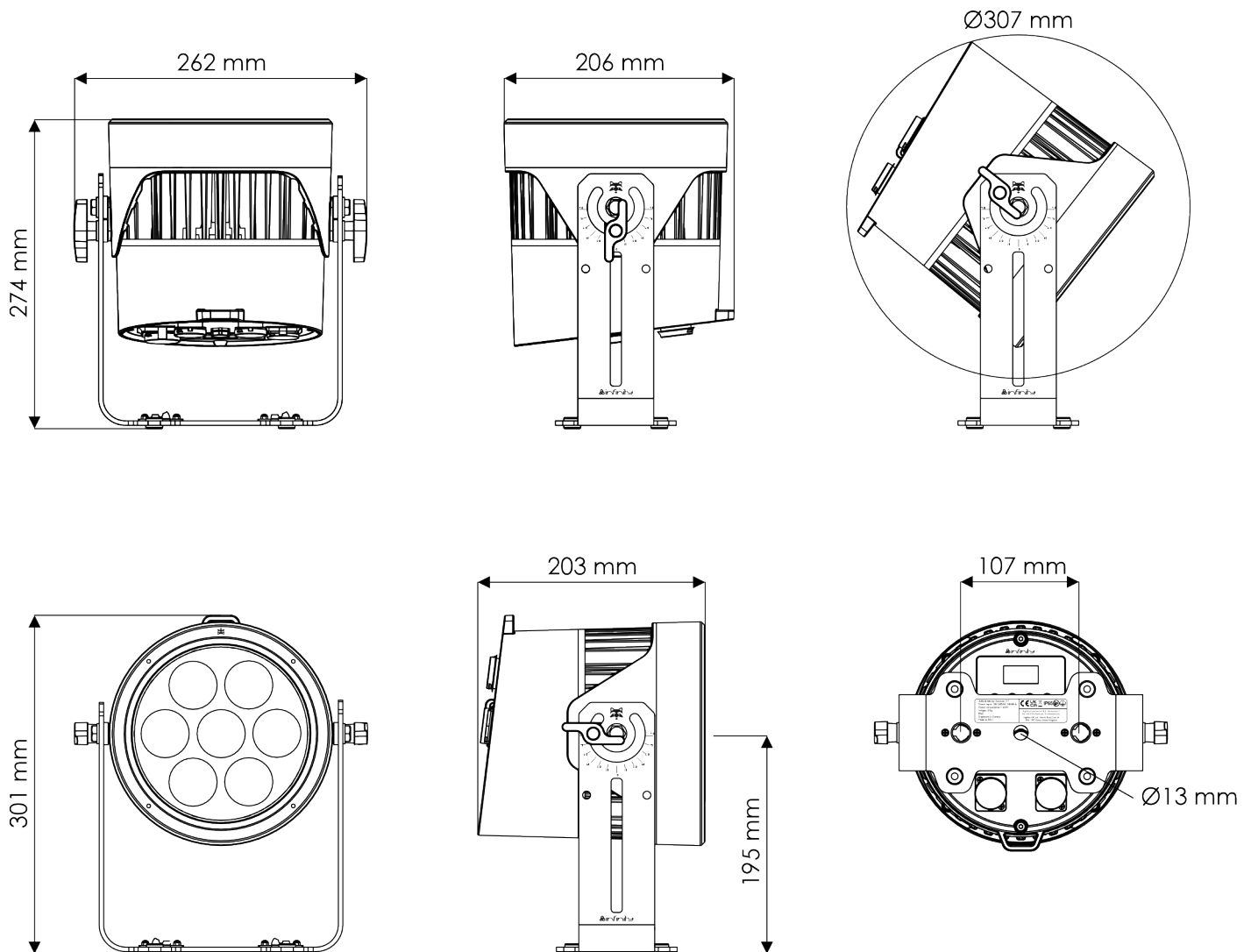
3.4. Dimensions
Figure 4

3.5. Optional Accessories

The following optional accessories are available for this product:

- [200251](#) Barndoor for 300W Fresnel
- [200560](#) Accessory Holder for Raccoon Series
- [200561](#) Top Hat for Raccoon Series
- [200562](#) Dual Accessory holder for Raccoon Series
- [200564](#) 15° Diffuser for Raccoon Series
- [200565](#) 20° Diffuser for Raccoon Series
- [200566](#) 40° Diffuser for Raccoon Series
- [200567](#) 90° Diffuser for Raccoon Series
- [200568](#) 15° x 60° Diffuser for Raccoon Series
- [D7498B](#) LCA-SPE1 Case for 8x Spectral M800

Contact your Highlite International dealer for more information.

4. Installation

4.1. Safety Instructions for Installation



WARNING

Incorrect installation can cause serious injuries and damage of property.

If trussing systems are used, installation must be carried out only by instructed or skilled persons.

Follow all applicable European, national and local safety regulations concerning rigging and trussing.

4.2. Personal Protective Equipment

During installation, deinstallation and rigging wear personal protective equipment in compliance with the national and site-specific regulations.

4.3. Installation Site Requirements

- The device can be used indoors and outdoors.
- The device must be installed away from heating sources and direct sunlight.
- The ambient temperature must be in the range -20 and 45 °C.

4.4. Rigging

The device can be positioned on a flat surface or mounted to a truss or other rigging structure in any orientation. Make sure that all loads are within the pre-determined limits of the supporting structure.



CAUTION

Restrict the access under the work area during rigging/derigging.

To mount the device, follow the steps below:

- 01) Fasten the quick-lock bracket, supplied with the device, on the **mounting bracket (04)**.
- 02) Install the clamp. Make sure that you use a clamp suitable for attaching the device to a truss.

Figure 5

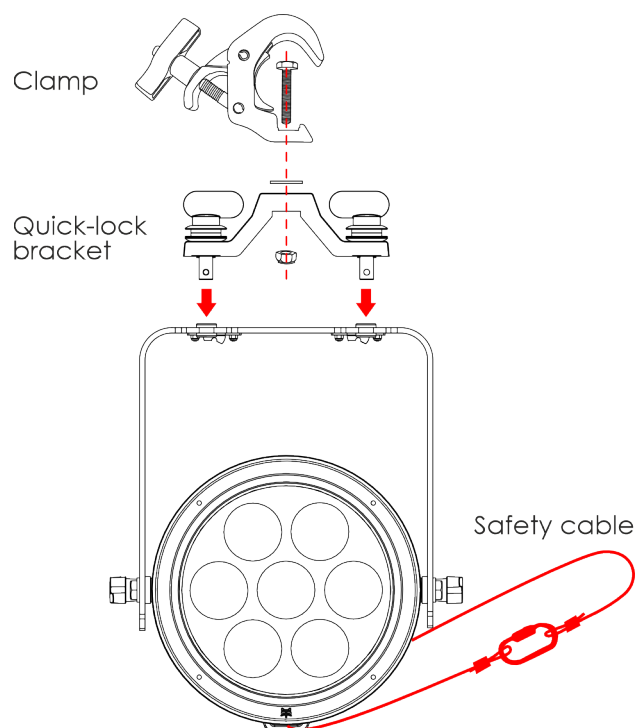

- 03) Attach the device to the supporting structure. Make sure that the device cannot move freely.
- 04) Secure the device with a secondary suspension, for example a safety cable. Make sure that the secondary suspension can hold 10 times the weight of the device. If possible, the secondary suspension should be attached to a supporting structure independent of the primary suspension. Put the safety cable through the **safety eye (08)**.

4.5. Angle Adjustment

You can adjust the angle of the device with the 2 **adjustment screws (02)**.

- 01) Turn the 2 **adjustment screws (02)** counterclockwise to loosen them.
- 02) Tilt the device to the desired angle. The tilt angles are marked on the **mounting bracket (04)**.
- 03) Turn the 2 **adjustment screws (02)** clockwise to tighten them. Make sure that the device cannot move freely after the 2 **adjustment screws (02)** are tightened.

Figure 6

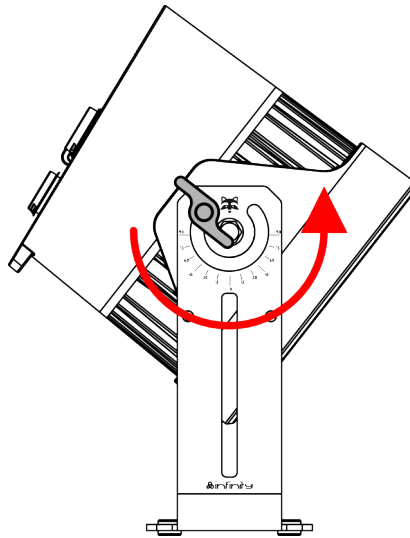

4.6. Installation of Accessories

There are a number of accessories available for the device (see [3.5. Optional Accessories](#) on page 11). You need to install an accessory holder before you can attach an accessory to the device.

There are 2 accessory holders available: single accessory holder (product code: [200560](#)) and dual accessory holder (product code: [200562](#)).

- Use the single accessory holder to attach a barndoor or a top hat
- Use the dual accessory holder to attach a barndoor or top hat together with a diffuser

If you want to attach only a diffuser, it is not necessary to install first an accessory holder.

The accessories are not supplied with the device. Contact your Highlite International dealer for more information.

4.6.1. Accessory Holder Installation

To install an accessory holder, follow the steps below:

- 01) Put the accessory holder against the lens of the device and align the openings for the screws on the accessory holder with the 4 **openings for screws (03)** on the device.
- 02) Use a screwdriver to tighten the 4 screws, supplied with the accessory holder.
- 03) Secure the accessory holder to the overhead structure with a secondary attachment, for example a safety cable.

Note:

This figure shows the installation of the single accessory holder (product code: [200560](#)).

Figure 7

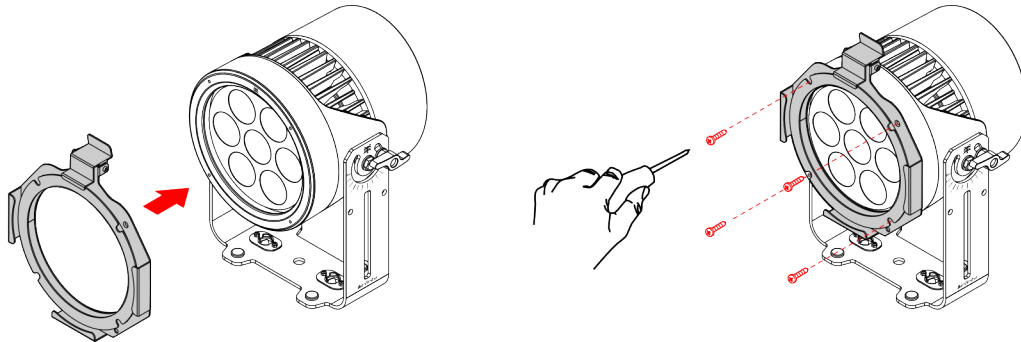

4.6.2. Barndoor Installation

To install the barndoor, follow the steps below:

- 01) Install one of the accessory holders (see [4.6.1. Accessory Holder Installation](#) on page 14).
- 02) Lift the spring-loaded retainer clip on the accessory holder and flip it backwards.
- 03) Insert the barndoor into the accessory holder.
- 04) Pull the spring-loaded retainer clip of the accessory holder downwards. The barndoor is locked in position.
- 05) Secure the barndoor to the overhead structure with a secondary attachment, for example a safety cable.

Figure 8

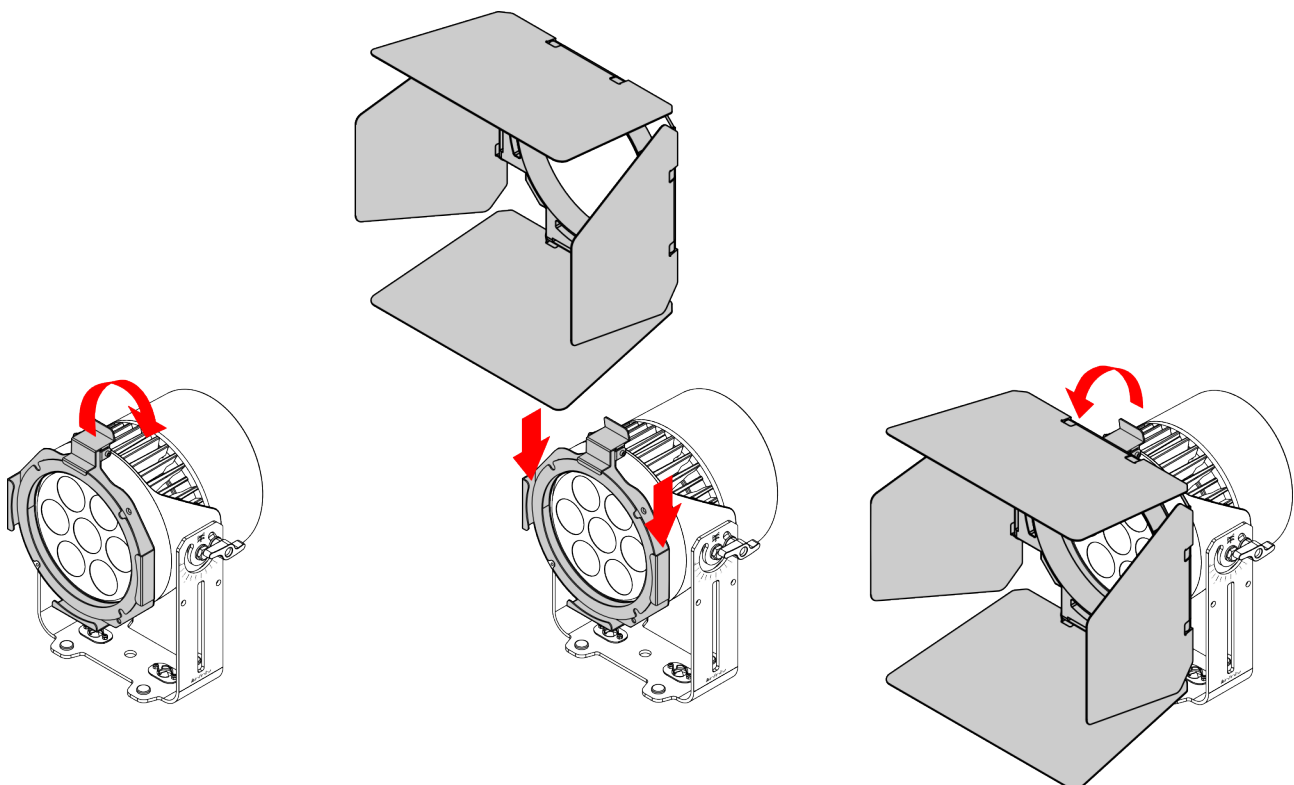

4.6.3. Top Hat Installation

To install the top hat, follow the steps below:

- 01) Install one of the accessory holders (see [4.6.1. Accessory Holder Installation](#) on page 14).
- 02) Lift the spring-loaded retainer clip on the accessory holder and flip it backwards.
- 03) Insert the top hat into the accessory holder.
- 04) Pull the spring-loaded retainer clip of the accessory holder downwards. The top hat is locked in position.
- 05) Secure the top hat to the overhead structure with a secondary attachment, for example a safety cable.

Figure 9

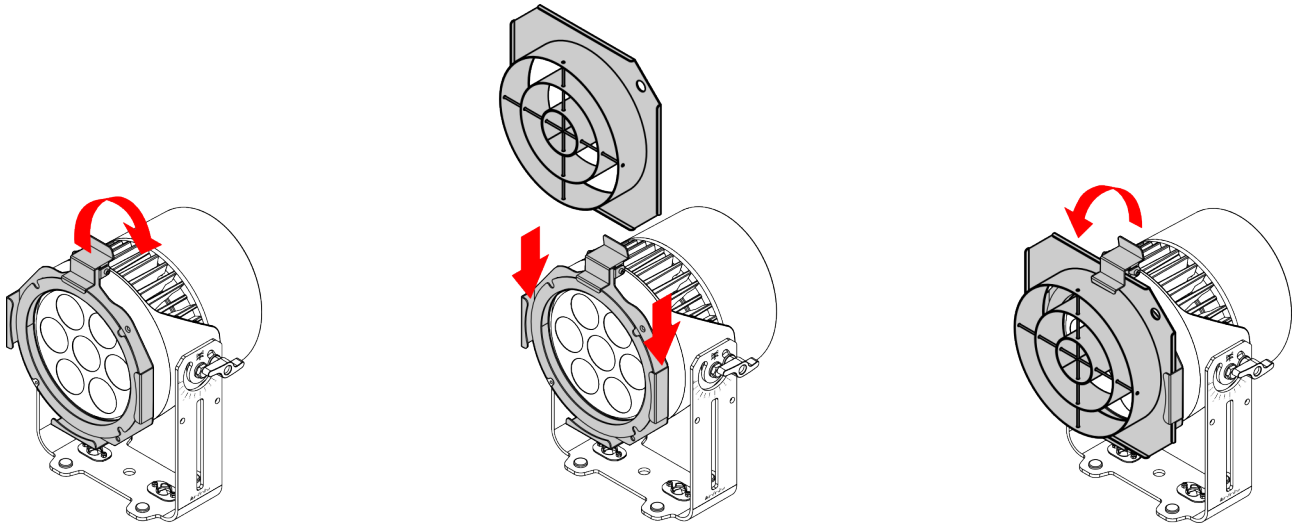

4.6.4. Diffuser Installation

To install the diffuser, follow the steps below:

- 01) Install the dual accessory holder (see [4.6.1. Accessory Holder Installation](#) on page 14). This step is optional. Do this step only if you want to use the diffuser together with a barndoor or a top hat.
- 02) Put the diffuser on the lens of the device or on the opening of the dual accessory holder, if installed. The magnet of the diffuser will hold the diffuser in position.
- 03) Secure the diffuser to the overhead structure with the safety cable supplied with the diffuser.

Note:

This figure shows installation of the diffuser without the dual accessory holder.

Figure 10

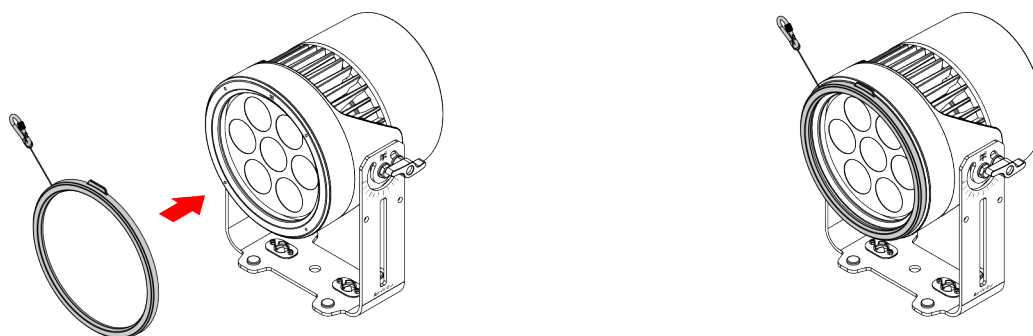

4.7. Connecting to Power Supply



DANGER
Electric shock caused by short-circuit

The device accepts AC mains power at 100–240 V and 50/60 Hz. Do not supply power at any other voltage or frequency to the device.

This device falls under IEC protection class I. Make sure that the device is always electrically connected to the ground (earth).

Before connecting the device to the socket-outlet:

- Make sure that the power supply matches the input voltage specified on the information label on the device.
- Make sure that the socket-outlet has a ground (earth) connection.

Connect the device to the socket-outlet with the power plug. Do not connect the device to a dimmer circuit, as this may damage the device.

This device is IP65 rated.

- Do not expose the device to conditions that exceed the rated IP class conditions.
- Keep the connectors sealed with the rubber caps when the connectors are not in use.
- Do not connect the cables from above the connectors, if the device is installed outdoors. Make a 'drip loop' in the cable so that rain water cannot enter the device.
- Make sure that the cable run is not too heavy. A heavy cable run can cause damage to the connectors. If the connectors are damaged, their ingress protection (IP) can deteriorate.

4.8. Power Linking of Multiple Devices

This device supports power linking. Power can be relayed to another device via the power OUT connector. Note that the input and the output connectors have different designs: one type cannot be connected to the other.

Power linking of multiple devices must be carried out only by instructed or skilled persons.



WARNING
Incorrect power linking may lead to overload of the electrical circuit and result in serious injuries and damage of property.

To prevent overload of the electrical circuit, when power linking multiple devices:

- Use cables with sufficient current-carrying capacity. The power cable supplied with the device is not suitable for power linking of multiple devices.
- Make sure that the total current draw of the device and all connected devices does not exceed the rated capacity of the power cables and the circuit breaker.
- Do not link more devices on one power link than the maximum recommended number.

Maximum recommended number of devices:

- at 100–120 V: 3 devices Raccoon P7/7
- at 200–240 V: 6 devices Raccoon P7/7

5. Setup

5.1. Warnings and Precautions



DANGER
Electric shock caused by short-circuit

This device is IP65 rated.

- Do not expose the device to conditions that exceed the rated IP class conditions.
- Keep the connectors sealed with the rubber caps when the connectors are not in use.
- Do not connect the cables from above the connectors, if the device is installed outdoors. Make a 'drip loop' in the cable so that rain water cannot enter the device.
- Make sure that the cable run is not too heavy. A heavy cable run can cause damage to the connectors. If the connectors are damaged, their ingress protection (IP) can deteriorate.



Attention
Connect all data cables before supplying power.
Disconnect power supply before connecting or disconnecting data cables.

5.2. Stand-alone Setup

When the Raccoon P7/7 is not connected to a controller or to other devices, it functions as a stand-alone device. It can be operated manually via the control panel or in auto mode.

For more information refer to Control Modes (see [6.2. Control Modes](#) on page 20).

5.3. DMX Connection

5.3.1. DMX-512 Protocol

You need a DMX serial data link to run light shows of one or more devices using a DMX-512 controller.

The Raccoon P7/7 has 5-pin DMX signal IN and OUT connectors.

The pin assignment is as follows: pin 1 (ground), pin 2 (-), pin 3 (+), pin 4 (N/C), pin 5 (N/C).

Devices on a serial data link must be daisy-chained in a single line. The number of devices that you can control on one data link is limited by the combined number of the DMX channels of the connected devices and the 512 channels available in one DMX universe.

To comply with the TIA-485 standard, no more than 32 devices should be connected on one data link. In order to connect more than 32 devices on one data link, you must use a DMX optically isolated splitter/booster, otherwise this may result in deterioration of the DMX signal.

Note:

- Maximum recommended DMX data link distance: 300 m
- Maximum recommended number of devices on a DMX data link: 32 devices

5.3.2. DMX Cables

Shielded twisted-pair cables with 5-pin XLR connectors must be used for reliable DMX connection. You can purchase DMX cables directly from your Highlite International dealer or make your own cables.

If you use XLR audio cables for DMX data transmission, this may lead to signal degradation and unreliable operation of the DMX network.

When you make your own DMX cables, make sure that you connect the pins and wires correctly as shown in the figure below.

Figure 11

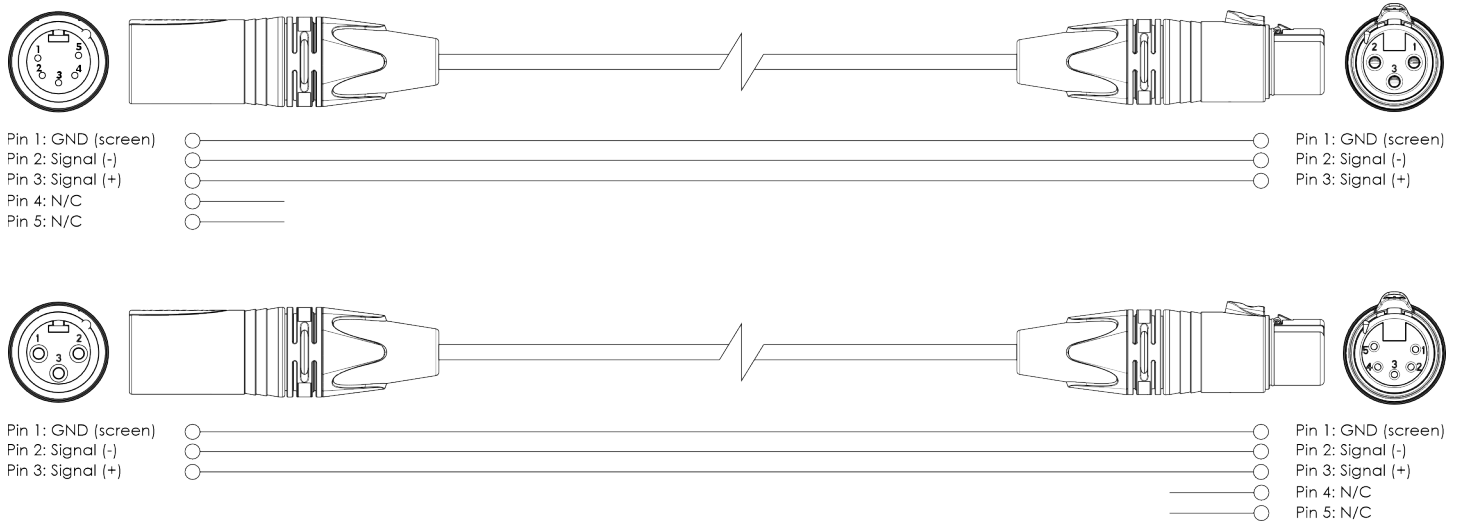

5.3.3. DMX Linking

To connect multiple devices on one DMX data link, follow the steps below:

- 01) Use a 5-pin DMX cable to connect the DMX OUT connector of the lighting controller to the DMX IN connector of the 1st device.
- 02) Connect the DMX OUT connector of the 1st device to the DMX IN connector of the 2nd device with a 5-pin DMX cable.
- 03) Repeat step 2 to connect all devices in a daisy-chain.
- 04) Connect a DMX terminator (120 Ω resistor) to the DMX OUT connector of the last device on the data link.

Figure 12

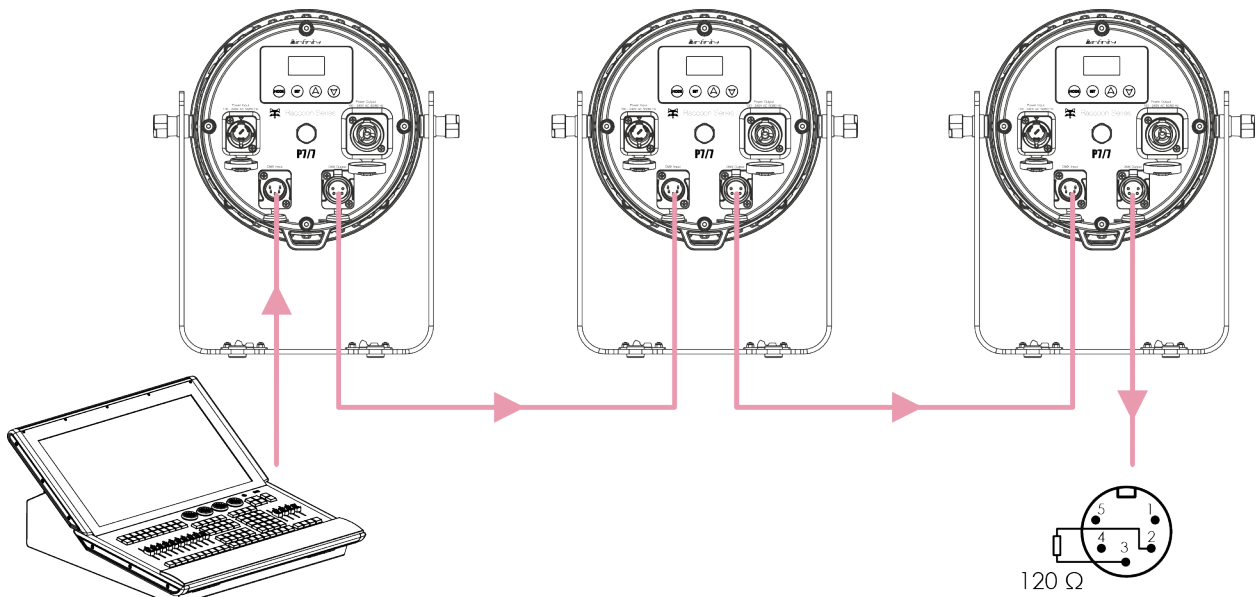

5.3.4. DMX Addressing

In a setup with multiple devices, make sure that you set the DMX starting address of each device correctly. The Raccoon P7/7 has 11 personalities:

- Dimmer (1 channel)
- Pixel (3 channels)
- Basic (8 channels)
- XY (8 channels)
- RGB (12 channels)
- CMY (12 channels)
- HSI (10 channels)
- HSI+CCT (12 channels)
- CMY+CCT (15 channels)
- RGB+CCT (15 channels), and
- Raw (14 channels).

If you want to connect multiple devices on one data link and use them in 14-channel mode (Raw), follow the steps below:

- 01) Set the starting address of the 1st device on the data link to 1 (001).
- 02) Set the starting address of the 2nd device on the data link to 15 (015), as $1 + 14 = 15$.
- 03) Set the starting address of the 3rd device on the data link to 29 (029), as $15 + 14 = 29$.
- 04) Continue assigning the starting addresses of the remaining devices by adding each time 14 to the previous number.

Make sure that you do not have any overlapping channels in order to control each Raccoon P7/7 correctly. If two or more devices are addressed similarly, they will work similarly.

6. Operation

6.1. Safety Instructions for Operation



Attention

This device must be used only for the purposes it is designed for.

This device is intended for professional use as an LED luminaire for stage lighting. It can be installed indoors and outdoors. This device is not suitable for households and for general lighting.

Any other use, not mentioned under intended use, is regarded as non-intended and incorrect use.



Attention

Power supply

Before connecting the device to the power supply, make sure that the current, voltage and frequency match the input voltage, current and frequency specified on the information label on the device.

6.2. Control Modes

The Raccoon P7/7 can be operated with a DMX controller or as a stand-alone device.

The Raccoon P7/7 supports the following control modes:

- Stand-alone: Manual operation, auto operation mode (built-in programs, color presets)
- DMX-512: Dimmer (1 channel), Pixel (3 channels), Basic (8 channels), XY (8 channels), RGB (12 channels), CMY (12 channels), HSI (10 channels), HSI+CCT (12 channels), CMY+CCT (15 channels), RGB+CCT (15 channels), Raw (14 channels)

For more information about how to connect the devices, refer to Setup (see [5. Setup](#) on page 17).

To operate the device as a stand-alone device:

- Adjust the dimmer values, select a preset color, adjust the color temperature and the tint of the white point, or create a custom color in the Static Color submenu (see [6.6.3.1. Static Color Mode](#) on page 26)
- Select one of the 3 built-in effects (see [6.6.3.2. Built-in Effects](#) on page 26) in Manual mode and adjust the parameters of the selected built-in effect

To operate the device with a DMX controller:

- 01) Select the DMX channel mode in the DMX Mode menu (see [6.6.1. DMX Mode](#) on page 25). Refer to the DMX chart (see [6.7. DMX Channels](#) on page 33) for a complete overview of all DMX channels.
- 02) Set the DMX starting address (see [5.3.4. DMX Addressing](#) on page 19) of the device in DMX Address menu (see [6.6.2. DMX Address](#) on page 25).
- 03) Set the behavior of the device in case there is no DMX signal in the DMX Lost menu (see [6.6.12. DMX Lost](#) on page 31).

6.3. Control Panel

Figure 13

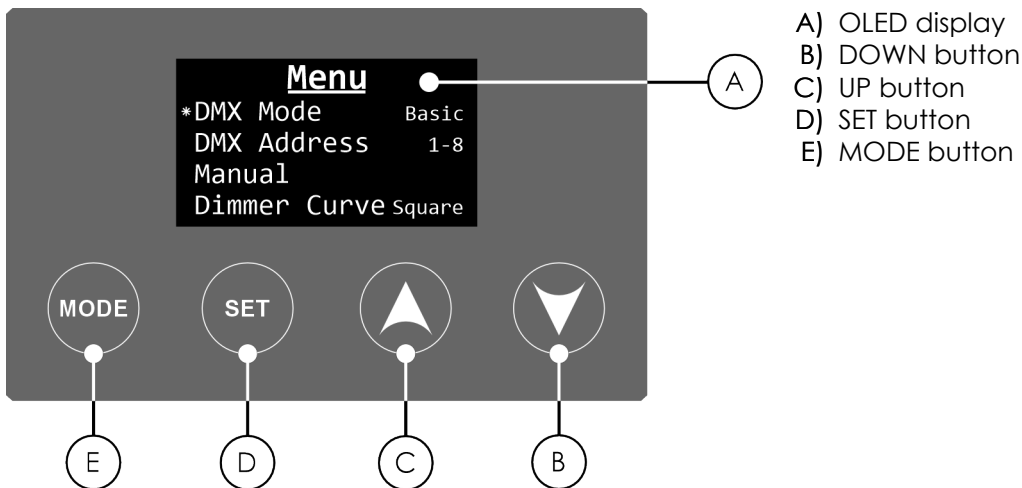

- Use the **MODE** button to exit the current submenu, to return to the Main Menu and to navigate through the Main Menu.
- Use the **UP/DOWN** buttons to navigate through the menus or to increase/decrease numeric values.
- Use the **SET** button to open the desired menu, to confirm your choice or to set the currently selected value.

6.4. Start-up

Upon start-up, the display shows a splash screen with the Infinity logo and the name of the device.



Immediately afterwards, the display shows the start screen. The start screen provides information about the current control mode of the device, the behavior of the device in case there is no DMX signal, the PWM frequency and the temperature of the LEDs.



Press any button to enter the main menu.

Note:

If no button is pressed, after 20 s the display returns to the start screen. After 5 s more the backlight of the display turns off. If the DMX signal is lost, the display is blinking. You can change this setting in the Backlight submenu (see [6.6.11.1. Backlight](#) on page 30).

6.5. Menu Overview

Level 1	Level 2	Level 3	Level 4	Level 5	Default Setting
DMX Mode (see 6.6.1. DMX Mode on page 25)	Dimmer (1)				Dimmer (1)
	Pixel (3)				
	Basic (8)				
	XY (8)				
	RGB (12)				
	CMY (12)				
	HSI (10)				
	HSI+CCT (12)				
	CMY+CCT (15)				
	RGB+CCT (15)				
	Raw (14)				
DMX Address (see 6.6.2. DMX Address on page 25)	000–512				1
Manual (see 6.6.3. Manual Mode on page 26)	Static	Dimmer	0,0–100,0 %		100,0 %
		White Point	Temperature	2000 K	3200 K
				2200 K	
				2400 K	
				2600 K	
				2800 K	
				3000 K	
				3200 K	
				3600 K	
				4200 K	
				5600 K	
	6500 K				
	8000 K				
		Tint	-100,0 to 100,0 %		0,0 %
	Preset Color	OPEN			OPEN
		Lxxx (see 6.7.5. Lee Color Presets on page 40)			
		Raw Color	Red	0–255	0
			Green	0–255	0
			Blue	0–255	0
			Lime	0–255	0
Amber			0–255	0	
Cyan			0–255	0	
Royal Blue	0–255		0		
Effect 1	Dimmer	0,0–100,0 %		100,0 %	
	Period	2,0–60,0 s		30,0 s	
	Fade in	0–100 %		100 %	
	Fade out	0–100 %		100 %	
Effect 2	Dimmer	0,0–100,0 %		100,0 %	
	Period	2,0–60,0 s		30,0 s	
	Fade in	0–100 %		100 %	
	Fade out	0–100 %		100 %	

Level 1	Level 2	Level 3	Level 4	Level 5	Default Setting	
	Effect 3	Dimmer	0,0–100,0 %		100,0 %	
		Period	2,0–60,0 s		30,0 s	
		Fade in	0–100 %		100 %	
		Fade out	0–100 %		100 %	
Dimmer Curve (see 6.6.4. Dimmer Curve on page 27)	Linear				Square	
	S-Curve					
	Square					
	Inverse Square					
Dimmer Speed (see 6.6.5. Dimmer Speed on page 27)	Auto				Auto	
	Fast					
	Medium					
	Slow					
Color Space (see 6.6.6. Color Space on page 28)	Native				Native	
	sRGB					
	Rec. 2020					
	ProPhoto RGB					
Tungsten (see 6.6.7. Tungsten on page 29)	Off				Off	
	575/750 W					
	1000 W					
	2000 W					
LED Mode (see 6.6.8. LED Mode on page 29)	High Quality				High Quality	
	High Brightness					
Calibration (see 6.6.9. Calibration on page 30)	Off				On	
	On					
LED Frequency (see 6.6.10. LED Frequency on page 30)	640 Hz				1280 Hz	
	1280 Hz					
	2500 Hz					
	5 kHz					
	10 kHz					
	25 kHz					
Display (see 6.6.11. Display on page 30)	Backlight	Auto			Auto	
		Stay On				
		Stay Off				
	Display Flip	Regular				Regular
		Top Down				
	Key Lock	Locked				Unlocked
Unlocked						
DMX Lost (see 6.6.12. DMX Lost on page 31)	Blackout				Hold	
	Hold					
	Manual					
Information (see 6.6.13. Information on page 31)	Operating Hours	0–100000:00 h				
	Source Hours	0–100000:00 h				
	Power Cycles	1–100000				
	Power	0–1000 W				

Level 1	Level 2	Level 3	Level 4	Level 5	Default Setting
	LED Temperature	0,0–99,0 °C			
	RDM ID				
	Product				
	Device Label				
	Version	Version Hash			
Send Settings (see 6.6.14. Send Settings on page 32)	Abort				
	Without DMX Addr				Abort
	With DMX Address				
Factory Settings (see 6.6.15. Factory Settings on page 32)	Abort				Abort
	Reset Settings				

6.6. Main Menu Options

The main menu has the following 15 options:

Menu	
*DMX Mode	Basic
DMX Address	1-8
Manual	
Dimmer Curve	Square
Dimmer Speed	Fast
Color Space	ProPhoto
Tungsten	Off
LED Mode	Quality
Calibration	On
LED Frequency	
Display	
DMX Lost	Hold
Information	
Send Settings	
Factory Settings	

DMX Mode
 DMX Address
 Manual
 Dimmer Curve
 Dimmer Speed
 Color Space
 Tungsten
 LED Mode
 Calibration
 LED Frequency
 Display
 DMX Lost
 Information
 Send Settings
 Factory Settings

- 01) Press the **UP/DOWN** buttons to navigate through the main menu.
- 02) Press the **SET** button to open the submenus.

6.6.1. DMX Mode

In this menu you can select the DMX channel mode.

01) Press the **UP/DOWN** buttons to select the desired DMX channel mode. There are 11 options:

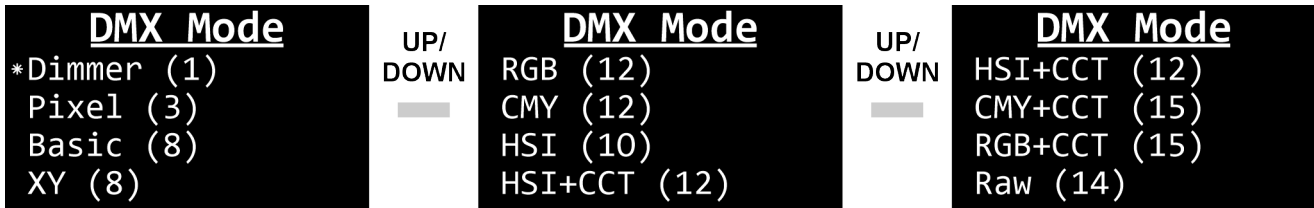

- Dimmer (1): 1 channel
- Pixel (3): 3 channels
- Basic (8): 8 channels
- XY (8): 8 channels
- RGB (12): 12 channels
- CMY (12): 12 channels
- HSI (10): 10 channels
- HSI+CCT (12): 12 channels
- CMY+CCT (15): 15 channels
- RGB+CCT (15): 15 channels
- Raw (14): 14 channels

02) Press the **SET** button to confirm the selection. For more information refer to the DMX chart (see [6.7. DMX Channels](#) on page 33).

6.6.2. DMX Address

In this menu you can set the DMX starting address of the device.

01) Press the **UP/DOWN** buttons to select the DMX starting address of the device. The selection range depends on the active DMX channel mode.

- Dimmer: 001–512 (1 channel)
- Pixel: 001–510 (3 channels)
- Basic: 001–505 (8 channels)
- XY: 001–505 (8 channels)
- RGB: 001–501 (12 channels)
- CMY: 001–501 (12 channels)
- HSI: 001–503 (10 channels)
- HSI+CCT: 001–501 (12 channels)
- CMY+CCT: 001–498 (15 channels)
- RGB+CCT: 001–498 (15 channels)
- Raw: 001–499 (14 channels)

02) Press the **SET** button to confirm.

Note:

The display shows the DMX address range of the device. For example, "2–13" means that the DMX starting address of the device is 002 and the device is operating in a 12-channel mode. The DMX address range of the device is 002–013.

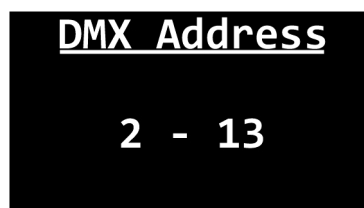

6.6.3. Manual Mode

In this menu you can use the device in Static Color mode or activate one of the 3 built-in effects.

01) Press the **UP/DOWN** buttons to select one of the 4 options:

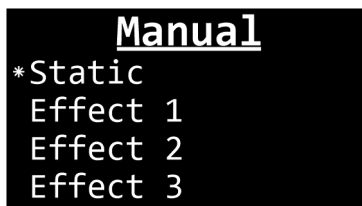

- Static (see [6.6.3.1. Static Color Mode](#))
- Effect 1, 2, 3 (see [6.6.3.2. Built-in Effects](#))

02) Press the **SET** button to confirm the selection.

6.6.3.1. Static Color Mode

In this submenu you can manually adjust the dimmer values, select a preset color, or adjust the color temperature and the tint.

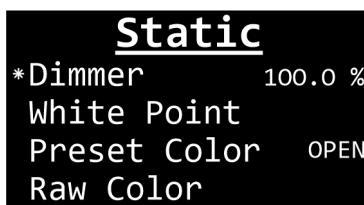

01) Press the **UP/DOWN** buttons to select one of the 4 submenus:

- Dimmer: Adjust the light output from low to high intensity (0,0–100,0 %, at steps of 0,1 %)
- White Point: Select the color temperature (2000 K, 2200 K, 2400 K, 2600 K, 2800 K, 3000 K, 3200 K, 3600 K, 4200 K, 5600 K, 6500 K, 8000 K) and the tint (from -100,0 to +100,0 %, at steps of 0,1 %)
- Preset Color: Select one of the Lee Color Presets (see [6.7.5. Lee Color Presets](#) on page 40) or no color preset (OPEN)
- Raw Color: Set the intensity of the LEDs for each color (Red, Green, Blue, Lime, Amber, Cyan, Royal Blue), from low to high intensity (0–255)

02) Press the **SET** button to confirm the selection.

6.6.3.2. Built-in Effects

01) Press the **UP/DOWN** buttons to select Effect 1, Effect 2 or Effect 3 to run the built-in effect. This opens a submenu where you can adjust the parameters of the selected built-in effect:

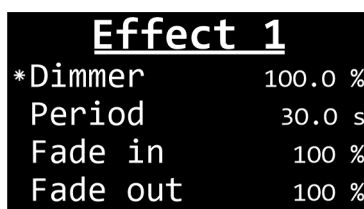

- Dimmer: Adjust the light output from low to high intensity (0,0–100,0 %, at steps of 0,1 %)
- Period: Set a timer for the duration of the effect (2,0–60,0 s, at steps of 0,1 s)
- Fade in: Select the fade-in speed from fast to slow (0–100 %, at steps of 1 %)
- Fade out: Select the fade-out speed from fast to slow (0–100 %, at steps of 1 %)

02) Press the **SET** button to confirm the value.

6.6.4. Dimmer Curve

In this menu you can select the dimming curve.

01) Press the **UP/DOWN** buttons to select one of the 4 options:

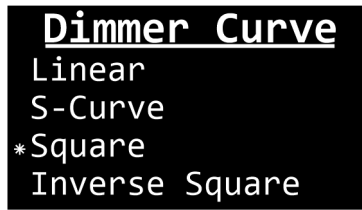

- Linear
- S-Curve
- Square
- Inverse Square

Figure 14

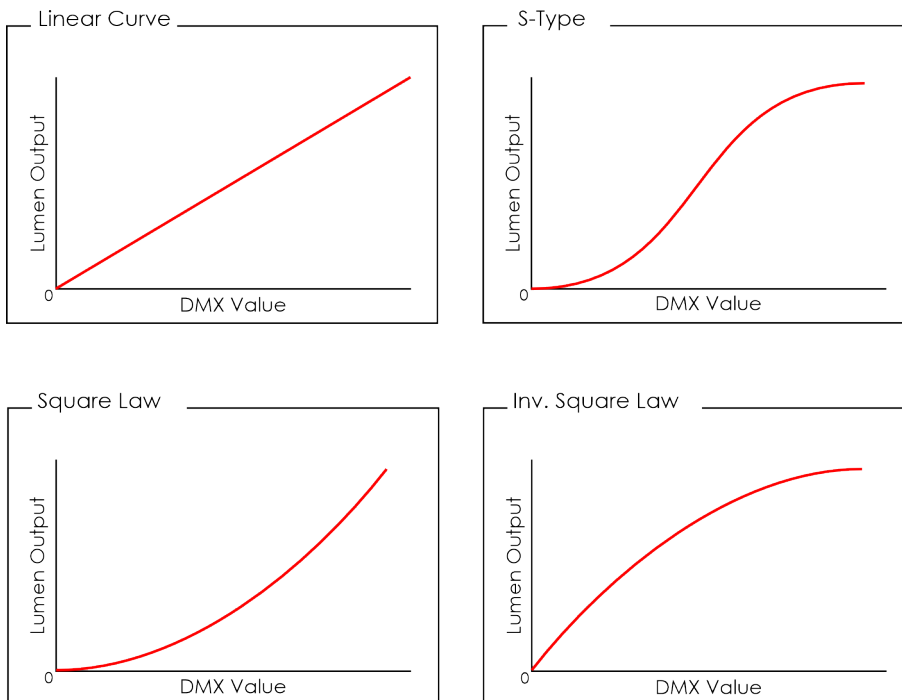

02) Press the **SET** button to confirm the selection.

6.6.5. Dimmer Speed

In this menu you can set the dimmer speed.

01) Press the **UP/DOWN** buttons to choose one of the 4 options:

- Auto: Fast dimmer with jump detection
- Fast: Fast dimmer
- Medium: Medium dimmer
- Slow: Slow dimmer

02) Press the **SET** button to confirm the selection.

6.6.6. Color Space

In this menu you can define the color space.

01) Press the **UP/DOWN** buttons to select one of the 5 options:

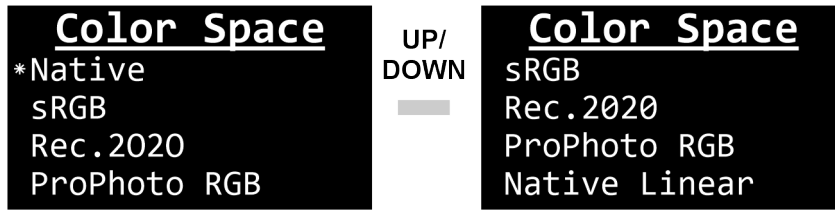

- Native
- sRGB
- Rec. 2020
- ProPhoto RGB
- Native Linear

02) Press the **SET** button to confirm the selection.

Notes:

- The Native color space is the complete subset of colors that can be created with individual LEDs installed in the device.
- The sRGB, Rec. 2020, and ProPhoto RGB allow you to select colors from the respective subset. If the selected color is not in the subset, the software creates a close match. It means that the color created by the software may differ from the originally selected color.
- The Native Linear color space always interpolates to D65 white point if the values are identical across RGB (i.e. 50 % RGB = D65). The Native color space does this within the virtual RGB emitters in the Native color space.

To avoid color differences, make sure that all devices in your setup use the same color space.

This figure shows a comparison of the color spaces in a CIE 1931 xy chromaticity diagram.

Figure 15

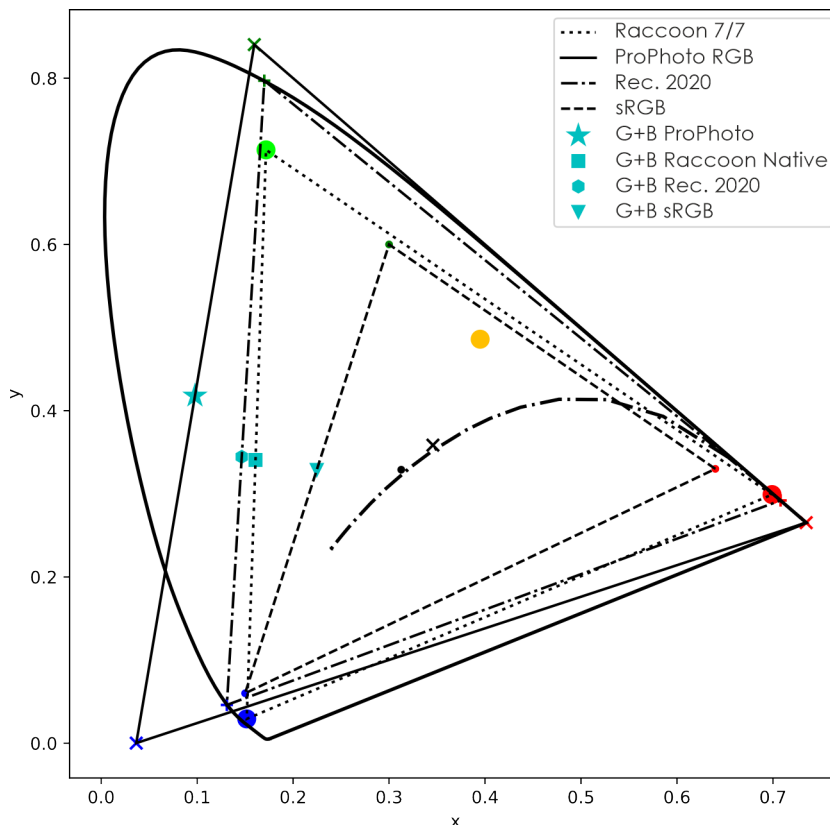

6.6.7. Tungsten

In this menu you can select Tungsten simulation at different outputs.

01) Press the **UP/DOWN** buttons to select one of the 4 options:



- Off
- 575/750 W
- 1000 W
- 2000 W

02) Press the **SET** button to confirm the selection.

Note:

If you select Tungsten simulation, the device will use custom parameters for dimmer curve and dimmer speed. You can adjust the dimmer curve and the dimmer speed if Tungsten simulation is not selected (Off).

6.6.8. LED Mode

In this menu you can set the LED performance mode.

01) Press the **UP/DOWN** buttons to select one of the 2 options:

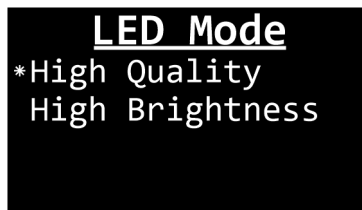

- High Quality: The device reaches a CRI between 96 and 97,7 at 3000 K
- High Brightness: The CRI is reduced to 93 and depending on the color temperature, the intensity of the light output increases with 20–30 %

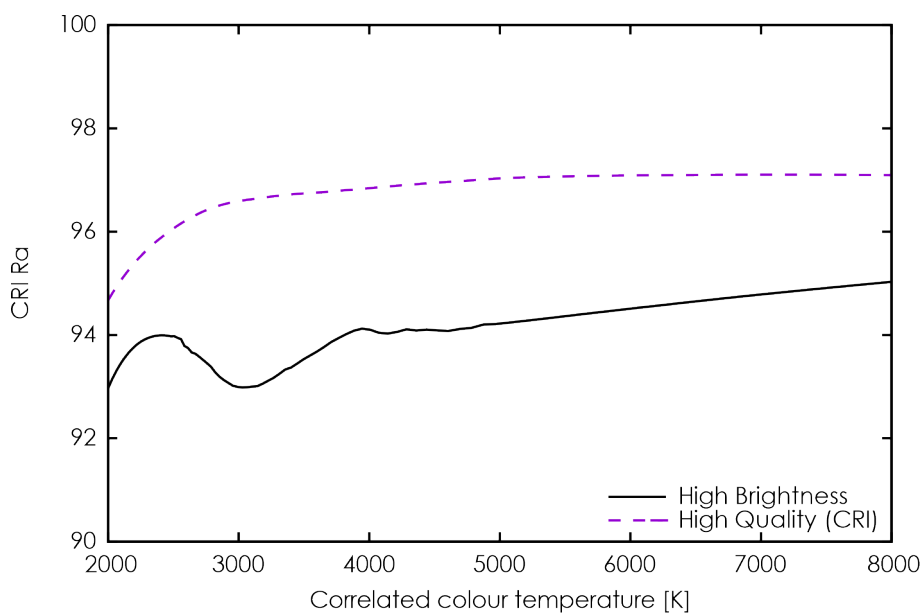

Figure 16

02) Press the **SET** button to confirm the selection.

6.6.9. Calibration

In this menu you can enable the built-in calibration. The built-in calibration guarantees that the color rendering, the color temperature and the brightness of the LEDs remain the same despite differences in the temperature of the LEDs or between different production runs of the same device.

- 01) Press the **UP/DOWN** buttons to choose one of the 2 options:
- Off: The built-in calibration is disabled
 - On: The built-in calibration is enabled. It is recommended to use this setting
- 02) Press the **SET** button to confirm.

6.6.10. LED Frequency

In this menu you can adjust the PWM (pulse-width modulation) frequency of the LEDs.

- 01) Press the **UP/DOWN** buttons to select one of the 6 options:
- 640 Hz
 - 1280 Hz
 - 2500 Hz
 - 5 kHz
 - 10 kHz
 - 25 kHz
- 02) Press the **SET** button to confirm the selection.

6.6.11. Display

In this menu you can adjust the display settings of the device.

- 01) Press the **UP/DOWN** buttons to select one of the 3 options:



- Backlight (see [6.6.11.1. Backlight](#))
 - Display Flip (see [6.6.11.2. Display Flip](#))
 - Key Lock (see [6.6.11.3. Key Lock](#))
- 02) Press the **SET** button to open the selected submenu.

6.6.11.1. Backlight

In this submenu you can adjust the behavior of the display.

- 01) Press the **UP/DOWN** buttons to select one of the 3 options:
- Auto: The display returns to the start screen after 20 s of inactivity. After 5 s more the backlight of the display turns off. If the DMX signal is lost, the display starts blinking
 - Stay On: The display does not return to the start screen and the backlight remains on
 - Stay Off: The display returns to the start screen after 20 s of inactivity. After 5 s more the backlight of the display turns off and remains off
- 02) Press the **SET** button to confirm the selection.

6.6.11.2. Display Flip

In this submenu you can rotate the display by 180°.

- 01) Press the **UP/DOWN** buttons to select one of the 2 options:
- Regular: Regular view
 - Top Down: The display is rotated by 180°
- 02) Press the **SET** button to confirm the selection.

6.6.11.3.Key Lock

In this submenu you can activate the display lock.

01) Press the **UP/DOWN** buttons to select one of the 2 options:

- Locked: The display lock is on. Do not press any button within 10 s of activating the lock. If you do so, the lock will be canceled. The selection remains but the display is not locked
- Unlocked: The access to the main menu remains unlocked

02) Press the **SET** button to confirm the selection.

Note:

If the display is locked, you need to enter a password to access the main menu. The default password is pressing the **UP/DOWN** buttons in the following order: **UP, DOWN, UP, DOWN**.

6.6.12. DMX Lost

In this menu you can determine the behavior of the device in case there is no DMX signal.

01) Press the **UP/DOWN** buttons to select one of the 3 options:

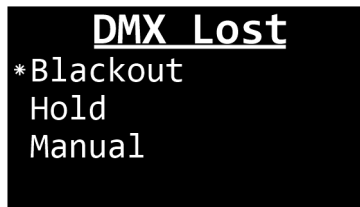

- Blackout: The device will black out the light output
- Hold: The device will use the last DMX signal correctly received
- Manual: The device will use the values selected in Manual Mode (see [6.6.3. Manual Mode](#) on page 26)

02) Press the **SET** button to confirm the selection.

6.6.13. Information

In this menu you can view the parameters of the device.

01) Press the **UP/DOWN** buttons to select one of the 9 options:

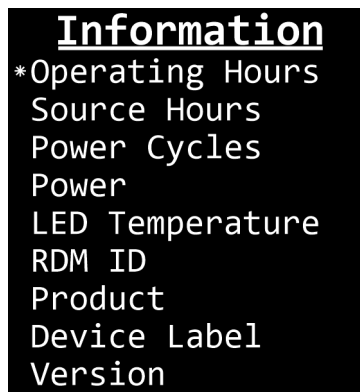

- Operating Hours: Shows the total hours of operation of the device
- Source Hours: Shows the total hours of operation of the LEDs
- Power Cycles: Provides information about how many times the device was powered up
- Power: Shows the real-time power consumption (see [6.6.13.1. Power Consumption](#)) of the device
- LED Temperature: Provides information about the temperature of the LEDs
- RDM ID: Shows the RDM identification number of the device (29B4:0A9XXXXX)
- Product: Shows the name of the device
- Device Label: Shows the RDM device label of the device
- Version: Shows the current firmware version and hash code

02) Press the **SET** button to open each submenu and view the parameters.

6.6.13.1. Power Consumption

To see the real-time power consumption of the device, follow the steps below:

- 01) Turn on the Dimmer in Static Color mode (see [6.6.3.1. Static Color Mode](#) on page 26).
- 02) Do not press any button and wait 20 s until the display turns off.
- 03) Navigate to the Main Menu. The light output should still be on.
- 04) Open the Power submenu to view the real-time power consumption of the device.

Note:

If you open the Power submenu before the display turns off, you cannot view the real-time power consumption. If you exit the Manual menu via the control panel, the light output turns off and the display reads "0 W".

6.6.14. Send Settings

In this menu you can send the current settings of the device to other connected Raccoon devices.

- 01) Press the **UP/DOWN** buttons to select one of the 3 options:



- Abort: Cancel the transfer of data and return to the previous screen
- Without DMX Addr: Send all settings, excluding the DMX starting address
- With DMX Address: Send all settings, including the DMX starting address

- 02) Press the **SET** button to confirm the selection. If you have selected to send the settings, the display shows a confirmation message that the settings are transferred

6.6.15. Factory Settings

In this menu you can reset the settings of the device to the default factory settings.

- 01) Press the **UP/DOWN** buttons to choose between:



- Abort: Cancel the reset and return to the previous screen
- Reset Settings: Reset all settings

- 02) Press the **SET** button to confirm your choice. If you have selected Reset Settings, the display shows a confirmation message that the defaults are restored.

6.7. DMX Channels

6.7.1. DMX Channels Overview

Function	Dimmer 1 CH	Pixel 3 CH	Basic 8 CH	XY 8 CH	RGB 12 CH	CMY 12 CH	HSI 10 CH	HSI+CCT 12 CH	CMY+CCT 15 CH	RGB+CCT 15 CH	Raw 14 CH
Dimmer Coarse	1		1	1	1	1	1	1	1	1	
Dimmer Fine			2	2	2	2	2	2	2	2	
Strobe			3	3	3	3	3	3	3	3	
Hue Coarse							4	6			
Hue Fine							5	7			
Saturation							6	8			
Intensity							7	9			
CCT			4					4	4	4	
Tint			5					5	5	5	
Red Coarse		1			4					6	1
Red Fine					5					7	2
Green Coarse		2			6					8	3
Green Fine					7					9	4
Blue Coarse		3			8					10	5
Blue Fine					9					11	6
Lime Coarse											7
Lime Fine											8
Amber Coarse											9
Amber Fine											10
Cyan Coarse						4			6		11
Cyan Fine						5			7		12
Magenta Coarse						6			8		
Magenta Fine						7			9		
Yellow Coarse						8			10		
Yellow Fine						9			11		
Royal Blue Coarse											13
Royal Blue Fine											14
X Coarse				4							
X Fine				5							
Y Coarse				6							
Y Fine				7							
Color Crossfade									12	12	
Color Presets			6		10	10	8	10	13	13	
Color Saturation			7		11	11	9	11	14	14	
Control			8	8	12	12	10	12	15	15	

6.7.2. Dimmer (1 Channel), Pixel (3 Channels), XY (8 Channels), Raw (14 Channels)

Dimmer 1 CH	Pixel 3 CH	XY 8 CH	Raw 14 CH	Function	Value	Setting
1		1		Dimmer Coarse	000–255	From low to high intensity (0–100 %)
				Dimmer Fine	000–255	From low to high intensity (0–100 %), 16-bit
		3		Strobe	000–005	Closed (No light output)
					006–125	Strobe, from low to high frequency
					126–129	Open
					130–249	Random strobe, from low to high frequency
					250–255	Open
1		1	Red Coarse	000–255	From low to high intensity (0–100 %)	
			Red Fine	000–255	From low to high intensity (0–100 %), 16-bit	
2		3	Green Coarse	000–255	From low to high intensity (0–100 %)	
			Green Fine	000–255	From low to high intensity (0–100 %), 16-bit	
3		4	Blue Coarse	000–255	From low to high intensity (0–100 %)	
			Blue Fine	000–255	From low to high intensity (0–100 %), 16-bit	
			Lime Coarse	000–255	From low to high intensity (0–100 %)	
			Lime Fine	000–255	From low to high intensity (0–100 %), 16-bit	
			Amber Coarse	000–255	From low to high intensity (0–100 %)	
			Amber Fine	000–255	From low to high intensity (0–100 %), 16-bit	
			Cyan Coarse	000–255	From low to high intensity (0–100 %)	
Cyan Fine	000–255	From low to high intensity (0–100 %), 16-bit				
		5	Royal Blue Coarse	000–255	From low to high intensity (0–100 %)	
			Royal Blue Fine	000–255	From low to high intensity (0–100 %), 16-bit	
		6	X Coarse	000–255	0–100 %	
			X Fine	000–255	0–100 %, 16-bit	
		7	Y Coarse	000–255	0–100 %	
			Y Fine	000–255	0–100 %, 16-bit	
		8	Control		000–007	No function
					008–015	Dimmer curve: Linear
					016–023	Dimmer curve: S-Curve
					024–031	Dimmer curve: Square Law
					032–039	Dimmer curve: Inverse Sq. Law
					040–047	Dimmer speed: Auto
					048–053	Dimmer speed: Slow
					054–059	Dimmer speed: Medium
					060–065	Dimmer speed: Fast
					066–071	Simulation source: Tungsten off
					072–079	Simulation source: Tungsten 575 W
					080–087	Simulation source: Tungsten 750 W
					088–095	Simulation source: Tungsten 1000 W
					096–103	Simulation source: Tungsten 2000 W
					104–111	PWM frequency: 640 Hz
					112–119	PWM frequency: 1280 Hz
					120–127	PWM frequency: 2500 Hz
					128–135	PWM frequency: 5 kHz
					136–143	PWM frequency: 10 kHz
					144–151	PWM frequency: 25 kHz
	152–159	Calibration: disabled				
	160–167	Calibration: enabled				

Dimmer 1 CH	Pixel 3 CH	XY 8 CH	Raw 14 CH	Function	Value	Setting
					168–175	Reserved
					176–183	Reserved
					184–191	Reserved
					192–199	Graphic display: Auto Off
					200–207	Graphic display: On
					208–215	CCT mode: High CRI
					216–223	CCT mode: High Output
					224–230	Color space: Native
					231–237	Color space: sRGB
					238–243	Color space: Rec. 2020
					244–250	Color space: ProPhoto RGB
					251–255	Reset all control channel settings

6.7.3. Basic (8 Channels), RGB (12 Channels), CMY (12 Channels), HSI (10 Channels)

Basic 8 CH	RGB 12 CH	CMY 12 CH	HSI 10 CH	Function	Value	Setting
1	1	1	1	Dimmer Coarse	000–255	From low to high intensity (0–100 %)
2	2	2	2	Dimmer Fine	000–255	From low to high intensity (0–100 %), 16-bit
3	3	3	3	Strobe	000–005	Closed (No light output)
					006–125	Strobe, from low to high frequency
					126–129	Open
					130–249	Random strobe, from low to high frequency
					250–255	Open
4				CCT	000–000	2000 K
					000–031	2000–2200 K
					031–031	2200 K
					031–057	2200–2400 K
					057–057	2400 K
					057–078	2400–2600 K
					078–078	2600 K
					079–097	2600–2800 K
					097–097	2800 K
					097–113	2800–3000 K
					113–113	3000 K
					113–127	3000–3200 K
					128–128	3200 K
					128–146	3200–3500 K
					146–146	3500 K
					146–170	3500–4000 K
					170–170	4000 K
					170–189	4000–4500 K
					189–189	4500 K
					189–204	4500–5000 K
					204–204	5000 K
204–216	5000–5500 K					
216–216	5500 K					
216–227	5500–6000 K					
227–227	6000 K					
227–235	6000–6500 K					
235–235	6500 K					
235–243	6500–7000 K					
243–243	7000 K					
243–249	7000–7500 K					
249–249	7500 K					
249–255	7500–8000 K					
255–255	8000 K					
5				Tint	000–255	From -100 % to 100 %
	4			Red Coarse	000–255	From low to high intensity (0–100 %)
	5			Red Fine	000–255	From low to high intensity (0–100 %), 16-bit

Basic 8 CH	RGB 12 CH	CMY 12 CH	HSI 10 CH	Function	Value	Setting
	6			Green Coarse	000–255	From low to high intensity (0–100 %)
	7			Green Fine	000–255	From low to high intensity (0–100 %), 16-bit
	8			Blue Coarse	000–255	From low to high intensity (0–100 %)
	9			Blue Fine	000–255	From low to high intensity (0–100 %), 16-bit
		4		Cyan Coarse	000–255	From low to high intensity (0–100 %)
		5		Cyan Fine	000–255	From low to high intensity (0–100 %), 16-bit
		6		Magenta Coarse	000–255	From low to high intensity (0–100 %)
		7		Magenta Fine	000–255	From low to high intensity (0–100 %), 16-bit
		8		Yellow Coarse	000–255	From low to high intensity (0–100 %)
		9		Yellow Fine	000–255	From low to high intensity (0–100 %), 16-bit
6	10	10	8	Color Presets	000–255	Color presets (see 6.7.5. Lee Color Presets on page 40)
7	11	11	9	Color Saturation	000–255	Saturation of color filter (100–0 %)
					000–007	No function
					008–015	Dimmer curve: Linear
					016–023	Dimmer curve: S-Curve
					024–031	Dimmer curve: Square Law
					032–039	Dimmer curve: Inverse Sq. Law
					040–047	Dimmer speed: Auto
					048–053	Dimmer speed: Slow
					054–059	Dimmer speed: Medium
					060–065	Dimmer speed: Fast
					066–071	Simulation source: Tungsten off
					072–079	Simulation source: Tungsten 575 W
					080–087	Simulation source: Tungsten 750 W
					088–095	Simulation source: Tungsten 1000 W
					096–103	Simulation source: Tungsten 2000 W
					104–111	PWM frequency: 640 Hz
					112–119	PWM frequency: 1280 Hz
					120–127	PWM frequency: 2500 Hz
					128–135	PWM frequency: 5 kHz
					136–143	PWM frequency: 10 kHz
					144–151	PWM frequency: 25 kHz
					152–159	Calibration: disabled
					160–167	Calibration: enabled
					168–175	Reserved
					176–183	Reserved
					184–191	Reserved
					192–199	Graphic display: Auto Off
					200–207	Graphic display: On
					208–215	CCT mode: High CRI
					216–223	CCT mode: High Output
					224–230	Color space: Native
					231–237	Color space: sRGB
					238–243	Color space: Rec. 2020
					244–250	Color space: ProPhoto RGB
					251–255	Reset all control channel settings
8	12	12	10	Control		







6.7.4. HSI+CCT (12 Channels), CMY+CCT (15 Channels), RGB+CCT (15 Channels)

HSI+CCT 12 CH	CMY+CCT 15 CH	RGB+CCT 15 CH	Function	Value	Setting
1	1	1	Dimmer Coarse	000–255	From low to high intensity (0–100 %)
2	2	2	Dimmer Fine	000–255	From low to high intensity (0–100 %), 16-bit
3	3	3	Strobe	000–005	Closed (No light output)
				006–125	Strobe, from low to high frequency
				126–129	Open
				130–249	Random strobe, from low to high frequency
				250–255	Open
4	4	4	CCT	000–000	2000 K
				000–031	2000–2200 K
				031–031	2200 K
				031–057	2200–2400 K
				057–057	2400 K
				057–078	2400–2600 K
				078–078	2600 K
				079–097	2600–2800 K
				097–097	2800 K
				097–113	2800–3000 K
				113–113	3000 K
				113–127	3000–3200 K
				128–128	3200 K
				128–146	3200–3500 K
				146–146	3500 K
				146–170	3500–4000 K
				170–170	4000 K
				170–189	4000–4500 K
				189–189	4500 K
				189–204	4500–5000 K
				204–204	5000 K
				204–216	5000–5500 K
				216–216	5500 K
				216–227	5500–6000 K
				227–227	6000 K
227–235	6000–6500 K				
235–235	6500 K				
235–243	6500–7000 K				
243–243	7000 K				
243–249	7000–7500 K				
249–249	7500 K				
249–255	7500–8000 K				
255–255	8000 K				
5	5	5	Tint	000–255	From -100 % to 100 %
6			Hue Coarse	000–255	From low to high hue intensity (0–100 %)
7			Hue Fine	000–255	From low to high hue intensity (0–100 %), 16-bit
8			Saturation	000–255	From low to high saturation (0–100 %)
9			Intensity	000–255	From low to high intensity (0–100 %)
		6	Red Coarse	000–255	From low to high intensity (0–100 %)
		7	Red Fine	000–255	From low to high intensity (0–100 %), 16-bit

HSI+CCT 12 CH	CMY+CCT 15 CH	RGB+CCT 15 CH	Function	Value	Setting
		8	Green Coarse	000–255	From low to high intensity (0–100 %)
		9	Green Fine	000–255	From low to high intensity (0–100 %), 16-bit
		10	Blue Coarse	000–255	From low to high intensity (0–100 %)
		11	Blue Fine	000–255	From low to high intensity (0–100 %), 16-bit
	6		Cyan Coarse	000–255	From low to high intensity (0–100 %)
	7		Cyan Fine	000–255	From low to high intensity (0–100 %), 16-bit
	8		Magenta Coarse	000–255	From low to high intensity (0–100 %)
	9		Magenta Fine	000–255	From low to high intensity (0–100 %), 16-bit
	10		Yellow Coarse	000–255	From low to high intensity (0–100 %)
	11		Yellow Fine	000–255	From low to high intensity (0–100 %), 16-bit
	12	12	Color Crossfade	000–255	Crossfade from Color to CCT
10	13	13	Color Presets	000–255	Color presets (see 6.7.5. Lee Color Presets on page 40)
11	14	14	Color Saturation	000–255	Saturation of color filter (100–0 %)
12	15	15	Control	000–007	No function
				008–015	Dimmer curve: Linear
				016–023	Dimmer curve: S-Curve
				024–031	Dimmer curve: Square Law
				032–039	Dimmer curve: Inverse Sq. Law
				040–047	Dimmer speed: Auto
				048–053	Dimmer speed: Slow
				054–059	Dimmer speed: Medium
				060–065	Dimmer speed: Fast
				066–071	Simulation source: Tungsten off
				072–079	Simulation source: Tungsten 575 W
				080–087	Simulation source: Tungsten 750 W
				088–095	Simulation source: Tungsten 1000 W
				096–103	Simulation source: Tungsten 2000 W
				104–111	PWM frequency: 640 Hz
				112–119	PWM frequency: 1280 Hz
				120–127	PWM frequency: 2500 Hz
				128–135	PWM frequency: 5 kHz
				136–143	PWM frequency: 10 kHz
				144–151	PWM frequency: 25 kHz
				152–159	Calibration: disabled
				160–167	Calibration: enabled
				168–175	Reserved
				176–183	Reserved
				184–191	Reserved
192–199	Graphic display: Auto Off				
200–207	Graphic display: On				
208–215	CCT mode: High CRI				
216–223	CCT mode: High Output				
224–230	Color space: Native				
231–237	Color space: sRGB				
238–243	Color space: Rec. 2020				
244–250	Color space: ProPhoto RGB				
251–255	Reset all control channel settings				

6.7.5. Lee Color Presets

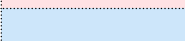
Value	Preset Color	Number	Color
000–007	Open		
008–010	Medium Bastard Amber	L004	
011–013	Fire	L019	
014–016	Bright Red	L026	
017–019	Lavender	L058	
020–022	Sky Blue	L068	
023–025	Just Blue	L079	
026–028	Lime Green	L088	
029–031	Dark Yellow Green	L090	
032–034	Spring Yellow	L100	
035–037	Yellow	L101	
038–040	Light Amber	L102	
041–043	Straw	L103	
044–046	Deep Amber	L104	
047–049	Orange	L105	
050–052	Primary Red	L106	
053–055	Dark Pink	L111	
056–058	Magenta	L113	
059–061	Peacock Blue	L115	
062–064	Medium Blue Green	L116	
065–067	Steel Blue	L117	
068–070	Light Blue	L118	
071–073	Dark Blue	L119	
074–076	Deep Blue	L120	
077–079	Lee Green	L121	
080–082	Fern Green	L122	
083–085	Dark Green	L124	
086–088	Bright Pink	L128	
089–091	Medium Blue	L132	
092–094	Golden Amber	L134	
095–097	Deep Golden Amber	L135	
098–100	Pale Lavender	L136	
101–103	Special Lavender	L137	
104–106	Pale Green	L138	
107–109	Primary Green	L139	
110–112	Bright Blue	L141	
113–115	Apricot	L147	
116–118	Bright Rose	L148	
119–121	Pale Gold	L152	
122–124	Pink	L157	
125–127	Deep Orange	L158	
128–130	Bastard Amber	L162	
131–133	Flame Red	L164	
134–136	Daylight Blue	L165	

Value	Preset Color	Number	Color
137-139	Lilac Tint	L169	
140-142	Deep Lavender	L170	
143-145	Lagoon Blue	L172	
146-148	Chrome Orange	L179	
149-151	Dark Lavender	L180	
152-154	Congo Blue	L181	
155-157	Alice Blue	L197	
158-160	Full CT Blue	L201	
161-163	Half CT Blue	L202	
164-166	Quarter CT Blue	L203	
167-169	Full CT Orange	L204	
170-172	Half CT Orange	L205	
173-175	Quarter CT Orange	L206	
176-178	LEE Minus Green	L247	
179-181	Half Minus Green	L248	
182-184	Three Quarter CT Blue	L281	
185-187	Three Quarter CT Orange	L285	
188-190	Follies Pink	L328	
191-193	Lighter Blue	L353	
194-196	Millennium Gold	L778	
197-199	Vanity Fair	L793	
200-255	Reserved		

6.8. RDM Information

This device supports RDM (see [6.8.2. Supported RDM PIDs \(Parameter IDs\)](#)).

6.8.1. RDM Details

- Responder: 29B4:0A9XXXXX
- Manufacturer's ID: Infinity (Highlite International B.V.)
- Manufacturer Label: Infinity
- Model Description: Raccoon P7/7
- Model ID: 169 (A9 hexadecimal)
- Device Label: Raccoon P7/7

Note:

An RDM responder ID consists of 3 parts:

- 1st part – 4 digits – Manufacturer's ID
- 2nd part – 3 digits – Model ID
- 3rd part – 5 digits – Unique ID

The RDM responder IDs of all products of Highlite International start with the same 4 digits. The first 7 digits of the RDM responder ID for each model are the same. The last 5 digits are different for each device.

6.8.2. Supported RDM PIDs (Parameter IDs)

Parameter ID	Value	Required	GET	SET
SUPPORTED_PARAMETERS	0x0050	*	*	
DEVICE_MODEL_DESCRIPTION	0x0080		*	
MANUFACTURER_LABEL	0x0081		*	
DEVICE_LABEL	0x0082		*	*
FACTORY_DEFAULTS	0x0090		*	*
BOOT_SOFTWARE_VERSION_ID	0x00C1		*	
BOOT_SOFTWARE_VERSION_LABEL	0x00C2		*	
DMX_PERSONALITY	0x00E0		*	*
DMX_PERSONALITY_DESCRIPTION	0x00E1		*	
DMX_START_ADDRESS	0x00F0	*	*	*
SENSOR_DEFINITION	0x0200		*	
SENSOR_VALUE	0x0201		*	*
RECORD_SENSORS	0x0202			*
DEVICE_HOURS	0x0400		*	*
LAMP_HOURS	0x0401		*	*
LAMP_STRIKES	0x0402		*	*
DEVICE_POWER_CYCLES	0x0405		*	*
RESET_DEVICE	0x1001			*

7. Troubleshooting

This troubleshooting guide contains solutions to problems which can be carried out by an ordinary person. The device does not contain user-serviceable parts.

Unauthorized modifications to the device will render the warranty void. Such modifications may result in injuries and material damage.

Refer servicing to instructed or skilled persons. Contact your Highlite International dealer in case the solution is not described in the table.

Problem	Probable cause(s)	Solution
The device does not function at all	No power to the device	<ul style="list-style-type: none"> Make sure that the device is connected to the power supply and the cables are plugged in
	The internal fuse is blown	<ul style="list-style-type: none"> Disconnect the device and contact your Highlite International dealer
The device responds erratically	The factory settings of the device are changed	<ul style="list-style-type: none"> Reset the parameters of the device to the default factory settings (see 6.6.15. Factory Settings on page 32)
The device does not respond to DMX control	The controller is not connected	<ul style="list-style-type: none"> Connect the controller
	The signal is reversed. The 5-pin DMX OUT of the controller does not match the DMX IN of the device	<ul style="list-style-type: none"> Install a phase-reversing cable between the controller and the device
	The controller is defective	<ul style="list-style-type: none"> Try using another controller
The device responds erratically to DMX control	Connections are defective	<ul style="list-style-type: none"> Examine connections and cables. Correct defective connections. Repair or replace damaged cables
	The data link is not terminated with a 120 Ω termination plug	<ul style="list-style-type: none"> Insert a termination plug in the DMX OUT connector of the last device on the link
	Incorrect addressing	<ul style="list-style-type: none"> Make sure that the address settings are correct
	In case of a setup with multiple devices, one of the devices is defective and disturbs data transmission on the link	<ul style="list-style-type: none"> To find the defective device, bypass one device at a time until normal operation is restored
No light or LEDs cut out intermittently	LEDs are damaged	<ul style="list-style-type: none"> Disconnect the device and contact your Highlite International dealer
	The input power parameters of the device do not match local AC voltage and frequency	<ul style="list-style-type: none"> Disconnect the device. Make sure that the local current, voltage and frequency match the input voltage, current and frequency specified on the information label on the device

8. Maintenance

8.1. Safety Instructions for Maintenance



DANGER
Electric shock caused by dangerous voltage inside

Disconnect power supply before servicing or cleaning.

8.2. Preventive Maintenance



Attention
Before each use, examine the device visually for any defects.

Make sure that:

- All screws used for installing the device or parts of the device are tightly fastened and are not corroded.
- The safety devices are not damaged.
- There are no deformations on housings, fixings and installation points.
- The lens is not cracked or damaged.
- The power cables are not damaged and do not show any material fatigue.

8.2.1. Basic Cleaning Instructions

The external lens of the device must be cleaned periodically in order to optimize the light output. The cleaning schedule depends on the conditions at the site where the device is installed. When smoke or fog machines are used at the site, the device will need more frequent cleaning. On the other hand, if the device is installed in well-ventilated area, it will need less frequent cleaning. To establish a cleaning schedule, examine the device at regular intervals during the first 100 hours of operation.

To clean the device, follow the steps below:

- 01) Disconnect the device from the electrical power supply.
- 02) Allow the device to cool down for at least 15 minutes.
- 03) Remove the dust collected on the external surface with dry compressed air and a soft brush.
- 04) Clean the lens with a damp cloth. Use a mild detergent solution.
- 05) Dry the lens carefully with a lint-free cloth.
- 06) Clean the DMX and other connections with a damp cloth.



Attention

- Do not immerse the device in liquid.
- Do not use alcohol or solvents.
- Make sure that the connections are fully dry before connecting the device to the power supply and to other devices.

8.3. Corrective Maintenance

The device does not contain user-serviceable parts. Do not open the device and do not modify the device.

Refer repairs and servicing to instructed or skilled persons. Contact your Highlite International dealer for more information.

9. Deinstallation, Transportation and Storage

9.1. Instructions for Deinstallation



WARNING

Incorrect deinstallation can cause serious injuries and damage of property.

- Let the device cool down before dismantling.
- Disconnect power supply before deinstallation.
- Always observe the national and site-specific regulations during deinstallation and derigging of the device.
- Wear personal protective equipment in compliance with the national and site-specific regulations.

9.2. Instructions for Transportation

- Use the original packaging to transport the device, if possible.
- Always observe the handling instructions printed on the outer carton box, for example: "Handle with care", "This side up", "Fragile".

9.3. Storage

- Clean the device before storing (see [8.2.1. Basic Cleaning Instructions](#) on page 44).
- Store the device in the original packaging, if possible.

10. Disposal

Correct disposal of this product

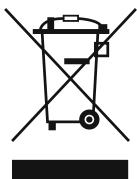

Waste Electrical and Electronic Equipment

This symbol on the product, its packaging or documents indicates that the product shall not be treated as household waste. Dispose of this product by handing it to the respective collection point for recycling of electrical and electronic equipment. This is to avoid environmental damage or personal injury due to uncontrolled waste disposal. For more detailed information about recycling of this product contact the local authorities or the authorized dealer.

11. Approval



Check the respective product page on the website of Highlite International (www.highlite.com) for an available declaration of conformity.

12. Changelog

Version	Release Date	Description
V1.0	August 2024	First release of the user manual
V2.0	September 2025	Firmware update. V2.04/9933 has 3 extra DMX personalities: HSI+CCT (12 channels), CMY+CCT (15 channels), RGB+CCT (15 channels)

